



Swivel Joint - Type DG-01

DN 20 - DN 100



Swivel Joint

Structure

- stator (outer part) and rotor (inner part) joined by a single-row ball bearing
- for-life lubrication provided in the factory
- welded connection parts: welding ends, pipe bends or flanges

Materials

basic unit	welding end	flange
1.7225	1.0305	1.0460
1.4571	1.4571	1.4571

Standard sealings

- PTFE compound sealings

Special sealings

- additional inner sealing for heavily polluted media
- medium sealings for oxygen, steam and food products

Pressure rating

- PN 16 (1.7225) with flanges
- PN 100 (1.7225) with welding ends
- PN 16 (1.4571) with flanges
- PN 40 (1.4571) with welding ends

Surface protection

- Gas nitration
- Corrosion-protection primer

Design

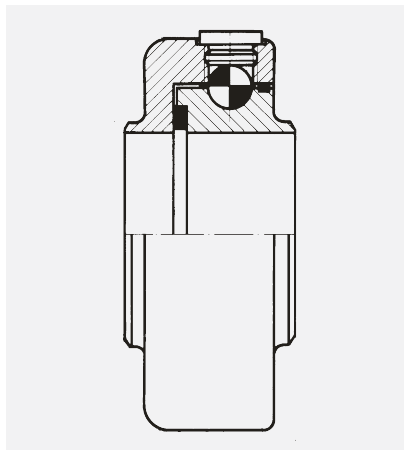

Type DG-01 basic unit with single-row ball bearing

Dimensions

Standard: DN 20 to DN 100
 Flanges: PN 16 to EN 1092
 Others: possible to ANSI (ASA), BS etc.
 Welding end: to ISO recommendations

Notes

General technical instructions must be observed. Subject to technical alterations and fluctuations caused by the production process. Number of revolutions for swivel and rotation movements ≤ 10 rpm. Swivel movements in several planes see catalogue page 5/5. Sets of sealings and balls available individually as spare parts.

Application

- for liquid or gaseous media at high temperatures and pressures
- for slow swivel and rotation movements through 360°
- for rough operating conditions
 - in hydraulic flow pipes
 - at roll stands
 - in sewage plant
 - in steel mills
 - at hose drums
- for installation in flexible pipeline systems, for conveying media from a fixed point to any required flexible point
 - filling systems
 - loading and swivel arms
 - pipe joint shears
- use at test facilities
- special designs suitable for food products



STENFLEX® Swivel Joint type DG-01 installed in a pump test facility



Form 11 F / flange connection*

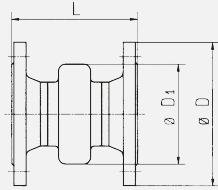

DN	ø D1 mm	1.7225/1.4571/PN 16	
		ø D mm	L mm
20	72	105	139
25	78	115	144
32	88	140	148
40	96	150	154
50	118	165	164
65	133	185	169
80	139	200	179
100	164	220	183

Form 11 S / welding ends

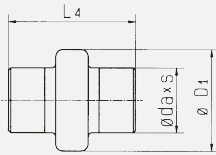

DN	ø D1 mm	1.7225/PN 100			1.4571/PN 40		
		ø da mm	s mm	L ₄ mm	ø da mm	s mm	L ₄ mm
20	72	26.9	2.9	159	26.9	2.9	159
25	78	33.7	3.4	164	33.7	3.4	164
32	88	42.4	3.6	164	42.4	3.6	164
40	96	48.3	3.7	164	48.3	3.7	164
50	118	60.3	3.9	174	60.3	3.9	174
65	133	73.0	5.2	179	73.0	5.2	179
80	139	88.9	5.5	179	88.9	5.5	179
100	164	114.3	6.0	179	114.3	6.0	179

Form 12 F / flange connection*

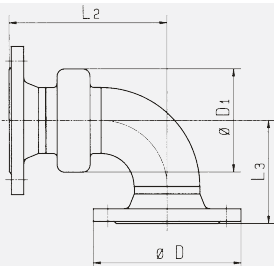

DN	ø D1 mm	1.7225/PN 16			1.4571/PN 16		
		ø D mm	L ₂ mm	L ₃ mm	ø D mm	L ₂ mm	L ₃ mm
20	72	105	124	67	105	137	80
25	78	115	129	67	115	142	80
32	88	140	138	76	140	154	92
40	96	150	147	85	150	166	104
50	118	165	170	98	165	195	123
65	133	185	187	110	185	219	142
80	139	200	205	128	200	243	166
100	164	220	233	156	220	283	206

Form 12 S / welding ends

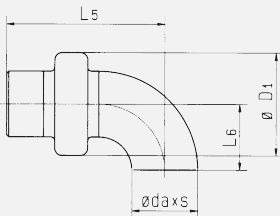

DN	ø D1 mm	1.7225/PN 100				1.4571/PN 40			
		ø da mm	s mm	L ₅ mm	L ₆ mm	ø da mm	s mm	L ₅ mm	L ₆ mm
20	72	26.9	2.9	134	25	26.9	2.9	138	29
25	78	33.7	3.4	139	25	33.7	3.4	152	38
32	88	42.4	3.6	146	32	42.4	3.6	162	48
40	96	48.3	3.7	152	38	48.3	3.7	171	57
50	118	60.3	3.9	175	51	60.3	3.9	200	76
65	133	76.1	5.2	192	63	73.0	5.2	224	95
80	139	88.9	5.5	205	76	88.9	5.5	243	114
100	164	114.3	6.0	231	102	114.3	6.0	281	152

Form 13 F / flange connection*

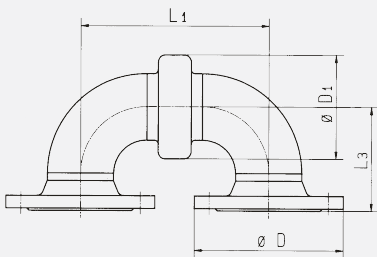

DN	ø D1 mm	1.7225/PN 16			1.4571/PN 16		
		ø D mm	L ₁ mm	L ₃ mm	ø D mm	L ₁ mm	L ₃ mm
20	72	105	109	67	105	135	80
25	78	115	114	67	115	140	80
32	88	140	128	76	140	160	92
40	96	150	140	85	150	178	104
50	118	165	176	98	165	226	123
65	133	185	205	110	185	269	142
80	139	200	231	128	200	307	166
100	164	220	283	156	220	383	206

Form 13 S / welding ends

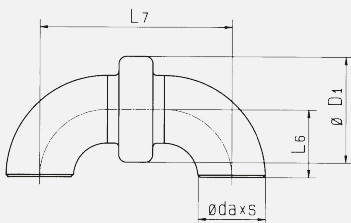

DN	ø D1 mm	1.7225/PN 100				1.4571/PN 40			
		ø da mm	s mm	L ₆ mm	L ₇ mm	ø da mm	s mm	L ₆ mm	L ₇ mm
20	72	26.9	2.9	25	109	26.9	2.9	29	117
25	78	33.7	3.4	25	114	33.7	3.4	38	140
32	88	42.4	3.6	32	128	42.4	3.6	48	160
40	96	48.3	3.7	38	140	48.3	3.7	57	178
50	118	60.3	3.9	51	176	60.3	3.9	76	226
65	133	76.1	5.2	63	205	73.0	5.2	95	269
80	139	88.9	5.5	76	231	88.9	5.5	114	307
100	164	114.3	6.0	102	283	114.3	6.0	152	383

*PN 40 flange connection possible on request. Materials data stated for basic units.