



## Swivel Joint - Type DG-02L

DN 125 - DN 700



### Swivel Joint

#### Structure

- stator (outer part) and rotor (inner part) joined by a two-row ball bearing
- for-life lubrication provided in the factory
- welded connection parts: welding ends, pipe bends or flanges

#### Materials

basic unit	welding end	flange
1.7225	1.0305	1.0460
1.4571	1.4571	1.4571

#### Standard sealings

- PTFE compound sealings

#### Special sealings

- additional inner sealing for heavily polluted media
- hermetic radial sealing for underwater applications (from DN 65)
- medium sealings for oxygen, steam and food products

#### Pressure rating

- PN 10, PN 16 (1.7225) with flanges
- PN 16, PN 40 (1.7225) with welding ends
- PN 10, PN 16 (1.4571) with flanges
- PN 6, PN 16 (1.4571) with welding ends

#### Surface protection

- Gas nitration
- Corrosion-protection primer

### Design

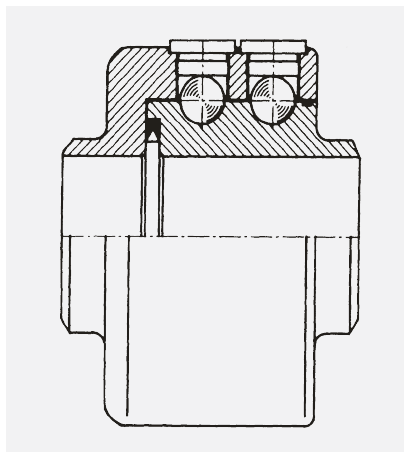

Type DG-02L basic unit with two-row ball bearing

### Dimensions

Standard: DN 125 to DN 700  
 Flanges: PN 10/16 to EN 1092  
 Others: possible to ANSI (ASA), BS etc.  
 Welding end: to ISO recommendations

### Notes

General technical instructions must be observed. Subject to technical alterations and fluctuations caused by the production process. Number of revolutions for swivel and rotation movements ≤ 10 rpm. Swivel movements in several planes see catalogue page 5/5. Sets of sealings and balls available individually as spare parts.

### Application

- for liquid or gaseous media at high temperatures and pressures
- for slow swivel and rotation movements through 360°
- for rough operating conditions
  - in hydraulic flow pipes
  - at roll stands
  - in sewage plant
  - in steel mills
  - at hose drums
- for installation in flexible pipeline systems, for conveying media from a fixed point to any required flexible point
  - filling systems
  - loading and swivel arms
  - pipe joint shears
- use at test facilities
- special designs suitable for food products



STENFLEX® Swivel Joint type DG-02L in cooling water line of exhaust pipe of furnace in a steel mill



## Form 11 F / flange connection\*

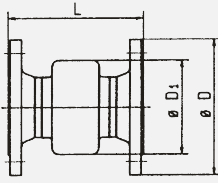

DN	ø D1 mm	1.7225				1.4571			
		PN 10		PN 16		PN 10		PN 16	
		ø D mm	L mm	ø D mm	L mm	ø D mm	L mm	ø D mm	L mm
125	197			250	241			250	241
150	223			285	251			285	251
200	277	340	263	340	263	340	265	340	263
250	325	395	277	405	281	395	277	405	281
300	390	445	282	460	302	445	282	460	302
350	420	505	282	520	310	505	282	520	310
400	470	565	290	580	316	565	290	580	316
500	590	670	296	715	326	670	296	715	326

## Form 11 S / welding ends

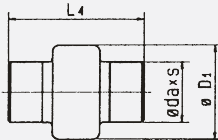

DN	ø D1 mm	ø d <sub>a</sub> mm	1.7225				1.4571			
			PN 16		PN 40		PN 6		PN 16	
			s mm	L <sub>1</sub> mm	s mm	L <sub>1</sub> mm	s mm	L <sub>1</sub> mm	s mm	L <sub>1</sub> mm
125	197	141.3	6.6	229	6.6	229	6.6	229	6.6	229
150	223	168.3	7.1	239	7.1	229	7.1	239	7.1	239
200	277	219.1	8.2	239	8.2	239	8.2	239	8.2	239
250	325	273.0	9.3	241	9.3	214	9.3	241	9.3	241
300	390	323.9	11.5	246	11.5	246	11.5	246	11.5	246
400	470	406.4	8.8	246			8.8	246		
500	590	508.0	9.5	246			9.5	246		

## Form 12 F / flange connection\*

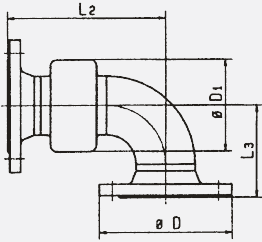

DN	ø D1 mm	1.7225						1.4571					
		PN 10			PN 16			PN 10			PN 16		
		ø D mm	L <sub>2</sub> mm	L <sub>3</sub> mm	ø D mm	L <sub>2</sub> mm	L <sub>3</sub> mm	ø D mm	L <sub>2</sub> mm	L <sub>3</sub> mm	ø D mm	L <sub>2</sub> mm	L <sub>3</sub> mm
125	197				250	311	184				250	374	247
150	223				285	346	209				285	423	286
200	277	340	404	267	340	404	267	340	506	369	340	506	369
250	325	395	463	325	405	465	327	395	590	454	405	592	454
300	390	445	519	376	460	529	386	445	671	538	460	681	538
350	420	505	570	427	520	584	441	505	747	618	520	761	618
400	470	565	624	481	580	637	494	565	828	698	580	841	698
500	590	670	729	586	715	744	601	670	983	855	715	998	855

## Form 12 S / welding ends

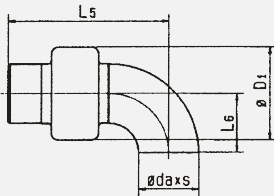

DN	ø D1 mm	ø d <sub>a</sub> mm	1.7225						1.4571					
			PN 16			PN 40			PN 6			PN 16		
			s mm	L <sub>5</sub> mm	L <sub>6</sub> mm	s mm	L <sub>5</sub> mm	L <sub>6</sub> mm	s mm	L <sub>5</sub> mm	L <sub>6</sub> mm	s mm	L <sub>5</sub> mm	L <sub>6</sub> mm
125	197	141.3	6.6	306	127	6.6	306	127	6.6	369	190	6.6	369	190
150	223	168.3	7.1	341	152	7.1	341	152	7.1	418	229	7.1	418	229
200	277	219.1	8.2	392	203	8.2	392	203	8.2	494	305	8.2	494	305
250	325	273.0	9.3	445	254	9.3	445	254	9.3	572	381	9.3	572	381
300	390	323.9	11.5	501	305	11.5	501	305	11.5	653	457	11.5	653	457
350	420	355.6	8.0	552	356				8.0	729	533			
400	470	406.4	8.8	602	406				8.8	806	610			
500	590	508.0	9.5	704	508				9.5	958	762			

## Form 13 F / flange connection\*

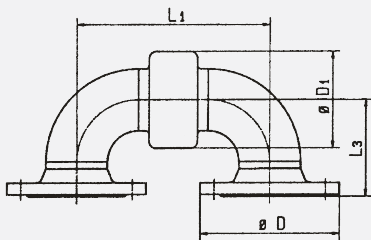

DN	ø D1 mm	1.7225						1.4571					
		PN 10			PN 16			PN 10			PN 16		
		ø D mm	L <sub>1</sub> mm	L <sub>3</sub> mm	ø D mm	L <sub>1</sub> mm	L <sub>3</sub> mm	ø D mm	L <sub>1</sub> mm	L <sub>3</sub> mm	ø D mm	L <sub>1</sub> mm	L <sub>3</sub> mm
125	197				250	383	184				250	509	247
150	223				285	443	209				285	597	286
200	277	340	545	267	340	545	267	340	749	369	340	749	369
250	325	395	649	325	405	649	327	395	903	454	405	903	454
300	390	445	756	376	460	756	386	445	1060	538	460	1060	538
350	420	505	858	427	520	858	441	505	1212	618	520	1212	618
400	470	565	958	481	580	958	494	565	1366	698	580	1366	698
500	590	670	1162	586	715	1162	601	670	1670	855	715	1670	855

## Form 13 S / welding ends

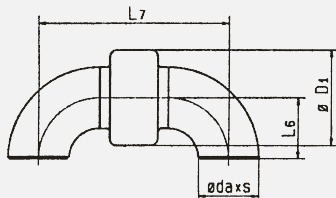

DN	ø D1 mm	ø d <sub>a</sub> mm	1.7225						1.4571					
			PN 16			PN 40			PN 6			PN 16		
			s mm	L <sub>7</sub> mm	L <sub>6</sub> mm	s mm	L <sub>7</sub> mm	L <sub>6</sub> mm	s mm	L <sub>7</sub> mm	L <sub>6</sub> mm	s mm	L <sub>7</sub> mm	L <sub>6</sub> mm
125	197	141.3	6.6	127	383	6.6	127	383	6.6	190	509	6.6	190	509
150	223	168.3	7.1	152	443	7.1	152	443	7.1	229	597	7.1	229	597
200	277	219.1	8.2	203	545	8.2	203	545	8.2	305	749	8.2	305	749
250	325	273.0	9.3	254	649	9.3	254	649	9.3	381	903	9.3	381	903
300	390	323.9	11.5	305	756	11.5	305	756	11.5	457	1060	11.5	457	1060
350	420	355.6	8.0	356	858				8.0	533	1212			
400	470	406.4	8.8	406	958				8.8	610	1366			
500	590	508.0	9.5	508	1162				9.5	762	1670			

\*PN 40 flange connection possible on request. Materials data stated for basic units.