

## Swivel Joint (rotating head joint) Type DK-01

DN 8 - DN 50



### Rotating head joint

#### Structure

- stator (outer part) and rotor (inner part) joined by a single-row ball bearing
- for-life lubrication provided in the factory
- female thread according to ISO 7-1 (DIN 2999)

#### Materials

Basic unit with threaded connection	
	1.7225
	1.4571

#### Standard sealings

- PTFE-Compounddichtung

#### Special sealings

- additional inner sealing for heavily polluted media
- medium sealings for oxygen, steam and food products

#### Pressure rating

- PN 100 (1.7225)
- PN 40 (1.4571)

#### Surface protection

- Gas nitration
- Corrosion-protection primer

### Design

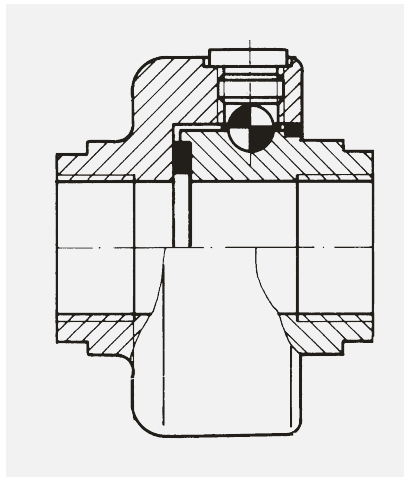

**Type DK-01**  
with one-row ball bearing

### Dimensions

DN 8 to DN 50

### Notes

General technical instructions must be observed. Subject to technical alterations and fluctuations caused by the production process.  
Number of revolutions for swivel and rotation movements  $\leq 10$  rpm.  
Swivel movements in several planes see catalogue page 5/5.  
Sets of sealings and balls available individually as spare parts.

### Application

- for liquid or gaseous media at high temperatures and pressures
- for slow swivel and rotation movements through 360°
- fast installation with threaded connection
- for rough operating conditions
  - in hydraulic flow pipes
  - at roll stands
  - at hose drums
- for installation in flexible pipeline systems, for conveying media from a fixed point to any required flexible point
  - filling systems
  - loading and swivel arms
  - pipe joint shears
- use at test facilities
- special designs suitable for food products



## Form 11IG / threaded connection

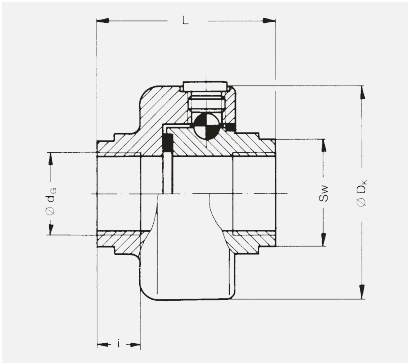

DN	$\varnothing d_G$ Zoll	i mm	$\varnothing D_k$ mm	$S_w$ mm	L mm	weight approx. kg
8	Rp 1/4"	12	72	32	78	1.2
10	Rp 3/8"	12	72	32	78	1.2
15	Rp 1/2"	14	72	32	78	1.3
20	Rp 3/4"	16	72	32	78	1.3
25	Rp 1"	18	78	41	85	1.6
32	Rp 1 1/4"	20	88	55	85	2.2
40	Rp 1 1/2"	22	96	60	90	2.2
50	Rp 2"	24	118	70	100	4.1

## Form 12IG / threaded connection

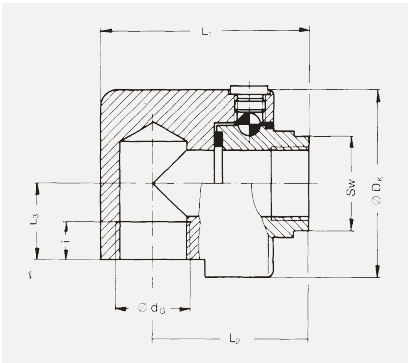

DN	$\varnothing d_G$ Zoll	i mm	$\varnothing D_k$ mm	$S_w$ mm	$L_1$ mm	$L_2$ mm	$L_3$ mm	weight approx. kg
8	Rp 1/4"	12	72	32	92	75	30	1.8
10	Rp 3/8"	12	72	32	92	75	30	1.85
15	Rp 1/2"	14	72	32	92	75	30	1.9
20	Rp 3/4"	16	72	32	92	75	30	2.0
25	Rp 1"	18	78	41	107	85	32	2.6
32	Rp 1 1/4"	20	88	55	115	90	33	3.5
40	Rp 1 1/2"	22	96	60	132	100	35	4.3
50	Rp 2"	24	118	70	150	110	42	7.4

## Form 13IG / threaded connection

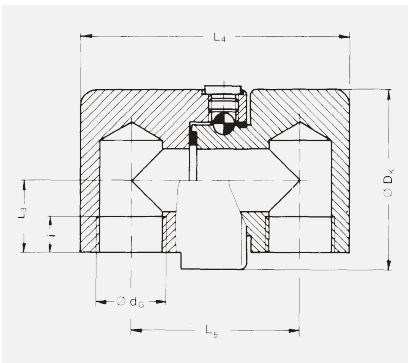

DN	$\varnothing d_G$ Zoll	i mm	$\varnothing D_k$ mm	$S_w$ mm	$L_3$ mm	$L_4$ mm	$L_5$ mm	weight approx. kg
8	Rp 1/4"	12	72	30	92	110	75	2.5
10	Rp 3/8"	12	72	30	92	110	75	2.6
15	Rp 1/2"	14	72	30	92	110	75	2.7
20	Rp 3/4"	16	72	30	92	110	75	2.8
25	Rp 1"	18	80	32	107	130	85	3.8
32	Rp 1 1/4"	20	88	33	115	152	100	5.8
40	Rp 1 1/2"	22	96	35	132	175	110	6.4
50	Rp 2"	24	118	42	150	208	128	11.5