

## Rubber expansion joint - Type A-3

Angular expansion joint DN 32 – DN 1000



### Applications

- for compensating angular movement
- as double or triple joint compensation system for large movements
  - for ground and foundation settlement
  - for tank settlement during filling
  - in plastic pipe systems
  - apparatus engineering and tank construction
  - power station technology

### Structure type A-3

- Angular expansion joint consisting of a rubber bellows and flanges
- Welded hinge restraints to absorb reaction force from internal pressure or vacuum

### Rubber bellows PN 16

- Highly elastic molded bellows in various rubber grades
- Synthetic fibre reinforcement
- Wire-reinforced self-sealing rubber rim
- Electrical impedance  $10^3$  to  $10^6$  Ohm (DIN IEC 93, VDE 0303-30)

Rubber grade*	Colour code	Possible uses
EPDM	orange	Hot water, acids, lyes
NBR	red	Oil
CIIR	white	Drinking water

\*Check or inquire about the resistance of the rubber grade to temperature and medium.

### Technical design

Max. perm. operating pressure	16 bar*
Max. perm. temperature	+100 °C
Bursting pressure	≥ 48 bar
Vacuum operation	DN 32-50 without vacuum supporting ring, DN 65-1000 with vacuum supporting ring

Max. operating pressure to be set 30 % lower for shock loads.

\*Please consider a decrease of pressure due to temperature (see technical annex).

### Flanges

#### Version

- Oval flanges with stabilizing collar and hinge restraints
- Flange drilling for through bolts
- Special machined groove for rubber rim

#### Dimensions

Standard: DN 32 - DN 175 (PN 16)  
 DN 200 - DN 1000 (PN 10)  
 DN 32 - DN 400 (PN 6)  
 according to EN 1092

Others: DIN EN, ANSI, BS etc.

Connection dimensions see technical

annex

#### Materials

Standard: 1.0038 (S235JR)

Others: stainless steel, etc.

#### Corrosion protection

Standard: DN 32 - DN 175

electrogalvanized  
 DN 200 - DN 1000  
 anti-corrosion primed

Others: hot-dip galvanized, special varnish, special coating, etc.

### Hinge restraints

- Pivot of joint bars at center of bellows
- Hinge restraints control bellows movement

### Materials

Standard: 1.0038 (S235JR),

1.0577 (S355J2)

Others: stainless steel, etc.

### Corrosion protection

Standard: DN 32 - DN 175  
 electrogalvanized  
 DN 200 - DN 1000

anti-corrosion primed  
 Others: hot-dip galvanized, special varnish and coating, etc

### Accessories

- Vacuum supporting ring
- Internal guide sleeve
- Flame-proof protective cover
- Protective hood

### Certificates

- CE (DGR 97/23/EC)
  - Bureau Veritas
  - Det Norske Veritas
  - Lloyd's Register of Shipping
  - Drinking water
  - TÜV (KTA)
- Others see technical annex



## Dimensions standard program

DN	BL*	Pressure rate	Ø di Bellows inner Ø	Ø C Raised face outer Ø	Ø E Raised face inner Ø	Ø W Convolution Ø unpressurized	PN Flange connection EN 1092	Ø D Flange outer Ø	b Flange thickness	H Flange height
32	125	16	31±3	72	39	78	16	140	16	220
40	125	16	39±3	81	45	86	16	150	16	230
50	125	16	49±3	95	56	97	16	165	16	240
65	125	16	65±3	115	72	113	16	185	18	260
80	150	16	77±3	127	84	135	16	200	20	300
100	150	16	100±3	151	109	160	16	220	20	350
125	150	16	127±3	178	133	184	16	250	22	385
150	150	16	153±3	206	161	212	16	285	22	420
175	150	16	176±3	230	185	236	16	315	22	445
200	175	10	202±3	260	209	265	10	340	25	470
250	175	10	252±3	313	262	318	10	395	25	530
300	200	10	303±3	363	312	373	10	445	25	550
350	200	10	344±3	423	360	420	10	505	30	645
400	200	10	396±3	474	410	460	10	565	30	740
450	250	10	435±8	532	450	575	10	615	40	845
500	250	10	485±8	584	500	625	10	670	40	895
600	250	10	585±8	684	600	725	10	780	45	1020
700	275	6	690±10	800	700	850	10	895	45	1140
800	275	6	790±10	900	800	950	10	1015	45	1285
900	300	4	890±10	1008	900	1050	10	1115	50	1385
1000	300	4	990±10	1108	1000	1150	10	1230	55	1485

From DN 200 higher pressure rate available on request.

\*The measure BL (length) for DN 400 - 1000 is approx. 6 mm shorter when fitted.

## Movement compensation

DN	Δ ang Angular movement ± degrees*	Weight approx. kg
32	25	6.0
40	25	6.5
50	25	7.2
65	25	8.6
80	20	12.1
100	15	14.0
125	15	17.6
150	12	20.4
175	10	23.1
200	8	34.5
250	7	39.6
300	6	45.2
350	5	70.0
400	5	95.0
450	8	155.0
500	7	190.0
600	6	250.0
700	5	290.0
800	5	360.0
900	4	425.0
1000	3.5	550.0

## Note

Please comply with the general technical instructions regarding reaction force, moving force, fixed point load, installation instructions etc.

Subject to technical alterations and deviations resulting from the manufacturing process.

## Flange versions

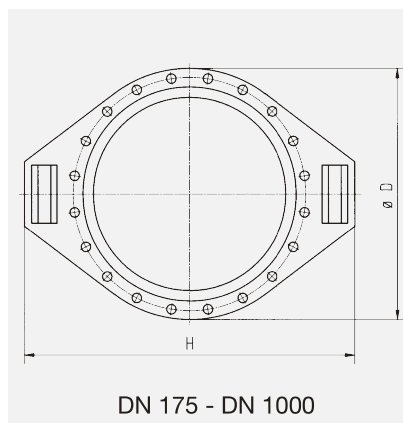
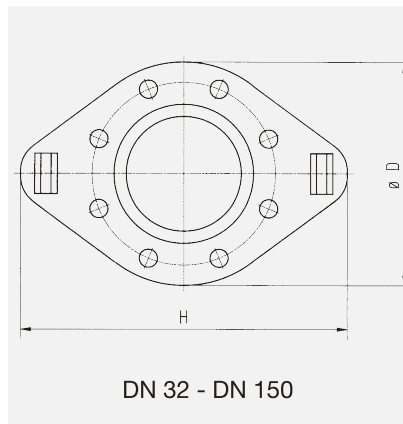

## Versions

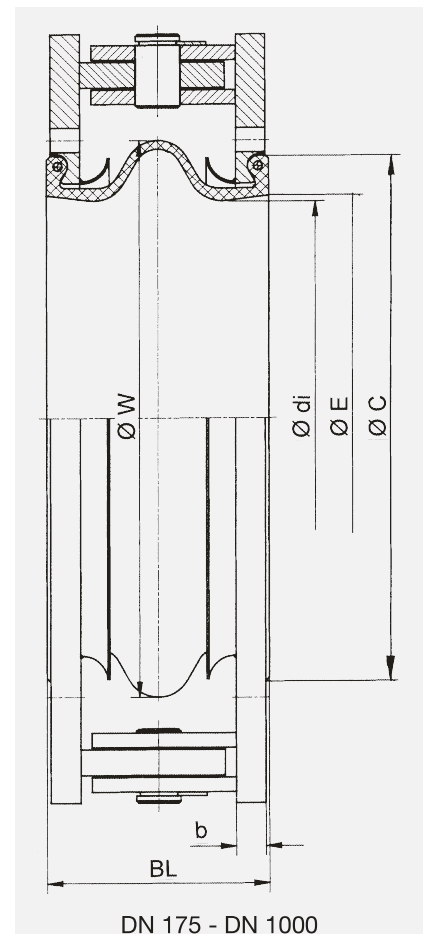
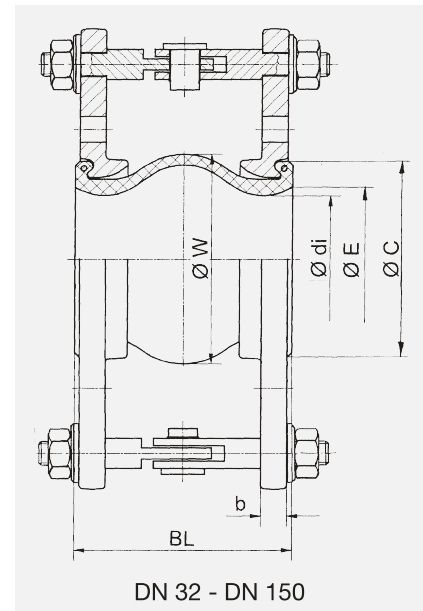

## Type A-3

Angular expansion joint with hinge restraints