

Rubber expansion joint - Type R-1

Universal expansion joint DN 25 – DN 300



Structure type R-1

Universal expansion joint consisting of a rubber bellows and rotatable flanges

Rubber bellows PN 16

- Flat-convoluted molded bellows in various rubber grades
- Synthetic fibre reinforcement
- Wire-reinforced self-sealing rubber rim
- Electrical impedance 10³ to 10⁶ Ohm (DIN IEC 93, VDE 0303-30)

Rubber grade*	Colour code	Possible uses
EPDM	orange	Hot water, acids, lyes
NBR	red	Oil
CIIR	white	Drinking water

*Check or inquire about the resistance of the rubber grade to temperature and medium.

Technical design

Max. perm. operating pressure	16 bar*
Max. perm. temperature	+100 °C
Bursting pressure	≥ 48 bar
Vacuum operation	DN 25-50 without vacuum supporting ring, DN 65-300 with vacuum supporting ring

Max. operating pressure to be set 30 % lower for shock loads.

*Please consider a decrease of pressure due to temperature (see technical annex).

Flanges

Version

- Rotable flanges with stabilizing collar
- Flange drilling for through bolts, DN 25 with Drill holes
- Special machined groove for rubber rim

Dimensions

Standard: DN 25 - DN 150 (PN 16)
 DN 200 - DN 300 (PN 10)
 DN 25 - DN 300 (PN 6)
 according to EN 1092

Others: DIN EN, ANSI, BS etc.

Connection dimensions see technical annex

Materials

Standard: 1.0038 (S235JR)
 Others: 1.4541, 1.4571

Corrosion protection

Standard: electrogalvanized
 Others: hot-dip galvanized, special varnish, special coating, etc.

Applications

- for reducing thermal and mechanical tension in pipes and their system components, e.g.
 - pumps
 - compressors
 - motors
- for muffling vibration and noise
- for compensating axial, lateral and angular movement
- to compensate for installation inaccuracies
- as installation and dismantling aid

Accessories

- Vacuum supporting ring
- Internal guide sleeve
- Flame-proof protective cover
- Protective hood
- Protective tube

Certificates

- CE (DGR 97/23/EC)
- Bureau Veritas
- Lloyd's Register of shipping
- Det Norske Veritas
- Drinking water



STENFLEX® type R-1
 in a proportioning system

Dimensions standard program

DN	BL	Pressure rate	∅ di Bellows inner ∅	∅ C Raised face outer ∅	∅ E Raised face inner ∅	∅ W Convolution ∅ unpressurized	PN Flange connection EN 1092	∅ D Flange outer ∅	b Flange thickness
	mm	bar	mm	mm	mm	mm		mm	mm
25	130	16	31±3	72	39	88	16	115	16
32	130	16	31±3	72	39	88	16	140	16
40	130	16	39±3	81	45	96	16	150	16
50	130	16	49±3	95	56	107	16	165	16
65	130	16	65±3	115	72	123	16	185	18
80	130	16	77±3	127	84	135	16	200	20
100	130	16	100±3	151	109	160	16	220	20
125	130	16	127±3	178	133	184	16	250	22
150	130	16	153±3	206	161	212	16	285	22
200	130	10	202±3	260	209	260	10	340	25
250	130	10	252±3	313	262	313	10	395	25
300	130	10	303±3	363	312	363	10	445	25

From DN 200 pressure rate 16 bar also available with flanges PN 16.

Movement compensation/bellows cross sectional area

DN	∆ ax Axial movement		∆ lat Lateral movement ± mm	∆ ang* Angular movement ± \angle degrees*	A** Effective bellows cross sectional area at 16 bar cm ²	Permissible vacuum without supporting ring at length BL bar absolute	Weight approx. kg
	Compression - mm	Elongation + mm					
25	35	10	15	25	8	-	2.2
32	35	10	15	25	8	0.6	3.3
40	35	10	15	25	9	0.6	3.8
50	35	10	15	25	19	0.6	4.5
65	35	10	15	25	33	0.7	5.2
80	30	10	15	20	53	0.65	7.1
100	30	10	15	15	98	0.6	8.0
125	30	10	15	15	103	0.75	10.5
150	30	10	15	10	203	0.65	12.8
200	25	10	15	7	379	0.7	18.2
250	25	10	15	6	525	0.7	23.7
300	20	10	15	5	769	0.8	30.4

* Larger ∆ ang possible for compressed installation length. Please inquire for simultaneous (different) movement.

**Effective bellows cross sectional area is a theoretical value.

Note

Please comply with the general technical instructions regarding reaction force, moving force, fixed point load, installation instructions etc.

Subject to technical alterations and deviations resulting from the manufacturing process.

Version

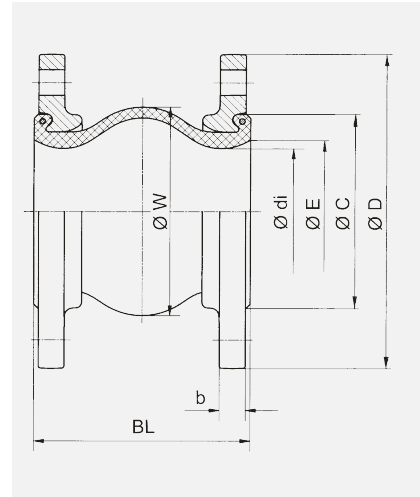

Type R-1

Universal expansion joint without restraint