

RUBBER EXPANSION JOINT TYPE AS-2, AS-4

FLAME-PROOF

LATERAL EXPANSION JOINT DN 25 – DN 400

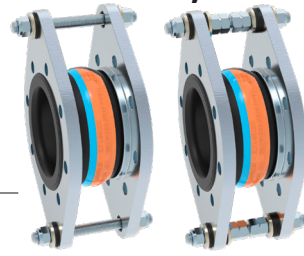

STRUCTURE TYPE AS-2, AS-4 / RUBBER BELLOWS PN 16

- **Type AS-2:** Lateral expansion joint consisting of a rubber bellows with rotatable flanges and tie rods (external restraints) to absorb reaction force from internal pressure
- **Type AS-4:** Lateral expansion joint consisting of a rubber bellows with rotatable flanges and tie rods (external and internal restraints) to absorb reaction force from internal pressure or vacuum
- Highly elastic molded bellows in various rubber grades
- Steel wire cord reinforcement
- Wire-reinforced self-sealing rubber rim
- Electrical impedance 10^3 to 10^6 Ohm (DIN IEC 93, VDE 0303-30)

Rubber grade*	EPDM	NBR
Colour code	orange/blue	red/blue
Possible uses	Hot water, acids, lyes	hydrocarbon containing liquids

*Check or inquire about the resistance of the rubber grade to temperature and medium

Technical design	
Max. perm. operating pressure	16 bar*
Max. perm. temperature	+130 °C
Bursting pressure	≥ 50 bar
Vacuum operation	DN 32 – 50 without vacuum supporting ring, DN 65 – 400 with vacuum supporting ring

Max. operating pressure to be set 30 % lower for shock loads.

*Please consider a decrease of pressure due to temperature (see technical annex).

FLANGES / VERSIONS

- Flanges with stabilizing collar and ears to carry the tie rods
- Flange drilling for through bolts, DN 25 with Drill holes
- Special machined groove for rubber rim

	Standard	Others
Dimensions	EN 1092	ANSI, BS etc. Connection dimensions see technical annex page 213 – 215
Materials	1.0038 (S235JR)	1.4541, 1.4571 etc.
Corrosion protection	electrogalvanized	hot-dip galvanized, special varnish, special coating, etc.

NOTE

Subject to technical alterations and deviations resulting from the manufacturing process.

Chemicals used for water treatment (particularly in heating systems and coolant systems) can corrode the materials of the rubber expansion joint. According to VDI Directive 2035, DIN 4809 part 1 and VGB R 455P, the manufacturer of the chemicals must state that the materials used in the expansion joint, especially for the rubber bellows, will not be damaged by the chemicals.

APPLICATIONS

- for reducing thermal and mechanical tension in pipes and their system components, e.g.
 - pumps
 - compressors
 - engines
- for muffling vibration and noise
 - at appliances
 - in cooling water and lub oil pipes
- for compensating lateral movement
- to compensate for installation inaccuracies
- to meet fire protection regulations
- shipbuilding industry
- in heating plants

TIE ROD RESTRAINTS

- DN 25 – DN 150 Tie rods carried on silencing rubber sockets
- DN 175 – DN 400 Tie rods carried on spherical washers and conical seats

Materials

Standard: tie rods 8.8

Others: stainless steel

Corrosion protection

Standard: electrogalvanized

Others: hot-dip galvanized

DIMENSIONS STANDARD PROGRAM

DN	BL	Pressure rate	Ø dj Bellows inner Ø	Ø C Raised face outer Ø	Ø E Raised face inner Ø	Ø W* Con-volution Ø	PN Flange connection EN 1092	Ø D Flange outer Ø	b Flange thickness	H Flange height
	mm	bar	mm	mm	mm	mm		mm	mm	mm
25	125	16	31 ± 3	72	39	78	16	115	16	220
32	125	16	31 ± 3	72	39	78	16	140	16	220
32	150	16	31 ± 3	72	39	88	16	140	16	220
40	125	16	39 ± 3	81	45	86	16	150	16	230
40	150	16	39 ± 3	81	45	96	16	150	16	230
50	125	16	49 ± 3	95	56	97	16	165	16	240
50	150	16	49 ± 3	95	56	107	16	165	16	240
65	125	16	65 ± 3	115	72	113	16	185	18	260
65	150	16	65 ± 3	115	72	123	16	185	18	260
80	150	16	77 ± 3	127	84	135	16	200	20	300
100	150	16	100 ± 3	151	109	160	16	220	20	350
125	150	16	127 ± 3	178	133	184	16	250	22	385
150	150	16	153 ± 3	206	161	212	16	285	22	420
175	150	16	176 ± 3	230	185	236	16	315	22	440
200	150	10	202 ± 3	260	209	265	10	340	25	465
200	175	10	202 ± 3	260	209	265	10	340	25	465
250	175	10	252 ± 3	313	262	318	10	395	25	520
250	200	10	252 ± 3	313	262	318	10	395	25	520
300	200	10	303 ± 3	363	312	373	10	445	25	570
350	200	10	344 ± 3	423	360	420	10	505	30	630
400	200	10	396 ± 3	474	410	460	10	565	30	690

*unpressurized. From DN 200 higher pressure rate available on request. Please contact us for further flange dimensions.

MOVEMENT COMPENSATION / FLANGE VERSIONS

DN	BL	Δ lat Lateral movement ± mm	Permissible vacuum w/o supporting ring at length BL bar absolute	Weight type AS-2 approx. kg
	mm			
25	125	15	0	4.2
32	125	15	0	5.1
32	150	20	0.5	5.2
40	125	15	0	5.6
40	150	20	0.7	5.7
50	125	15	0	6.2
50	150	20	0.7	6.4
65	125	15	0	7.9
65	150	20	0.7	8.1
80	150	15	0.2	10.7
100	150	15	0.4	12.6
125	150	15	0.65	16.8
150	150	15	0.65	19.6
175	150	15	0.7	20.3
200	150	15	0.8	22.9
200	175	15	0.7	23.2
250	175	15	0.7	28.1
250	200	15	0.5	28.4
300	200	15	0.75	32.2
350	200	15	0.5	44.7
400	200	15	0.3	58.6

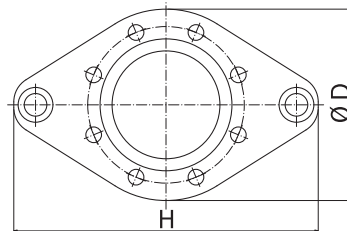

DN 25 - DN 150

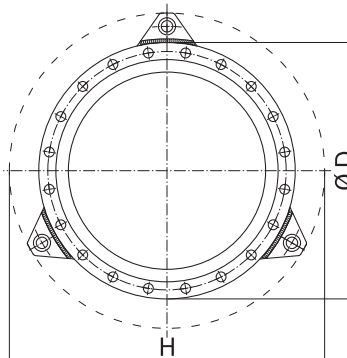

DN 175 - DN 400

Number of tie rods depending on pressure

CERTIFICATES

- CE (PED 2014/68/EU)
- American Bureau of Shipping
- Bureau Veritas
- MED
- DNV GL® / DNV®
- Lloyd's Register of Shipping
- TÜV/DIN 4809
- TÜV Süd (KTA)
- Others see technical annex

ACCESSORIES

- Vacuum supporting ring
- Internal guide sleeve
- Protective hood
- Protective tube

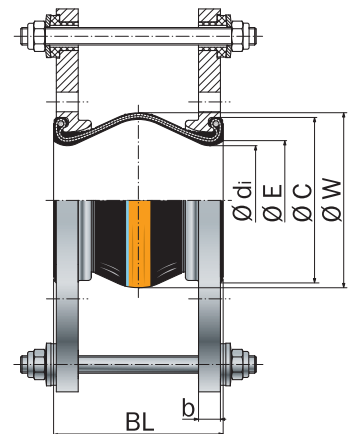

Type AS-2

Tie rods, external restraints, carried on silencing rubber sockets

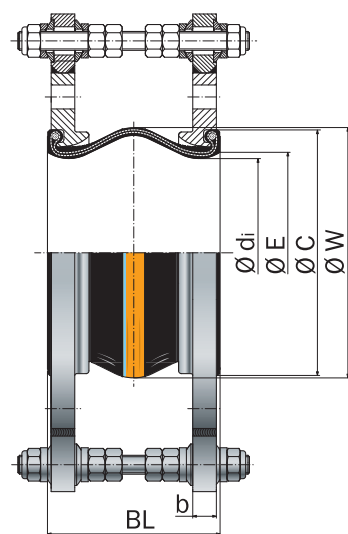

Type AS-4

Design as type AS-2, additional internal restraints, carried on spherical washers and conical seats