



**FLEXIBLE
PIPE CONNECTIONS
GENERAL CATALOGUE**

CONTENTS

STENFLEX

	Page
Our Company	6
Applications	7
Summary	9
How can we help you?	10
We aim for quality!	12

RUBBER EXPANSION JOINTS

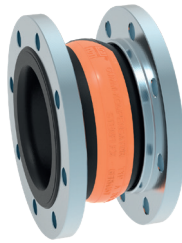

General description	
Purpose	16
Development/Design	17
Versions	17
Rubber bellows	
▪ Structure	18
▪ Material qualities	19
Connection parts	
▪ Flanges	20
▪ Threaded connections	21
Restraints	
▪ Tie rod restraints	21
▪ Hinge restraints	22
Accessories	
▪ Vacuum supporting rings	22
▪ Guide sleeves	22
▪ Protective covers	22
Compensation systems	24
Applications/Possible uses/Industries	26
Program summary	
▪ rubber expansion joints	27
Data sheets	
▪ rubber expansion joints	30 - 85

PIPE CONNECTORS



General description	
Purpose	88
Development/Design	88
Versions	88
▪ Structure	88
Connection parts	88
▪ Flanges	88
Applications/Possible uses/Industries	89
Program summary	
▪ Rubber-metal pipe connectors	89
Data sheets	
▪ Rubber-metal pipe connectors	90 - 91

STEEL EXPANSION JOINTS

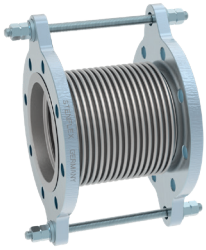

General description	
Purpose	94
Development/Design	95
Versions	95
Steel bellows	
▪ Structure	96
▪ Material qualities	96
▪ Rating, service life	97
Connection parts	
▪ Flanges	97
▪ Welding ends	98
▪ Threaded connections	98
Restraints	
▪ Tie rod restraints	99
▪ Hinge restraints	100
Accessories	
▪ Internal guide sleeves	100
▪ Guide sleeves	101
▪ Protective covers	101
Compensation systems	102
Applications/Possible uses/Industries	104
Program summary	
▪ Axial steel expansion joints	105
▪ Lateral steel expansion joints	106
▪ Angular steel expansion joints	107
Data sheets	
▪ Axial steel expansion joints	108 - 123
▪ Lateral steel expansion joints	124 - 134
▪ Angular steel expansion joints	135 - 137

**QUALITY.
STENFLEX.**

PTFE EXPANSION JOINTS



General description	
Purpose	140
Development/Design	140
Versions	140
PTFE bellows	
▪ Structure	141
▪ Material qualities	141
Connection parts	
▪ Flanges	142
Restraints	
▪ Tie rod restraints	143
Accessories	
▪ Internal guide sleeves	144
▪ Protective covers	144
Applications/Possible uses/Industries	145
Program summary	
▪ PTFE expansion joints	145
Data sheets	
▪ Rubber expansion joints with PTFE Inliner	146 - 149
▪ PTFE expansion joints	150 - 153

CONTENTS

STENFLEX



SWIVEL JOINTS

	Page
General description	
Applications/possible uses	156
Possible uses/Applications/Technical Data	157
Structure	
▪ Basic unit	158
▪ Standard sealings	158
▪ Special sealings	158
▪ Materials	158
▪ Surface protection	158
Connections/Interpretatia/Tests	
▪ Connections	159
▪ Temperature range	159
▪ Pressure ratings	159
▪ Tolerances	159
▪ Tests	159
▪ Notes	159
Type of compensation	160
Forms	161
Data sheets	162 - 171

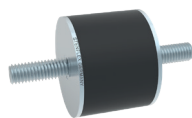

RUBBER-METAL ELEMENTS

General description	
Purpose	174
Development/Design/Rating	175 - 176
Definitions	
▪ Attenuation (damping)	177
▪ Elasticity	177
▪ Ozone resistance	177
▪ Deformation	177
▪ Hardness	177
▪ Adhesion	177
▪ Processing	177
▪ Tolerances	177
▪ Versions	178 - 179
▪ Special versions	179
Rubber-metal elements	
▪ Structure	180
▪ Material qualities	180
Connection parts	180
Applications/Properties/Possible uses/Industries	181

RUBBER-METAL ELEMENTS

Program summary

▪ Stopper buffer	182
▪ Buffer elements	182
▪ Ceiling elements	182
▪ Rails	182
▪ Machine feet	183
▪ Bearing elements	183

Data sheets

▪ Rubber-metal elements	184 - 195
-------------------------	-----------

**QUALITY.
STENFLEX.**

TECHNICAL ANNEX

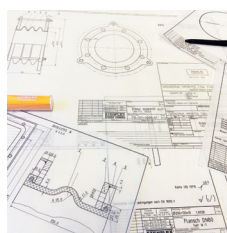

Movement and force at expansion joints

▪ Movement	198
▪ Force of axial and universal expansion joints	199
▪ Force of lateral expansion joints	199
▪ Moment of angular expansion joints	199

Pipe fixed points

▪ Arrangement of fixed points/guide bearings for axial expansion joints	201
▪ Arrangement of fixed points for lateral/angular expansion joints	201
▪ Arrangement of fixed points at pumps	201

Reducing the sound level by rubber expansion joints

▪ Reducing the sound level, example type AS	202
---	-----

Absorbing expansion by steel expansion joints

▪ Thermal expansion of pipes	203
▪ Absorption of expansion by not pre-tensioned expansion joints	203
▪ Absorption of expansion by pre-tensioned expansion joints	203
▪ Absorption of expansion/influence of temperature and movement	204

Installation and operating instructions for rubber expansion joints and pipe connectors

▪ Installation	205 - 206
▪ Initial commissioning/Use	206
▪ Inspection/Instructions/Declaration of conformity	207

Installation and operating instructions for steel expansion joints

▪ Installation/Initial commissioning	208
▪ Use/Inspection/Instructions/Declaration of conformity	209

Installation and operating instructions for rubber-metal elements

▪ Installation/Initial commissioning/Inspection	210
---	-----

Quality assurance

▪ Quality management system	211
-----------------------------	-----

Certificates

▪ Rubber expansion joints and pipe connectors	212
▪ Steel expansion joints	212

Flange connection dimensions	213 - 215
-------------------------------------	-----------

Comparison and conversion tables	216
---	-----

Glossar	217 - 219
----------------	-----------

Inquiry/order forms

▪ Rubber/PTFE/Fabric expansion joints, pipe connectors	220
▪ Steel expansion joints	221
▪ Swivel joints	222

STENFLEX® International

Headquarters, subsidiaries and agencies	223 - 224
---	-----------

STENFLEX® – SETTING STANDARDS!

For 50 years, industrial pipeline construction applications throughout the world have relied on flexible pipe connections by STENFLEX®, the specialists for high-quality construction elements in:

- Nuclear power plants, conventional power plants and large-scale plant construction
- Heating, ventilation and air conditioning, as well as drinking water and waste water engineering
- Mechanical engineering, motor production, industrial equipment construction
- Shipbuilding and ships chandlers, as well as the foodstuff and chemical industries

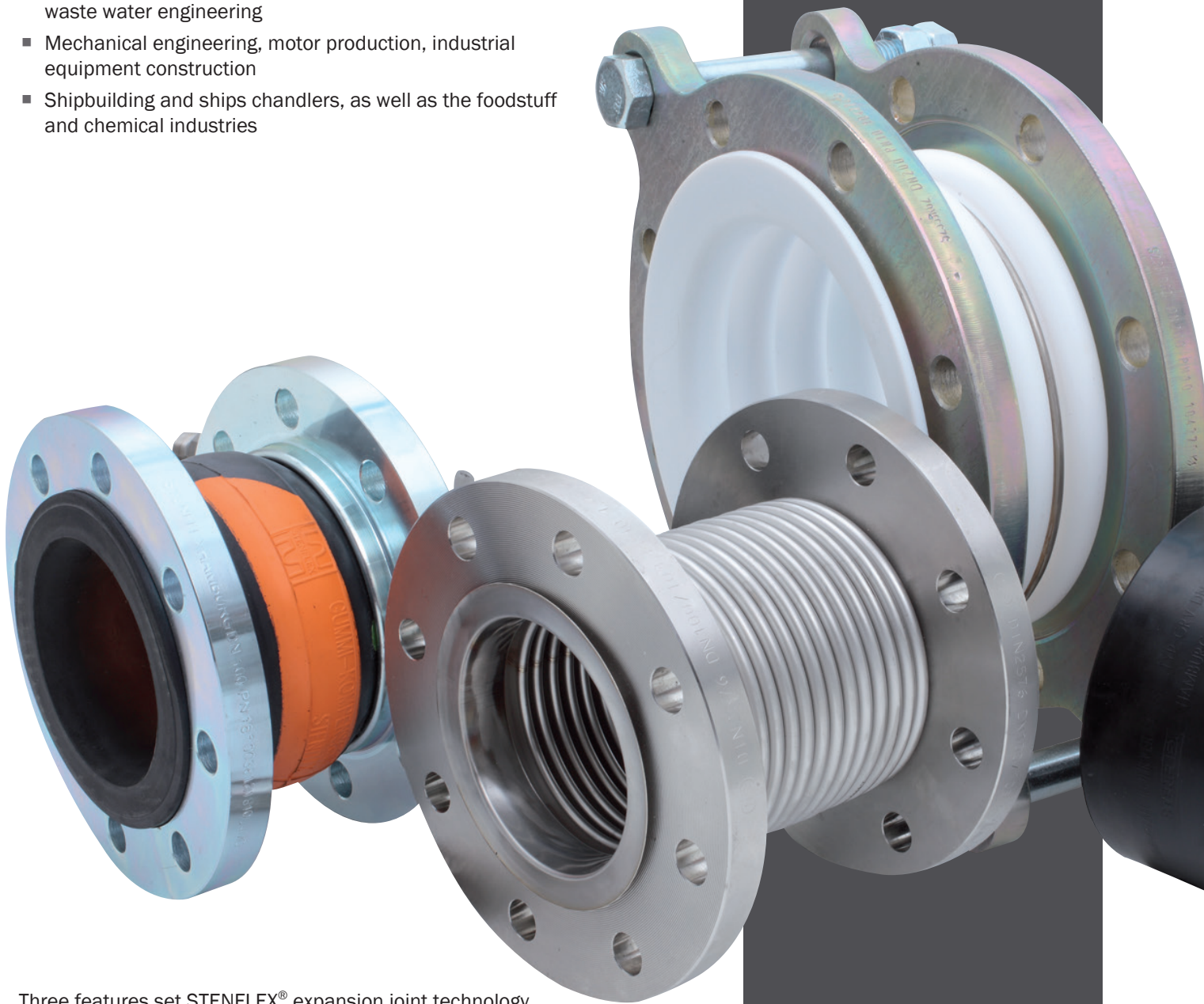

Three features set STENFLEX® expansion joint technology apart: It is entirely maintenance-free, highly reliable in application and extremely durable.

This means that operators can rely on our expansion joints for cost-effectiveness and sustainability.

TECHNICAL SOLUTIONS

We make it possible: Technical support from STENFLEX®

STENFLEX® engineers combine experience and know-how gained throughout five decades of market leadership in the field of flexible pipe connectors.

The CAD experts of our design and engineering department actively seek and appreciate dialogue with the industry and their customers which they then use to turn technical innovations into products that meet requirements and conform to applicable standards.

What we can offer you at STENFLEX®:

- Technical support in the selection of suitable pipe connectors taking installation and planning guidelines into account
- Application-based dimensioning and calculation of expansion joints
- Offers including drawings with technical data and installation dimensions
- Continuous product optimisation in line with up-to-date technical advances and developments, taking into account the requirements of applicable standards and regulations
- Innovations tailored to respond to the needs of the market

... AIMING BEYOND THE BENCHMARK!

STENFLEX® expansion joints are used in a wide variety of applications. Proven STENFLEX® quality has traditionally been relied upon in the following sectors:



APPLICATIONS

- Mechanical engineering, motor production and industrial equipment construction, as well as on turbines and compressors
- Building service engineering utilities: Heating, ventilation and air conditioning, as well as drinking water and waste water engineering
- Power engineering of nuclear plants, conventional power plants and large-scale plant construction
- Ship building and ships chandlers
- Waste incineration
- Dedusting and filtering technology
- Materials handling
- Water supply and water treatment
- Process engineering
- Chemicals industry, petro-chemicals and refineries
- Metal construction, smelting works and steelworks
- Paper, beverages and foodstuffs industries
- Gas and water supply as well as water treatment plants
- Heat supply and district heating plants
- Environmental engineering, incinerators
- Hydraulic installations and rolling mills



PRODUCT APPLICATIONS

SUMMARY

Products	Rubber expansion joints	Vibration and noise absorbers	Steel expansion joints	PTFE expansion joints	Swivel joints	Rubber-metal bearing elements
This table contains the main applications for STENFLEX® products						
Absorption of pipe expansion and movement (axial, lateral, angular)	■		■	■	■	
Absorption of vibration/oscillation and noise	■	■	■	■		■
Tension reduction	■	■	■	■		
Absorption of rotational movement and torsion					■	
Compensation of pipeline offsets (installation inaccuracies, ground settling)	■		■	■		
Dismantling pieces on fittings	■	■	■	■		
Elastic reduction adapters in pipes	■					
Elastic wall sealing systems	■					
Rotary lead-through systems, loading systems					■	
Conveyance of particularly aggressive media				■		
Mountings of machines and apparatus						■

BEING STENFLEX® – WHAT IT MEANS TO US

Established in 1965, STENFLEX® today develops, produces and supplies flexible pipe connections to customers through-out the world. The company's product portfolio includes rubber and steel expansion joints, PTFE expansion joints, pipe connectors, swivel joints and rubber-metal bearing elements.

STENFLEX® offers something exceptional in terms of the quality, value and durability of its products. The STENFLEX® brand has become inextricably linked with rubber and steel expansion joints made of traditional materials such as EPDM, NBR, butyl and stainless steel. These provide the optimum conditions for absorbing motion and noise.

STENFLEX® stands for delayed material aging, thanks to protective components, absolute and sustained flange-sealing and ease of installation. Add to this high resistance to pressure surges thanks to vulcanised reinforcing materials made of synthetic fibres and steel wire – all this at maximum cost-effectiveness.

We owe our success to the following core competences:

- Ongoing development of the product range
- Comprehensive customer service thanks to an international sales network
- Maximum reliability and adherence to deadlines
- Uncompromising customer focus
- Responsibility towards our customers and their needs
- Consistently superior product quality, compliant with DIN EN ISO 9001:2015

SERVICE

PHILOSOPHY

From our point of view, corporate success is inextricably linked to responsibility. This we accept gladly – for the benefit of our customers, our employees and our environment.

The key to satisfying our customers lies in the proven dependability of the support we give, the service we offer and the state-of-the-art quality of all STENFLEX® products.

STENFLEX® leads the field in innovation and expertise. This expertise grows with every order we fulfill and benefits our customers, who gain access to 50 years of specialty know-how and engineering.

It is STENFLEX® company policy that we actively promote a culture of mutual respect within our organisation, and towards our corporate partners. And are committed to fair conduct towards our competitors.

REVISION

PROFESSIONAL INSPECTION FOR RELIABLE LONG-TERM OPERATION

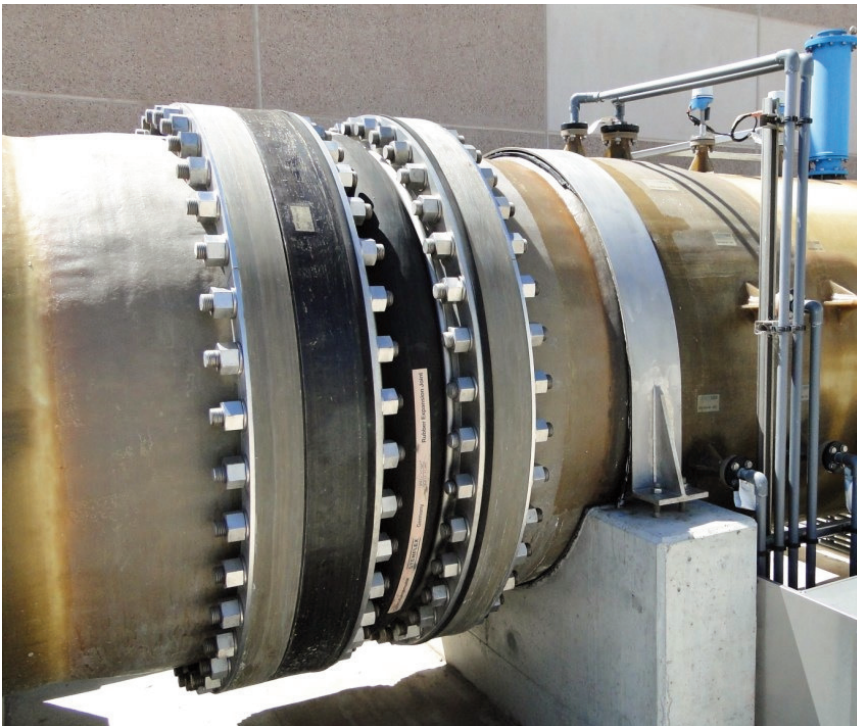

STENFLEX® offers regular inspections to ensure reliable plant operation

STENFLEX® stands for exceptional reliability and sustained performance when it comes to pipe connections. The guarantees we provide for new components should also apply to equipment which is already in operation. For this reason we offer a revision service for all installed expansion joints comprising the inspection and evaluation of equipment.

This typically involves STENFLEX® employees measuring the hardness of the rubber, checking the installation position and visually inspecting the bellows for possible damage such as bubbles and tears, or layer separation. This inspection will identify defects on both the exterior surface and the inside of the bellows.

Once the revision process is complete, customers (such as operators of power plants and industrial installations) receive a written inspection report containing recommendations for maintenance work along with proposals to replace outdated expansion joints, should this be necessary.

STENFLEX®

Stahl-Kompensatoren
Steel-Type expansion joints
Compensateurs en acier
Compensadores de acero
Compensatori d'acciaio
Stålkompensatorer
χαλύβιδων διαστολικών
Ocelové kompenzátory

Montage- und Betriebsanleitung
Installation and operating instructions
Notice de montage et de service
Instrucciones para el montaje y el servicio
Istruzioni per il montaggio e l'esercizio
Monterings- och bruksanvisning
Οδηγίες τοποθέτησης και λειτουργίας
Návod k montáži a obsluze

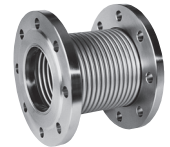

B21110.00001984-00



STENFLEX®

Rohrdrehgelenke
Swivel joints
Joints tournants
Articulaciones giratorias
Giunti girevoli per tubi
Kullänkar
αρθρώσεις σωλήνων
Ότοσνήχ κλουβύ

Montage- und Betriebsanleitung
Installation and operating instructions
Notice de montage et de service
Instrucciones para el montaje y el servicio
Istruzioni per il montaggio e l'esercizio
Monterings- och bruksanvisning
περιστρεφόμενες αρθρώσεις σωλήνων
Ότοσνήχ κλουβύ



D141.00001998-00



STENFLEX®

Gummi-Kompensatoren Typenreihe D
Rubber expansion joints Type Series D
Compensateurs en élastomère de types D
Compensadores de goma Serie D
Compensatori di gomma della serie tipo D
Gummi-kompensatorer typserie D
ελαστικά αντικραδασμικά της σειράς D
Gumové kompenzátory typové řady D

Montage- und Betriebsanleitung
Installation and operating instructions
Notice de montage et de service
Instrucciones para el montaje y el servicio
Istruzioni per il montaggio e l'esercizio
Monterings- och bruksanvisning
Οδηγίες τοποθέτησης και λειτουργίας
Návod k montáži a obsluze



G171.00000966-00



QUALITY MANAGEMENT

STENFLEX® IS SETTING A HIGH STANDARD

Our flexible pipe connections are designed and dimensioned in compliance with national and international regulatory standards. The optimum quality of STENFLEX® products has been confirmed by approval bodies and independent test institutes worldwide.

To ensure that our products and processes continue to remain at a consistently high level in future, we work in compliance with ISO 9001:2015.

Many of our products have achieved KTA 1401 approval for use in nuclear plants.

When it comes to quality, STENFLEX® promises the following:

- STENFLEX® production meets the highest quality demands. Our design and engineering department will continue to introduce innovations and product improvements.
- STENFLEX® products have been approved by international classification bodies and independent testing institutes.
- STENFLEX® products stand out due to a multitude of successful component and performance tests.
- Before being put to use in practical applications, all type series undergo stringent testing in all manner of areas. These include fire resistance tests as well as burst, pressure and leak tests.
- Most type series are subject to the European Pressure Equipment Directive and are therefore CE-compliant.

Special tests and acceptance testing by authorities can be arranged for customers on request.



TYPE APPROVAL AND SUITABLE

CERTIFICATION AND APPROVALS

STENFLEX® has attained all major and approved national and international manufacturer certificates, component tests and special Certificates of Competence. Our production processes are based on the ISO 9001:2015 quality management system, which has been in use throughout our organisation for a number of years.

CERTIFIED QUALITY MANAGEMENT SYSTEM IN ACCORDANCE WITH:



EN ISO 9001:2015
Management service Quality seal



VGB Powertech
Certified for nuclear facilities
Suitability approval for quality assurance
Approval according to KTA 1401



CE-marking
Tested according to
PED 2014/68/EU



DIN approved
Tested for DIN 4809
registered number: 3 E002

CLASSIFICATION AND CERTIFICATION BODIES:



ABS
Type Approvals



China Corporation Register of Shipping
Type Approvals



Bureau Veritas
Type Approvals



Korean Register of Shipping
Type Approvals



DNV GL® / DNV®
Type Approvals



DIN DVGW
KTW-recommendation for drinking water
Certified for gas supply products



Lloyd's Register
Type Approvals



ACS
Certified for drinking water



Registro Italiano Navale
Type Approvals



WRAS
Certified for drinking water



Russian Maritime Register of Shipping
Type Approvals



FDA
Certified for foods



CCS (China Classification Society)
Type Approvals



DIN GOST TÜV
Certification GOST-R/TR

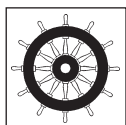

MED
Marine Equipment Directive
(protection against fire)



TÜV Rheinland DIN CERTCO
in accordance with DIN 4809



Nippon Kaiji Kyokai
Type Approvals



TÜV Anlagen und Umwelt
Testing for radioresistance

TESTING

RUBBER EXPANSION JOINTS PROGRAMME OVERVIEW

STENFLEX® **RUBBER EXPANSION JOINTS**
ARE USED TO ABSORB MOVEMENTS AND
DAMP VIBRATION AND NOISE ON INDUSTRIAL
EQUIPMENT, MACHINERY AND PUMPS,
AS WELL AS IN PIPELINE SYSTEMS.

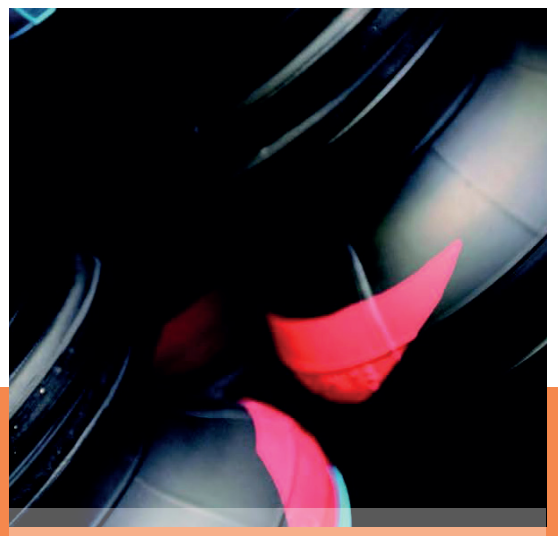
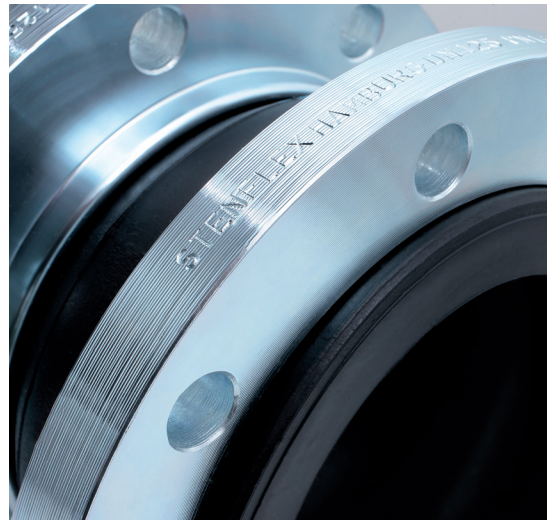

QUALITY.

RUBBER EXPANSION JOINTS

GENERAL DESCRIPTION OF RUBBER EXPANSION JOINTS

STENFLEX® rubber expansion joints have served with distinction for 50 years. They are the preferred flexible pipe connection elements of choice in manufactured appliances, machinery, apparatus and piping engineering.

Constant further development and innovations update our product range to meet the needs of current and changing markets. Numerous patent applications and on-going optimization of the formulae for our rubber grades ensure that our customers always receive state-of-the-art products; highly reliable and of superior durability.

The large-scale industrial manufacture of the rubber bellows, constant control of compliance with all manufacturing, business and quality processes in line with EN ISO 9001:2015 and decades of experience in the development and manufacture of rubber expansion joints: all this guarantees a uniform product of the highest standard. It underlines the STENFLEX® Quality Claim.

Nearly all nuclear plants throughout Europe are equipped with STENFLEX® expansion joints. Many of our rubber expansion joints have been used in a large variety of applications. They have served on site in trouble-free operation for decades. STENFLEX® rubber expansion joints have passed national and international Type Approvals and suitability tests and are certified by numerous classification societies.

Our engineers in the fields of mechanical-, and processing-plant engineering work hand-in-hand with our modern R & D department. They are always available for technical consultation and ready to help in solving specific application problems at any time.

DEVELOPMENT/DESIGN

STENFLEX® rubber expansion joints are rated by state-of-the-art computing techniques (which include the Finite Element Method). They are optimized under experimental conditions.

Our development engineers use the most up-to-date development tools throughout the development stage to validate the construction process in terms of form, function and installation.

This means we offer our customers the following advantages:

- Design and development in line with the specific requirements, resulting in safe and extremely durable expansion joints
- Efficient products by incorporating superior product functionality
- Structures that are easy to install
- Reduced lead times for special designs

The excellent features of STENFLEX® rubber expansion joints include outstanding absorption of movement and good vibration damping properties. Depending on the particular expansion joint type, a maximum of the forces produced by the pipe internal pressure is absorbed by the specific design of the expansion joint itself, and not passed on to neighbouring system components.

PURPOSE

Expansion joints are used in appliances, machinery, apparatus and pipe systems where space is limited:

- to compensate for movement
- to compensate for expansion caused by differences in temperature
- to reduce tension
- to absorb noise and vibration transmission
- to compensate for ground, and foundation settlement
- to compensate for pipeline movement aboard ships
- as adapters to compensate for installation inaccuracies
- as dismantling pieces for fittings
- as elastic sealing elements, where pipelines pass through walls

Rubber expansion joints are used in a variety of industrial applications:

- Machine engineering
- Domestic industry
- Processing plant engineering
- Power station technology
- Shipbuilding

VERSIONS

Rubber expansion joints differ according to the following criteria:

- type (universal/lateral/angular expansion joints)
- pipe connection type (flange, thread)
- rubber quality of the bellows (rated to the media transported in the pipes)
- bellows structure (rated to the pressure and temperature load)

Our expansion joints are delivered ready to install. Together with the standard versions featured in the catalogue, special versions can also be developed and produced on request for special operating conditions. Connection parts (that deviate from DIN) such as ISO, ANSI, BS, VG and SAE standards etc. are also possible.

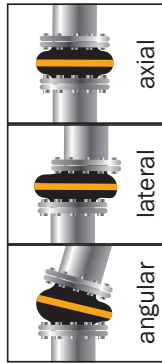
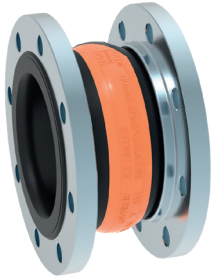

Universal rubber expansion joints

Structure: Rubber bellows with connection parts (flange or thread)

Movement absorption: Axial, lateral, angular and simultaneous movement absorption is possible. Universal expansion joints with two bellows and a connecting pipe are used to absorb large movement.

Fixed points: To absorb axial force a pipe's fixed points must be robust. Pipe routing must be correct.

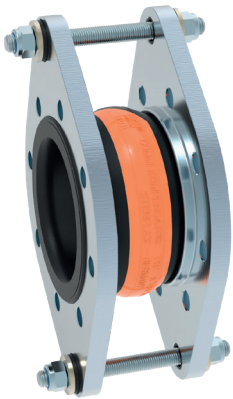

Lateral rubber expansion joints:

Structure: Rubber bellows with flanges and laterally movable restraints.

Movement absorption: Lateral shift of the expansion joints is possible. The restraint absorbs axial reaction force and relieves the pressure on the pipe's fixed points. In double joints the type of restraint allows for movement on one plane; in ball joints it allows for all-around movement. Lateral expansion joints with two bellows and a connecting pipe are used to absorb large movement.

Fixed points: Only light fixed points are required to absorb force from lateral movement and friction force.

Attention! Lateral expansion joints with tie rod restraints are not designed for axial adjusting movements. However, if axial adjusting movements are initiated, the tie rod restraints cannot compensate the compressive force and will be transferred to the fixed points of the piping instead.

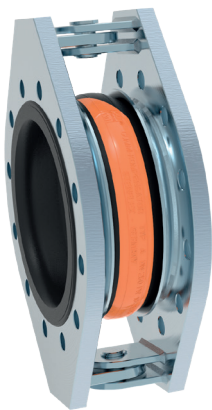

Angular rubber expansion joints:

Structure: Rubber bellows with flanges and hinge restraint. The rotating axis of the hinge restraint is in the middle of the bellows.

Movement absorption: Angular movement of the expansion joint is possible. The angular joints regulate a defined angular movement, absorb axial reaction force and relieve the pressure on the pipe's fixed points. We differentiate between angular expansion joints with a hinge (bellows' angular movement guided on one plane) and angular expansion joints with a cardan hinge restraint (bellows movement guided on two planes). Angular expansion joints with connecting pipe are used to compensate large movements.

Fixed points: Only light fixed points are required to absorb angular movement force and friction force.

RUBBER EXPANSION JOINTS

GENERAL DESCRIPTION OF RUBBER EXPANSION JOINTS (RUBBER BELLOWS)

MATERIAL QUALITIES

STENFLEX® rubber bellows are made of elastic synthetic elastomers. Their wide range of industrial applications are covered with combinations of the four standard elastomer qualities EPDM, CIIR, NBR and CR together with tensile reinforcing elements.

Elastomers are basic materials that are processed by adding sulphur, fillers, plasticizers and aging protection agents to produce rubber compounds suitable for vulcanization. Under the influence of temperature and pressure the vulcanization process (cross linkage) converts the rubber compounds into rubber grades – with their typical elastic properties.

Material properties such as hardness, elasticity, tensile strength, temperature resistance, etc., are rated to the corresponding application. Documents detailing media resistance of the rubber grades are available on request.



For different pressure and temperature requirements, different reinforcing materials (synthetic fibres or steel cord) are used in the intermediate layer of the rubber bellows. The rubber collar is self-sealing and additionally reinforced with wire cable cores for stability (protruding wire in the illustration).



The expansion joints are available in different rubber qualities to ensure the optimum solution for every application. The rubber quality can be recognised by the different colour markings. The additional embossing on the bellows serves to identify the nominal size and the product designation.

STRUCTURE

STENFLEX® rubber bellows have been optimized by calculation and verified by experimentation to produce highly elastic pressure-resistant bellows with flow contours to meet demanding absorption tasks.

Rubber bellows have a three-ply wall structure:

- inner ply (core) of medium-resistant rubber compound
- intermediate ply of rubber compound with tensile elements for reinforcement
- outer ply (cover layer) of weather-proof rubber compound

The arrangement of the tensile reinforcing elements is ascertained by calculation and experimentation to ensure that the force of pressure within the bellows can be absorbed. A permanent bond exists between the embedded tensile reinforcing elements and the rubber material.

The rubber grades used for the inner and outer ply are empirically defined rubber compounds rated to certain properties (media resistance, ozone resistance, UV resistance, elasticity, wear-proof characteristics, etc.)

Self sealing rubber rim

Rotatable flange with special profile

Stabilising collar: moulded on rim or welded collar

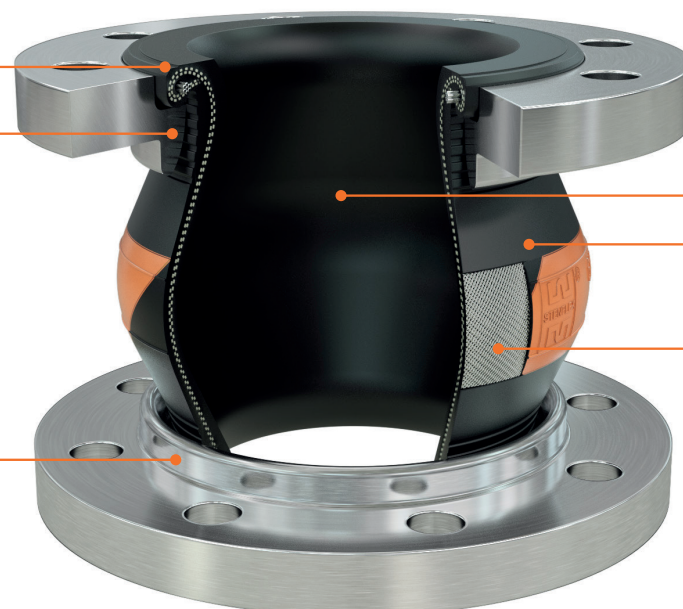

Inner layer (core) made of media-resistant rubber compound

Outer layer (top layer) of weather-resistant rubber compound

Intermediate layer of rubber coated synthetic fibre or steel cord reinforcement

RUBBER EXPANSION JOINTS

GENERAL DESCRIPTION OF RUBBER EXPANSION JOINTS (RUBBER BELLOWS)

STENFLEX® colour code	Properties	Applications
Rubber grade: EPDM Ethylene propylene diene rubber Trade name: Buna AP Keltan Vistaton		
orange	Heat- and weather-proof rubber grade with special resistance to highly oxidizing media and very many chemicals (not oil-resistant). Temperature resistance in continuous operation* from -40 °C to +100 °C. Resistant to hot water up to +100 °C.	Water, hot water, cooling water, sea water, steam, acids, lyes, pickling lyes, hypochlorite solutions etc. Special type AS in heating systems (as per DIN 4809 up to +110 °C)
Rubber grade: CIIR Chloro isobutylene isoprene rubber Trade name: Butyl		
white	Rubber grade complying with the latest hygiene directives for drinking water systems as per KTW recommendation by the German Health Department (KTW = Plastics for drinking water). Impermeable to gas. Temperature resistance in continuous operation* -40 °C to +90 °C. Resistant to hot water up to +90 °C.	Recommended for drinking water supply systems
Rubber grade: NBR Nitril-butadiene rubber Trade name: Perbunan		
red	Quality with excellent oil resistance, very resistant to swelling, e.g. even in contact with petrol/benzole mixture, impermeable to gas for hydrocarbons. Temperature resistance in continuous operation* -30 °C to +100 °C, resistant to hot water up to +70 °C.	Fuel oil, mineral oil, blast furnace waste gas, compressed air systems, cooling water with antifreezing compound
Rubber grade: CR Polychloroprene rubber Trade name: Neoprene Baypren		
-	Multi-purpose rubber grade with good oil, weather and flame resistance, very good resistance to ageing. Resistant to various organic and inorganic chemicals. Impermeable to gas for hydrocarbons. Temperature resistance in continuous operation* from -30 °C to +100 °C, resistant to hot water up to +70 °C.	Weather-proof outer ply (cover layer)

*The given temperature for continuous operation refers solely to the rubber grade. When reinforcements or other filling material is embedded, the temperature resistance in continuous operation increases.

RUBBER EXPANSION JOINTS

GENERAL DESCRIPTION OF RUBBER EXPANSION JOINTS (CONNECTION PARTS)

STENFLEX® rubber expansion joints are supplied ready for installation. They are connected to pipes, fittings, pumps, tanks etc., by flanges or screwed union. The connections are standardized to fit commercially available pipes, flanges and threads.

FLANGES

Flanges for rubber expansion joints in the series A, AR, AS, B, E, G, GR-SAE, MS, R and RS have a specially machined groove designed to accommodate the rubber rim. They are fitted in a rotating position at the bellows to simplify mounting to the pipeline.

STENFLEX® rubber expansion joints in the series C, D, and W have press-on retaining flanges.

The flanges have a stabilizing collar on the side facing the bellows (moulded on rim or welded collar). This stabilizes the rubber bellows and ensures compliance with safety spacing between the ends of the screws and the rubber bellows throughout the entire range of pressure and movement. The purpose is to eliminate the risk of damage to the rubber bellows caused by the screw ends. Special flanges are fitted with stabilizer rings.

Standard screws can be used because the flanges are drilled for through-bolts according to EN 1092 (DIN 2501). Other pitch circles and bores are possible e.g. to ANSI (ASA), BS, SAE and for ventilation systems.

Flanges vary according to expansion joint type (universal, lateral and angular expansion joints) and size as follows:

- Standard flanges
- Flanges with molded ears
- Flanges with welded ears
- Oval flanges
- Flanges with two pitch circles
- Flanges made to other standards

Standard flanges for rubber expansion joints are machined to produce a fit within the tolerances.

The following special versions are possible on request:

- All-round machined flanges
- Special materials deviating from the standard data sheet (stainless steels, aluminum, etc.)

Flanges made of unalloyed steels are galvanized and blue chromated or given an anti-corrosion prime coating. Stainless steel is used to meet tougher corrosion protection requirements. Other materials and forms of corrosion protection (hot-dip galvanizing, special varnish, coating etc.) can be supplied on request.

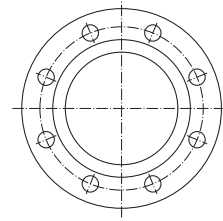

Standard flange with machined groove for rubber rim and stabilizing collar (universal expansion joint)

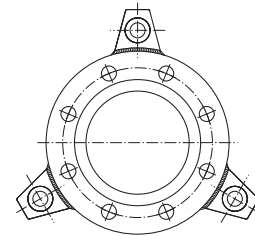

Flange with welded ears or molded ears for the restraints (lateral expansion joints)

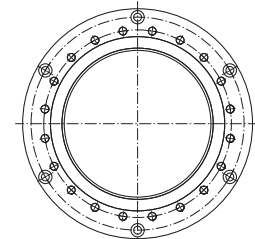

Flange with second pitch circle for the restraints (lateral expansion joints)

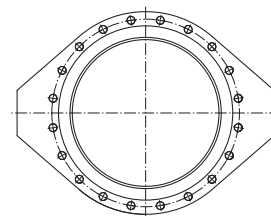

Oval flange (angular expansion joints)

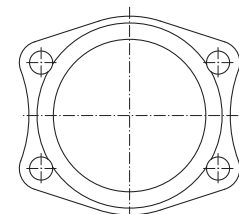

Flange as per SAE standard (Type GR-SAE)

Flange material	Material No. as per DIN EN	Abbreviation as per DIN EN (DIN)
Unalloyed steel	1.0038	S235JR
	1.0577	S355J2
Stainless steel	1.4541	X6CrNiTi18-10
	1.4571	X6CrNiMoTi17-12-2
	1.4404	X2CrNiMo17-12-2

RUBBER EXPANSION JOINTS

GENERAL DESCRIPTION OF RUBBER EXPANSION JOINTS

THREADED CONNECTIONS

Threaded connections are primarily used in domestic industry. Rubber expansion joints type AG-5 and AS-5 are equipped with female thread and flat seal in accordance with ISO 228-1, or with female or male thread (thread sealing) in accordance with ISO 7-1 (DIN 2999).

The threaded connections for type AS-5 are made of galvanized annealed cast iron. Stainless steel connection parts are used to meet increased anti-corrosion requirements (type AG-5). These are also suitable for pipes made of copper or plastic.

Material threaded part	Material No. as per DIN EN	Abbreviation as per DIN EN (DIN)
Unalloyed steel	1.0038	S235JR
Stainless steel	1.4571	X6CrNiMoTi17-12-2

TIE ROD RESTRAINTS

There are two types of tie rod restraints for lateral rubber expansion joints:

- External restraints to absorb reaction force from internal pressure (e.g. type A-2, AR-2, AS-2, B-2, R-2)
- External and internal restraints to absorb reaction force from internal pressure and vacuum (e.g. type A-4, AR-4, AS-4, B-4).

The tie rods in the flange ears for the lateral movement are carried

- by sound damping rubber sockets up to DN 150
- by spherical washers and conical seats as from DN 175

The tie rods, spherical washers and conical seats are galvanized and blue chromated. Stainless steel can be used for restraint elements to satisfy increased corrosion protection requirement. Other anti-corrosion coatings (hot-dip galvanizing, special varnish, coating) are available on request.

Material tie rod restraintg	Material No. as per DIN EN	Abbreviation as per DIN EN (DIN) or strength class
Unalloyed steel		
Tie rods	-	8.8
Washers	-	8.8
Stainless steel		
Tie rods, Washers	A2, 1.4057 A4, 1.4057	50, 70, C3-80 50, 70, C3-80

RESTRAINTS

Restraints are used for lateral and angular expansion joints. The restraints absorb the axial reaction force produced by internal pressure. Even so, the connected pipe must be equipped with light fixed points to absorb momentum force. The precise rating and operating parameters of the corresponding machinery or equipment must be known to calculate the degree of restrain correctly. Standard restraints are available for the lateral and angular expansion joint program. They are calculated on the basis of the material strength values at +50 °C. Reduced strength values are taken into consideration at higher temperatures.

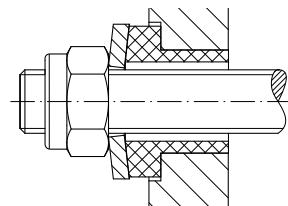

Sound damping external restraint (lateral expansion joint)

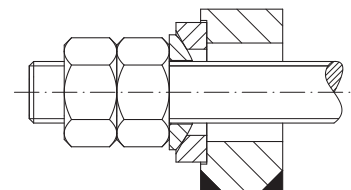

External restraint with spherical washer and conical seat (lateral expansion joint)

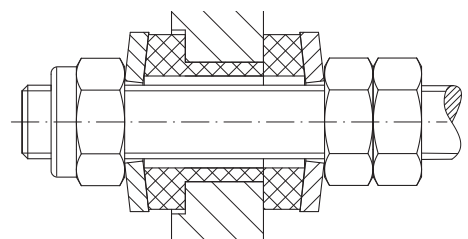

Sound damping external and internal restraint (lateral expansion joint)

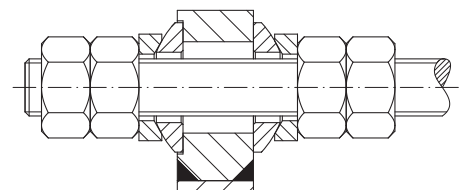

External and internal restraint with spherical washer and conical seat (lateral expansion joint)

RUBBER EXPANSION JOINTS

GENERAL DESCRIPTION OF RUBBER EXPANSION JOINTS

HINGE RESTRAINTS

Angular rubber expansion joints are equipped with oval flanges and welded hinge restraints that consist of joint bars and bolts.

The hinge restraints of unalloyed steel are coated with anti-corrosion primer. Stainless steel parts are used to satisfy tougher corrosion protection requirements. Other materials and forms of corrosion protection (hot-dip galvanizing, special varnish, coating, etc.,) are available on request.

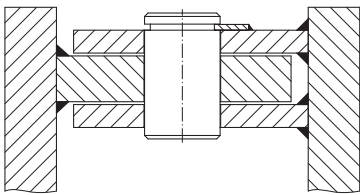

Restraint with welded joint bars and bolts (angular expansion joint)

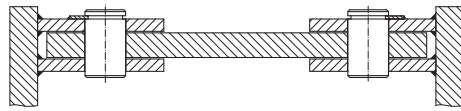

Double hinge restraint with welded straps and bolts (lateral expansion joint)

Material hinge restraint	Material No. as per DIN EN	Abbreviation as per DIN EN (DIN)
Unalloyed steel	1.0038	S235JR
	1.0577	S355J2
Stainless steel	1.4541	X6CrNiTi18-10
	1.4571	X6CrNiMoTi17-12-2

ACCESSORIES

STENFLEX® rubber expansion joints can be equipped with vacuum supporting rings, internal guide sleeves, outer protective covers, protective hoods or protective tubes.

VACUUM SUPPORTING RINGS

Depending on diameter and type, STENFLEX® rubber expansion joints are used for light to medium negative pressure. Vacuum supporting rings are fitted to the inner surface of the bellows convolutions for greater negative pressures (vacuum).

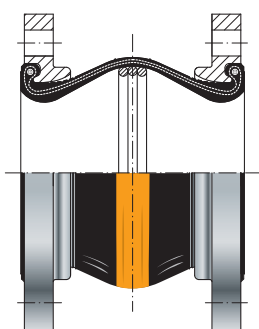

Rubber expansion joint with vacuum supporting ring

As a rule, the supporting rings are made of stainless steel up to DN400, for DN450 and larger, rubber-covered steel rings are used.

GUIDE SLEEVES

Normally internal guide sleeves are not required to reduce flow resistance because STENFLEX® rubber expansion joints have a streamlined inner surface with large transition radii (flow lines).

However, abrasive media or high flow velocities (see diagram) with high-frequency vibrations or turbulence (e.g. behind a pump) require that internal guide sleeves are installed to protect the rubber structure.

As a rule, the internal guide sleeves are made of stainless steel and are fitted with a flared flange. This seals the internal guide sleeve on the one side directly to the sealing face of the rubber bellows; on the other side of the flared flange an additional seal must be used against the counter flange.

In the case of purely axial movement, cylindrical guide sleeves are used. For lateral and/or angular movement, conical internal guide sleeves are fitted (tapering cross section).

Telescopic internal guide sleeves are only used in special cases.

Being aware of the flow direction is very important when installing expansion joints with internal guide sleeves.

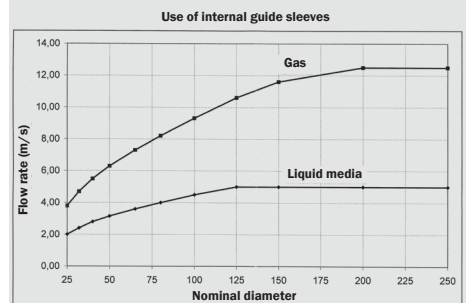

For flow rates, above the curve, it is advisable to install internal guide sleeves to protect the bellows. The data are of indicative nature.

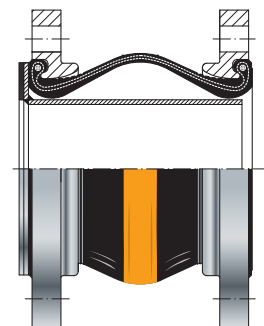

Rubber expansion joint with cylindrical internal guide sleeve and additional soft seal to the counter flange.



RUBBER EXPANSION JOINTS

COMPENSATION SYSTEMS

For over 50 years now, customers working in the field of industrial pipeline construction around the world have relied on flexible pipe connections from STENFLEX® – the specialist for high-quality construction elements.

STENFLEX® compensation pipe pieces can be supplied on request as complete system solution with ready mounted expansion joints. As a rule, these are angular and lateral expansion joints, designed according to customer requirements. Pipe sections, bends, T-pieces and expansion joints are put together with the necessary restraints, hinges, protective covers etc., to form a unit.

Our experts assist in the selection and optimum arrangement of the system components to produce a compensation system ready to be installed.

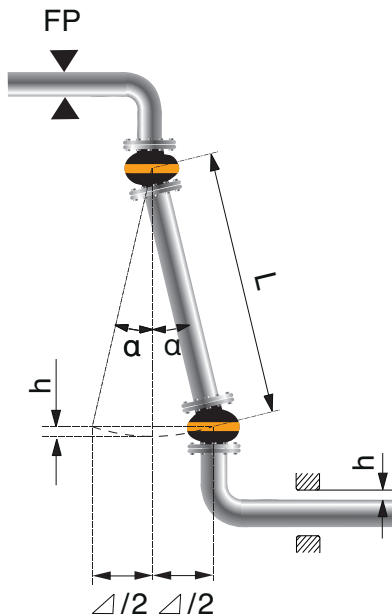

Installation with 50 % pre-tension

Expansion absorption Δ depends on the centre-to-centre spacing L of the expansion joints and the maximum deflection angle α . It is calculated according to the following formula:

$$L = \frac{\Delta/2}{\sin \alpha} \quad \Delta/2 = L \cdot \sin \alpha$$

The deflecting pipeline must have sufficient play in the guide bearing to allow for the radian measure. It is calculated as follows:

$$h = L (1 - \cos \alpha)$$

COMPENSATION SYSTEMS WITH ANGULAR EXPANSION JOINTS

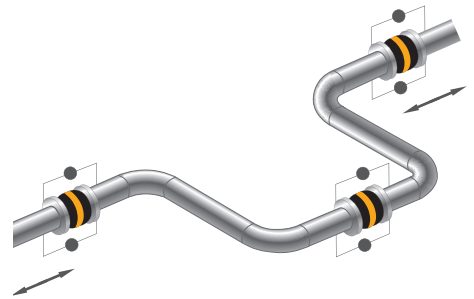

U-shaped triple joint, 3 angular expansion joints

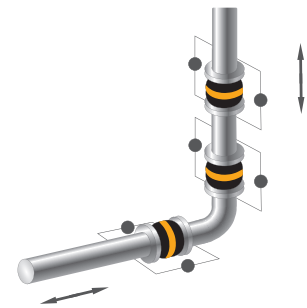

L-shaped triple joint, 3 angular expansion joints

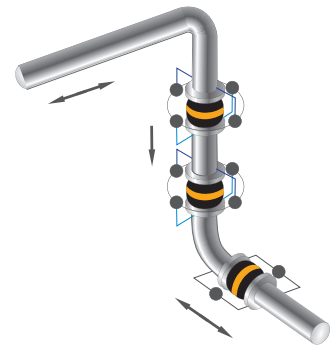

3D triple joint, 2 cardan hinged restraint expansion joints, 1 angular expansion joint

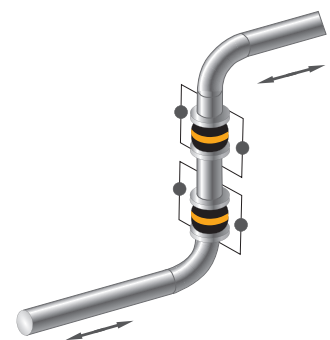



Z-shaped double joint, 2 angular expansion joints

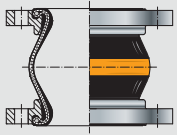
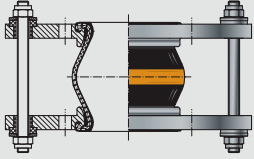
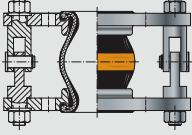
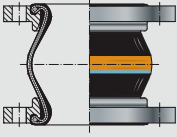
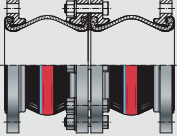
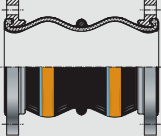
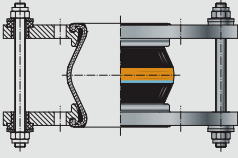
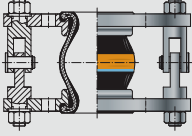
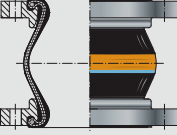

RUBBER EXPANSION JOINTS

PROGRAM SUMMARY

	Type	DN	Pressure rate bar	Max. operating temperature*	Rubber grades	Connection parts	Page
	A-1	DN 20 - 1000	PN 16	+90 °C	EPDM, NBR, CIIR	rotatable flanges	30
	A-2 A-4	DN 20 - 1000	PN 16	+90 °C	EPDM, NBR, CIIR	rotatable flange with tie rod restraint	32
	A-3	DN 32 - 1000	PN 16	+90 °C	EPDM, NBR, CIIR	rotatable flange with hinge restraint	34
	AS-1	DN 25 - 400	PN 16	+110 °C	EPDM, NBR	rotatable flanges	36
	AS-1D	DN 25 - 250	PN 16	+110 °C	EPDM, NBR	rotatable flanges	38
	MS-1	DN 65 - 250	PN 16	+110 °C	EPDM, NBR	rotatable flanges	40
	AS-2 AS-4	DN 25 - 400	PN 16	+110 °C	EPDM, NBR	rotatable flange with tie rod restraint	42
	AS-3	DN 25 - 400	PN 16	+110 °C	EPDM, NBR	rotatable flange with hinge restraint	44
	VS-1	DN 40 - 150	PN 16	+110 °C	EPDM, NBR	rotatable flanges	46
	AR-1	DN 20 - 600	PN 25	+110 °C	EPDM, NBR	rotatable flanges	48

*Consideration of pressure reduction at maximum temperatures, see technical annex page 198

RUBBER EXPANSION JOINTS



PROGRAM SUMMARY

	Type	DN	Pressure rate bar	Max. operating temperature*	Rubber grades	Connection parts	Page
	AR-2 AR-4	DN 20 – 600	PN 25	+110 °C	EPDM, NBR	rotable flange with tie rod restraint	50
	R-1	DN 25 – 300	PN 16	+90 °C	EPDM, NBR, CIIR	rotable flanges	52
	R-2	DN 25 – 300	PN 16	+90 °C	EPDM, NBR, CIIR	rotable flange with tie rod restraint	54
	GR-SAE	DN 40 – 125	PN 16	+110 °C	NBR	rotable SAE-flange	56
	RS-1	DN 25 – 300	PN 16	+90 °C	EPDM, NBR	rotable flanges	58
	RS-2	DN 25 – 300	PN 16	+90 °C	EPDM, NBR	rotable flange with tie rod restraint	60
	B-1	DN 32 – 400	PN 16	+90 °C	EPDM, NBR	rotable flanges	62
	B-2 B-4	DN 32 – 400	PN 16	+90 °C	EPDM, NBR	rotable flange with tie rod restraint	64
	AG-5	DN 20 – 50	PN 16	+100 °C	EPDM, NBR, CIIR	female and/or male thread	66
	AS-5	DN 32 – 40	PN 16	+110 °C	EPDM, NBR	female and/or male thread	67

*Consideration of pressure reduction at maximum temperatures, see technical annex page 198

RUBBER EXPANSION JOINTS

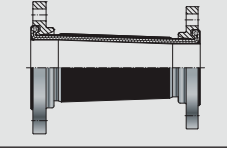
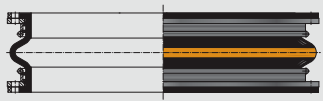
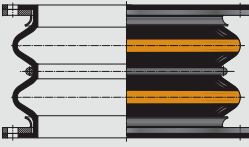
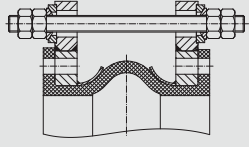
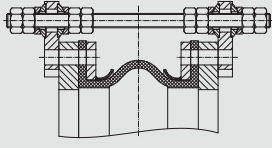
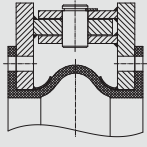
PROGRAM SUMMARY

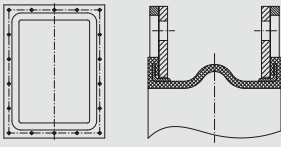
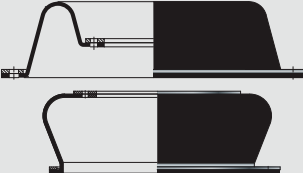
	Type	DN	Pressure rate bar	Max. operating temperature*	Rubber grades	Connection parts	Page
	E	DN 20 – 250	PN 10	+90 °C	EPDM, NBR	rotatable flanges	68
	G	DN 25 – 100 DN 125 – 250	PN 16 PN 10	+90 °C	EPDM, NBR	rotatable flanges	70
	C-1	DN 300 – 2400 DN 300 – 2800 DN 300 – 3600	PN 16 PN 10 PN 4	+90 °C	EPDM, NBR, CIIR	press-on retaining flange	72
	C-2	DN 300 – 2000 DN 300 – 2000	PN 10 PN 4	+90 °C	EPDM, NBR, CIIR	press-on retaining flange	74
	C-31	DN 300 – 1000 DN 300 – 1000 DN 300 – 2400 DN 2500 – 3600	PN 16 PN 10 PN 4	+90 °C +90 °C +90 °C	EPDM, NBR, CIIR	press-on retaining flange with tie rod restraint	76
	C-35	DN 300 – 3600	on request	+90 °C	EPDM, NBR, CIIR	press-on retaining flange with tie rod restraint on segments	78
	C-41	DN 300 – 3600	on request	+90 °C	EPDM, NBR, CIIR	press-on retaining flange with hinge restraint	79
	D-11 D-30	DN 300 – 7500 DN 300 – 7500	PN 0,7	+90 °C	EPDM, NBR	rotatable press-on retaining flange or tightening straps	80
	D-21 D-22 D-41 D-42	DN 150 – 7500 DN 150 – 7500 DN 150 – 7500 DN 150 – 7500	PN 0,7	+90 °C	EPDM, NBR	press-on retaining frame	82
	W-1 W-2	DN 80 – 3400 DN 200 – 800	PN 2,5	+110 °C	EPDM, NBR	press-on retaining flange	84

*Consideration of pressure reduction at maximum temperatures, see technical annex page 198

RUBBER EXPANSION JOINT TYPE A-1

UNIVERSAL EXPANSION JOINT DN 20 – DN 1000

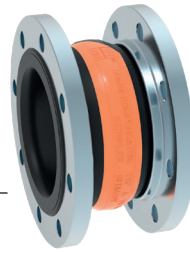

STRUCTURE TYPE A-1 / RUBBER BELLOWS PN 16

- Universal expansion joint, consisting of a rubber bellows with rotatable flanges
- Highly elastic molded bellows in various rubber grades
- Synthetic fibre reinforcement
- Wire-reinforced self-sealing rubber rim
- Electrical impedance 10^3 to 10^6 Ohm (DIN IEC 93, VDE 0303-30)

Rubber grade*	EPDM	NBR	CIIR
Colour code	orange	red	white
Possible uses	Hot water, acids, lyes	hydrocarbon containing liquids	Drinking water

*Check or inquire about the resistance of the rubber grade to temperature and medium

Technical design	
Max. perm. operating pressure	16 bar*
Max. perm. temperature	+100 °C
Bursting pressure	≥ 48 bar
Vacuum operation	DN 20 – 50 without vacuum supporting ring, DN 65 – 1000 with vacuum supporting ring

Max. operating pressure to be set 30 % lower for shock loads.

*Please consider a decrease of pressure due to temperature (see technical annex).

FLANGES / VERSIONS

- Rotatable flanges with stabilizing collar
- Flange drilling for through bolts
- Special machined groove for rubber rim

	Standard		Others
Dimensions	EN 1092		ANSI, BS etc. Connection dimensions see technical annex page 213 – 215
Materials	1.0038 (S235JR)		1.4571
Corrosion protection	DN 20 – DN 400 electro-galvanized	DN 450 – DN 1000 hot-dip galvanized	special coating, etc.

NOTE

Please comply with the general technical instructions regarding reaction force, moving force, fixed point load, installation instructions etc.

Subject to technical alterations and deviations resulting from the manufacturing process.

APPLICATIONS

- for reducing thermal and mechanical tension in pipes and their system components, e.g.
 - pumps
 - compressors
 - engines
- for absorbing vibration and noise
- for compensating axial, lateral and angular movement
- for compensating simultaneous movement in cooling water pipes
- to compensate for installation inaccuracies
- as installation and dismantling aid

CERTIFICATES

- CE (PED 2014/68/EU)
- DNV GL® / DNV®
- Lloyd's Register of Shipping
- Drinking water
- TÜV Süd (KTA)
- Bureau Veritas
- Others see technical annex

ACCESSORIES

- Vacuum supporting ring
- Internal guide sleeve
- Flame-proof protective cover
- Protective hood
- Protective tube

DIMENSIONS STANDARD PROGRAM

DN	BL*	Pressure rate bar	Ø di Bellows inner Ø mm	Ø C Raised face outer Ø mm	Ø E Raised face inner Ø mm	Ø W** Convolution Ø mm	PN Flange connection EN 1092	Ø D Flange outer Ø mm	b Flange thickness mm
20	100	16	22 ± 3	51	30	55	16	115	16
25	100	16	22 ± 3	51	30	55	16	115	16
32	125	16	31 ± 3	72	39	78	16	140	16
32	150	16	31 ± 3	72	39	88	16	140	16
40	125	16	39 ± 3	81	45	86	16	150	16
40	150	16	39 ± 3	81	45	96	16	150	16
50	125	16	49 ± 3	95	56	97	16	165	16
50	150	16	49 ± 3	95	56	107	16	165	16
65	125	16	65 ± 3	115	72	113	16	185	18
65	150	16	65 ± 3	115	72	123	16	185	18
80	150	16	77 ± 3	127	84	135	16	200	20
100	150	16	100 ± 3	151	109	160	16	220	20
125	150	16	127 ± 3	178	133	184	16	250	22
150	150	16	153 ± 3	206	161	212	16	285	22
175	150	16	176 ± 3	230	185	236	16	315	22
200	150	10	202 ± 3	260	209	265	10	340	25
200	175	10	202 ± 3	260	209	265	10	340	25
250	175	10	252 ± 3	313	262	318	10	395	25
250	200	10	252 ± 3	313	262	318	10	395	25
300	200	10	303 ± 3	363	312	373	10	445	25
350	200	10	344 ± 3	423	360	420	10	505	30
400	200	10	396 ± 3	474	410	460	10	565	30
450	250	10	435 ± 8	532	450	575	10	615	35
500	250	10	485 ± 8	584	500	625	10	670	35
600	250	10	585 ± 8	684	600	725	10	780	40
700	275	10	690 ± 10	800	700	850	10	895	40
800	275	10	790 ± 10	900	800	950	10	1015	40
900	300	10	890 ± 10	1008	900	1050	10	1115	40
1000	300	10	990 ± 10	1108	1000	1150	10	1230	40

*DN 25 to DN 300 also available in BL 130 mm as Type R-1. **unpressurized. From DN 200 also available with pressure rate 16 bar. Please contact us for further flange dimensions.

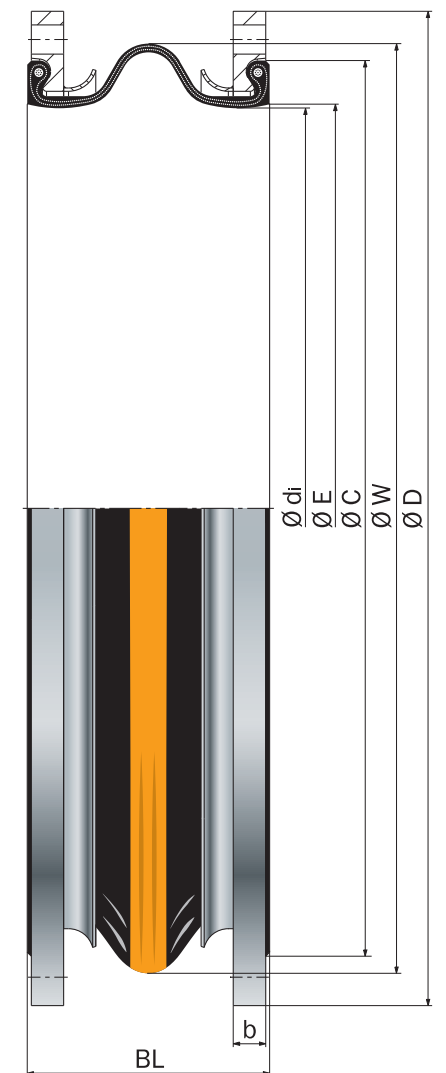
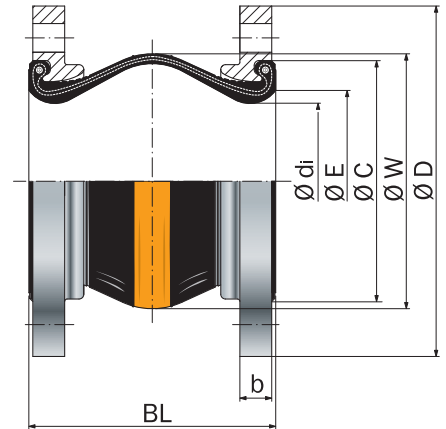

MOVEMENT COMPENSATION

DN	BL mm	Δ ax Axial movement		Δ lat Lateral movement ± mm	Δ ang* Angular movement ± < degrees	A** Effective bellows cross sectional area at 16 bar cm²	Permissible vacuum w/o supporting ring at length BL bar absolute	Weight approx. kg
		Compression - mm	Elongation + mm					
20	100	20	10	10	25	0	-	2.3
25	100	20	10	10	25	0	-	2.3
32	125	35	10	15	25	1	0.6	3.3
32	150	35	20	20	25	0	0.5	3.4
40	125	35	10	15	25	6	0.6	3.7
40	150	35	20	20	25	1	0.5	3.8
50	125	35	10	15	25	12	0.6	4.4
50	150	35	20	20	25	13	0.5	4.5
65	125	35	10	15	25	23	0.6	5.2
65	150	35	20	20	20	30	0.7	5.3
80	150	40	10	15	20	42	0.65	7.2
100	150	40	10	15	15	68	0.65	8.0
125	150	40	10	15	15	92	0.7	10.7
150	150	40	10	15	12	173	0.75	13.0
175	150	40	10	15	10	247	0.8	15.6
200	150	20	30	15	8	435	0.9	18.4
200	175	45	15	15	8	264	0.9	18.6
250	175	45	15	15	7	503	0.9	24.2
250	200	35	35	15	6	545	0.9	24.3
300	200	45	15	15	6	550	0.9	30.2
350	200	45	15	15	5	990	0.95	40.1
400	200	45	15	15	5	1100	0.95	48.8
450	250	50	30	30	8	1706	0.35	64.0
500	250	50	30	30	7	2013	0.35	72.0
600	250	50	30	30	6	3006	0.35	90.0
700	275	50	30	30	5	4250	0.5	120.0
800	275	50	30	30	5	5440	0.5	155.0
900	300	50	30	30	4	7000	0.6	170.0
1000	300	50	30	30	3.5	8544	0.6	205.0

Type A-1

Universal expansion joint, without restraint

*Larger Δ D ang possible for compressed installation length.

**Effective bellows cross sectional area is a theoretical value.

Please inquire for simultaneous (different) movement.

RUBBER EXPANSION JOINT TYPE A-2, A-4

LATERAL EXPANSION JOINT DN 20 – DN 1000

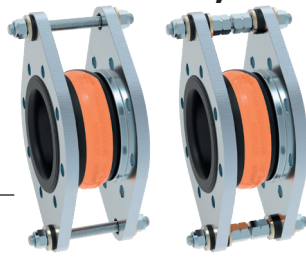

STRUCTURE TYPE A-2, A-4 / RUBBER BELLOWS PN 16

- **Type A-2:** Lateral expansion joint consisting of a rubber bellows with rotatable flanges and tie rods (external restraints) to absorb reaction force from internal pressure
- **Type A-4:** Lateral expansion joint consisting of a rubber bellows with rotatable flanges and tie rods (external and internal restraints) to absorb reaction force from internal pressure or vacuum
- Highly elastic molded bellows in various rubber grades
- Synthetic fibre reinforcement
- Wire-reinforced self-sealing rubber rim
- Electrical impedance 10^3 to 10^6 Ohm (DIN IEC 93, VDE 0303-30)

Rubber grade*	EPDM	NBR	CIIR
Colour code	orange	red	white
Possible uses	Hot water, acids, lyes	hydrocarbon containing liquids	Drinking water

*Check or inquire about the resistance of the rubber grade to temperature and medium

Technical design	
Max. perm. operating pressure	16 bar*
Max. perm. temperature	+100 °C
Bursting pressure	≥ 48 bar
Vacuum operation	DN 20 – 50 without vacuum supporting ring, DN 65 – 1000 with vacuum supporting ring

Max. operating pressure to be set 30 % lower for shock loads.

*Please consider a decrease of pressure due to temperature (see technical annex).

FLANGES / VERSIONS

- Flanges with stabilizing collar and ears to carry the tie rods
- Flange drilling for through bolts
- Special machined groove for rubber rim

	Standard		Others
Dimensions	EN 1092		ANSI, BS etc. Connection dimensions see technical annex page 213 – 215
Materials	1.0038 (S235JR)		1.4571
Corrosion protection	DN 20 – DN 400 electro-galvanized	DN 450 – DN 1000 hot-dip galvanized	special varnish, special coating, etc.

NOTE

Please comply with the general technical instructions regarding reaction force, moving force, fixed point load, installation instructions etc.

Subject to technical alterations and deviations resulting from the manufacturing process.

APPLICATIONS

- for reducing thermal and mechanical tension in pipes and their system components, e.g.
 - pumps
 - compressors
 - engines
- for muffling vibration and noise
- for compensating lateral movement
- to compensate for installation inaccuracies
- to compensate for ground and foundation settlement or tank settlement during filling

TIE ROD RESTRAINTS

- DN 20 – DN 150 Tie rods carried on silencing rubber sockets
- DN 175 – DN 1000 Tie rods carried on spherical washers and conical seats

Materials

Standard: tie rods 8.8

Others: stainless steel

Corrosion protection

Standard: electrogalvanized

Others: hot-dip galvanized

CERTIFICATES

- CE (PED 2014/68/EU)
- Bureau Veritas
- DNV GL® / DNV®
- Lloyd's Register of Shipping
- Drinking water
- TÜV Süd (KTA)
- Others see technical annex

DIMENSIONS STANDARD PROGRAM

DN	BL*	Pressure rate bar	Ø dj Bellows inner Ø mm	Ø C Raised face outer Ø mm	Ø E Raised face inner Ø mm	Ø W** Convolution Ø mm	PN Flange connection EN 1092	Ø D Flange outer Ø mm	b Flange thickness mm	H Flange height mm
20	100	16	22 ± 3	51	30	55	16	115	16	195
25	100	16	22 ± 3	51	30	55	16	115	16	195
32	125	16	31 ± 3	72	39	78	16	140	16	220
32	150	16	31 ± 3	72	39	88	16	140	16	220
40	125	16	39 ± 3	81	45	86	16	150	16	230
40	150	16	39 ± 3	81	45	96	16	150	16	230
50	125	16	49 ± 3	95	56	97	16	165	16	240
50	150	16	49 ± 3	95	56	107	16	165	16	240
65	125	16	65 ± 3	115	72	113	16	185	18	260
65	150	16	65 ± 3	115	72	123	16	185	18	260
80	150	16	77 ± 3	127	84	135	16	200	20	300
100	150	16	100 ± 3	151	109	160	16	220	20	350
125	150	16	127 ± 3	178	133	184	16	250	22	385
150	150	16	153 ± 3	206	161	212	16	285	22	420
175	150	16	176 ± 3	230	185	236	16	315	22	440
200	150	10	202 ± 3	260	209	265	10	340	25	465
200	175	10	202 ± 3	260	209	265	10	340	25	465
250	175	10	252 ± 3	313	262	318	10	395	25	520
250	200	10	252 ± 3	313	262	318	10	395	25	520
300	200	10	303 ± 3	363	312	373	10	445	25	570
350	200	10	344 ± 3	423	360	420	10	505	30	630
400	200	10	396 ± 3	474	410	460	10	565	30	690
450	250	10	435 ± 8	532	450	575	10	615	35	795
500	250	10	485 ± 8	584	500	625	10	670	35	850
600	250	10	585 ± 8	684	600	725	10	780	40	960
700	275	6	690 ± 10	800	700	850	10	895	40	1075
800	275	6	790 ± 10	900	800	950	10	1015	40	1195
900	300	4	890 ± 10	1008	900	1050	10	1115	40	1295
1000	300	4	990 ± 10	1108	1000	1150	10	1230	40	1410

*DN 32 to DN 300 also available in BL 130 mm as Type R-2. **unpressurized. From DN 200 higher pressure rate available on request. Please contact us for further flange dimensions.

MOVEMENT COMPENSATION / FLANGE VERSIONS

DN	BL	Δ lat Lateral movement ± mm	Permissible vacuum w/o supporting ring at length BL bar absolute	Weight type A-2 approx. kg
20	100	10	-	3.9
25	100	10	-	3.9
32	125	15	0.6	5.1
32	150	20	0.5	5.2
40	125	15	0.6	5.6
40	150	20	0.5	5.7
50	125	15	0.6	6.3
50	150	20	0.5	6.4
65	125	15	0.6	8.0
65	150	20	0.7	8.1
80	150	15	0.65	10.7
100	150	15	0.65	12.6
125	150	15	0.7	16.8
150	150	15	0.75	19.6
175	150	15	0.8	19.9
200	150	15	0.9	22.5
200	175	15	0.9	22.7
250	175	15	0.9	27.5
250	200	15	0.9	27.6
300	200	15	0.9	31.6
350	200	15	0.95	46.7
400	200	15	0.95	57.8
450	250	30	0.35	85.7
500	250	30	0.35	98.0
600	250	30	0.35	133.9
700	275	30	0.5	173.5
800	275	30	0.5	213.6
900	300	30	0.6	250.0
1000	300	30	0.6	295.5

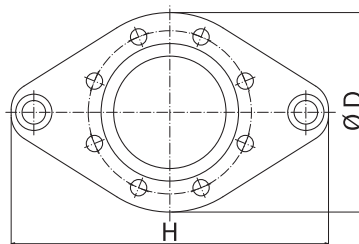

DN 20 - DN 150

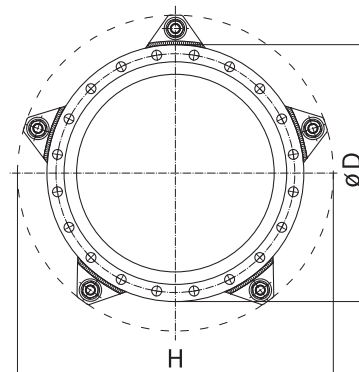

DN 175 - DN 1000

Number of tie rods depending on pressure

ACCESSORIES

- Vacuum supporting ring
- Internal guide sleeve
- Flame-proof protective cover
- Protective hood
- Protective tube

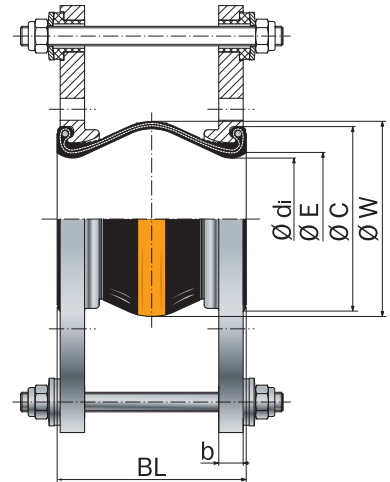

Type A-2

Tie rods, external restraints, carried on silencing rubber sockets

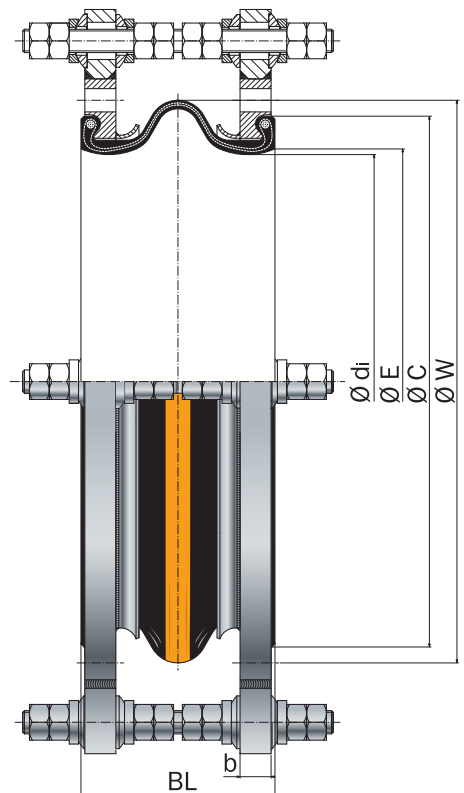

Type A-4

Design as type A-2, additional internal restraints, carried on spherical washers and conical seats

RUBBER EXPANSION JOINT TYPE A-3

ANGULAR EXPANSION JOINT DN 32 – DN 1000

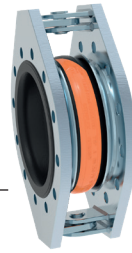

STRUCTURE TYPE A-3 / RUBBER BELLOWS PN 16

- Angular expansion joint consisting of a rubber bellows and flanges
- Welded hinge restraints to absorb reaction force from internal pressure or vacuum
- Highly elastic molded bellows in various rubber grades
- Synthetic fibre reinforcement
- Wire-reinforced self-sealing rubber rim
- Electrical impedance 10^3 to 10^6 Ohm (DIN IEC 93, VDE 0303-30)

Rubber grade*	EPDM	NBR	CIIR
Colour code	orange	red	white
Possible uses	Hot water, acids, lyes	hydrocarbon containing liquids	Drinking water

*Check or inquire about the resistance of the rubber grade to temperature and medium

Technical design	
Max. perm. operating pressure	16 bar*
Max. perm. temperature	+100 °C
Bursting pressure	≥ 48 bar
Vacuum operation	DN 32 – 50 without vacuum supporting ring, DN 65 – 1000 with vacuum supporting ring

Max. operating pressure to be set 30 % lower for shock loads.

*Please consider a decrease of pressure due to temperature (see technical annex).

FLANGES / VERSIONS

- Oval flanges with stabilizing collar and hinge restraints
- Flange drilling for through bolts
- Special machined groove for rubber rim

	Standard		Others
Dimensions	EN 1092		ANSI, BS etc. Connection dimensions see technical annex page 213 – 215
Materials	1.0038 (S235JR)		stainless steel, etc.
Corrosion protection	DN 32 – DN 175 electro-galvanized	DN 200 – DN 1000 anti-corrosion primed	hot-dip galvanized, special varnish, special coating, etc.

NOTE

Please comply with the general technical instructions regarding reaction force, moving force, fixed point load, installation instructions etc.

Subject to technical alterations and deviations resulting from the manufacturing process.

APPLICATIONS

- for compensating angular movement
- as double or triple joint compensation system for large movements
 - for ground and foundation settlement
 - for tank settlement during filling
- in plastic pipe systems
- apparatus engineering and tank construction
- power station technology

HINGE RESTRAINTS

- Pivot of joint bars at center of bellows
- Hinge restraints control bellows movement

Materials

Standard: 1.0038 (S235JR),
1.0577 (S355J2)

Others: stainless steel, etc.

Corrosion protection

Standard: DN 32 - DN 175 electrogalvanized
DN 200 - DN 1000 anti-corrosion primed

Others: hot-dip galvanized, special varnish and coating, etc

CERTIFICATES

- CE (PED 2014/68/EU)
- Bureau Veritas
- DNV GL® / DNV®
- Lloyd's Register of Shipping
- Drinking water
- TÜV Süd (KTA)
- Others see technical annex

DIMENSIONS STANDARD PROGRAM

DN	BL*	Pressure rate	Ø dj Bellows inner Ø	Ø C Raised face outer Ø	Ø E Raised face inner Ø	Ø W** Con- volution Ø	PN Flange connec- tion EN 1092	Ø D Flange outer Ø	b Flange thick- ness	H Flange height
	mm	bar	mm	mm	mm	mm		mm	mm	mm
32	125	16	31 ± 3	72	39	78	16	140	16	220
40	125	16	39 ± 3	81	45	86	16	150	16	230
50	125	16	49 ± 3	95	56	97	16	165	16	240
65	125	16	65 ± 3	115	72	113	16	185	18	260
80	150	16	77 ± 3	127	84	135	16	200	20	300
100	150	16	100 ± 3	151	109	160	16	220	20	350
125	150	16	127 ± 3	178	133	184	16	250	22	385
150	150	16	153 ± 3	206	161	212	16	285	22	420
175	150	16	176 ± 3	230	185	236	16	315	22	445
200	175	10	202 ± 3	260	209	265	10	340	25	470
250	175	10	252 ± 3	313	262	318	10	395	25	530
300	200	10	303 ± 3	363	312	373	10	445	25	550
350	200	10	344 ± 3	423	360	420	10	505	30	645
400	200	10	396 ± 3	474	410	460	10	565	30	740
450	250	10	435 ± 8	532	450	575	10	615	40	845
500	250	10	485 ± 8	584	500	625	10	670	40	895
600	250	10	585 ± 8	684	600	725	10	780	45	1020
700	275	6	690 ± 10	800	700	850	10	895	45	1140
800	275	6	790 ± 10	900	800	950	10	1015	45	1285
900	300	4	890 ± 10	1008	900	1050	10	1115	50	1385
1000	300	4	990 ± 10	1108	1000	1150	10	1230	55	1485

From DN 200 higher pressure rate available on request. Please contact us for further flange di- mensions. *The measure BL (length) for DN 400 - 1000 is approx. 6 mm shorter when fitted. **unpressurized

MOVEMENT COMPENSATION / FLANGE VERSIONS

DN	Δ ang Angular movement ± ∠ degrees	Weight approx. kg
32	25	6.0
40	25	6.5
50	25	7.2
65	25	8.6
80	20	12.1
100	15	14.0
125	15	17.6
150	12	20.4
175	10	23.1
200	8	34.5
250	7	39.6
300	6	45.2
350	5	70.0
400	5	95.0
450	8	155.0
500	7	190.0
600	6	250.0
700	5	290.0
800	5	360.0
900	4	425.0
1000	3.5	550.0

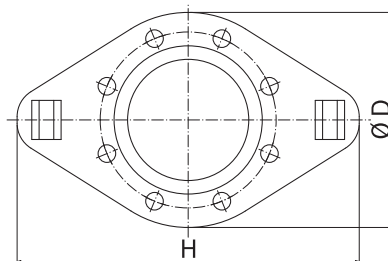

DN 32 - DN 150

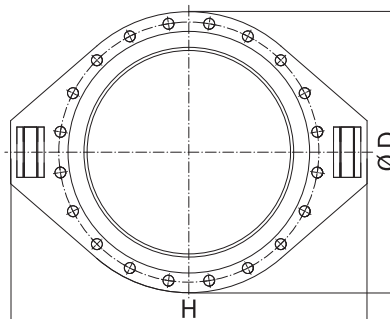

DN 175 - DN 1000

ACCESSORIES

- Vacuum supporting ring
- Internal guide sleeve
- Flame-proof protective cover
- Protective hood

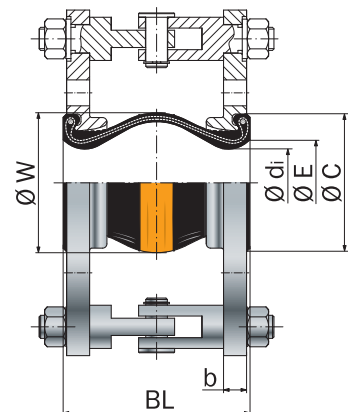

DN 32 - DN 150

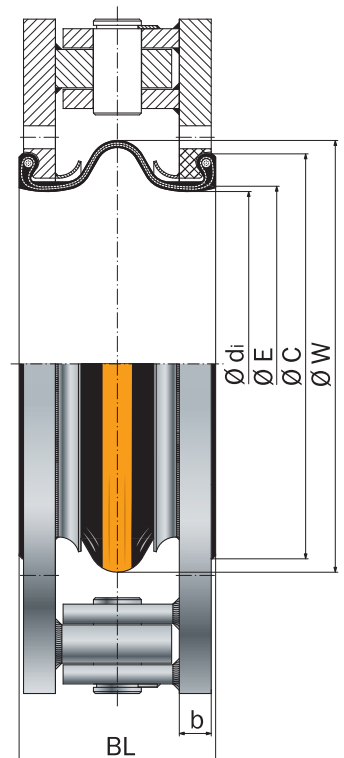

DN 175 - DN 1000

Type A-3

Angular expansion joint with hinge restraints

RUBBER EXPANSION JOINT TYPE AS-1

FLAME-PROOF

UNIVERSAL EXPANSION JOINT DN 25 – DN 400

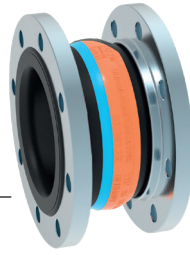

STRUCTURE TYPE AS-1 / RUBBER BELLOWS PN 16

- Universal expansion joint, consisting of a rubber bellows and rotatable flanges
- Highly elastic molded bellows in various rubber grades
- Steel wire cord reinforcement
- Wire-reinforced self-sealing rubber rim
- Electrical impedance < 100 Ohm (DIN IEC 93, VDE 0303-30)

Rubber grade*	EPDM	NBR
Colour code	orange/blue	red/blue
Possible uses	Hot water, acids, lyes	hydrocarbon containing liquids

*Check or inquire about the resistance of the rubber grade to temperature and medium.

Technical design	
Max. perm. operating pressure	16 bar*
Max. perm. temperature	+130 °C
Bursting pressure	≥ 50 bar
Vacuum operation	DN 25 – 50 without vacuum supporting ring, DN 65 – 400 with vacuum supporting ring

Max. operating pressure to be set 30 % lower for shock loads.

*Please consider a decrease of pressure due to temperature (see technical annex).

FLANGES / VERSIONS

- Rotatable flanges with stabilizing collar
- Flange drilling for through bolts, DN 25 with Drill holes
- Special machined groove for rubber rim

	Standard	Others
Dimensions	EN 1092	ANSI, BS etc. Connection dimensions see technical annex page 213 – 215
Materials	1.0038 (S235JR)	1.4541, 1.4571 etc.
Corrosion protection	electrogalvanized	hot-dip galvanized, special varnish, special coating, etc.

NOTE

Please comply with the general technical instructions regarding reaction force, moving force, fixed point load, installation instructions etc.

Subject to technical alterations and deviations resulting from the manufacturing process.

Chemicals used for water treatment (particularly in heating systems and coolant systems) can corrode the materials of the rubber expansion joint. According to VDI Directive 2035, DIN 4809 part 1 and VGB R 455P, the manufacturer of the chemicals must state that the materials used in the expansion joint, especially for the rubber bellows, will not be damaged by the chemicals.

APPLICATIONS

- for reducing thermal and mechanical tension in pipes and their system components, e.g.
 - pumps
 - compressors
 - engines
- for muffling vibration and noise
 - at appliances
 - in cooling water and lub oil pipes
- for compensating axial, lateral and angular movement
- to compensate for installation inaccuracies
- to meet fire protection regulations
- shipbuilding industry
- in heating plants

CERTIFICATES

- CE (PED 2014/68/EU)
- American Bureau of Shipping
- DNV GL® / DNV®
- Bureau Veritas
- Lloyd's Register of Shipping
- TÜV/DIN 4809 (DN 25 – 200)
- TÜV Süd (KTA)
- MED
- Others see technical annex

DIMENSIONS STANDARD PROGRAM

DN	BL*	Pressure rate	Ø dj Bellows inner Ø	Ø C Raised face outer Ø	Ø E Raised face inner Ø	Ø W*** Con- volution Ø	PN Flange connec- tion EN 1092	Ø D Flange outer Ø	b Flange thick- ness mm
	mm	bar	mm	mm	mm	mm		mm	mm
25	125	16	31 ± 3	72	39	78	16**	115	16
32	125	16	31 ± 3	72	39	78	16	140	16
32	150	16	31 ± 3	72	39	88	16	140	16
40	125	16	39 ± 3	81	45	86	16	150	16
40	150	16	39 ± 3	81	45	96	16	150	16
50	125	16	49 ± 3	95	56	97	16	165	16
50	150	16	49 ± 3	95	56	107	16	165	16
65	125	16	65 ± 3	115	72	113	16	185	18
65	150	16	65 ± 3	115	72	123	16	185	18
80	150	16	77 ± 3	127	84	135	16	200	20
100	150	16	100 ± 3	151	109	160	16	220	20
125	150	16	127 ± 3	178	133	184	16	250	22
150	150	16	153 ± 3	206	161	212	16	285	22
175	150	16	176 ± 3	230	185	236	16	315	22
200	150	10	202 ± 3	260	209	265	10	340	25
200	175	10	202 ± 3	260	209	265	10	340	25
250	175	10	252 ± 3	313	262	318	10	395	25
250	200	10	252 ± 3	313	262	318	10	395	25
300	200	10	303 ± 3	363	312	373	10	445	25
350	200	10	344 ± 3	423	360	420	10	505	30
400	200	10	396 ± 3	474	410	460	10	565	30

* DN 25 up to DN 300 also available as type RS-1 in length 130.

** Flanges with drill holes M 12.

*** unpressurized

From DN 200 pressure rate 16 bar also available with flanges PN 16. Please contact us for further flange dimensions.

ACCESSORIES

- Vacuum supporting ring
- Internal guide sleeve
- Protective hood
- Protective tube

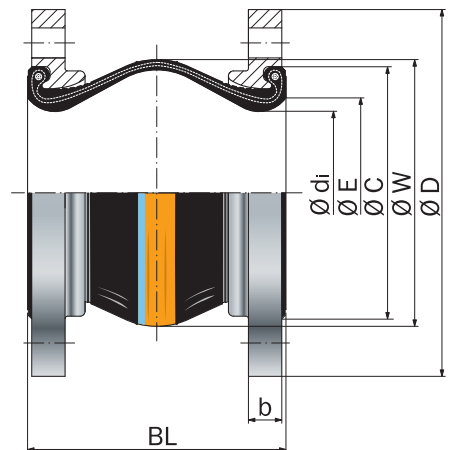

Type AS-1

Universal expansion joint without restraint

MOVEMENT COMPENSATION

DN	BL	Δ ax Axial movement		Δ lat Lateral movement	Δ ang* Angular movement	A** Effective bellows cross sectional area at 16 bar cm ²	Permissible vacuum w/o supporting ring at length BL bar absolute	Weight approx. kg
		Compression - mm	Elongation + mm					
25	125	30	10	15	25	0	0	2.2
32	125	30	10	15	25	0	0	3.3
32	150	35	15	20	25	-14	0.5	3.4
40	125	30	10	15	25	0	0	3.7
40	150	35	15	20	25	-25	0.7	3.8
50	125	30	10	15	25	0	0	4.4
50	150	35	15	20	25	-14	0.7	4.6
65	125	30	10	15	25	0	0	5.2
65	150	35	15	20	20	-25	0.7	5.4
80	150	40	10	15	20	12	0.2	7.2
100	150	40	10	15	15	9	0.4	8.0
125	150	40	10	15	15	18	0.65	10.7
150	150	40	10	15	12	52	0.65	13.0
175	150	40	10	15	10	54	0.7	15.9
200	150	20	20	10	8	285	0.8	18.8
200	175	45	15	15	8	56	0.7	19.1
250	175	45	15	15	7	191	0.7	24.8
250	200	35	15	15	6	54	0.5	25.1
300	200	45	15	15	6	255	0.75	30.9
350	200	45	15	15	5	563	0.5	42.0
400	200	45	15	15	5	875	0.3	51.0

* Larger Δ ang possible for compressed installation length.

**Effective bellows cross sectional area is a theoretical value.

Please inquire for simultaneous (different) movement.

RUBBER EXPANSION JOINT TYPE AS-1D

FLAME-PROOF

TWIN-CONVOLUTED UNIVERSAL EXPANSION JOINT DN 25 – DN 250

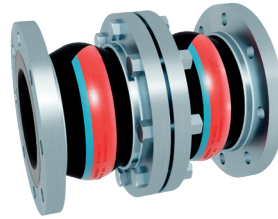

STRUCTURE TYPE AS-1D / RUBBER BELLOWS PN 16

- Universal expansion joint (double shafted), consisting of a rubber bellows and rotatable flanges
- Highly elastic molded bellows in various rubber grades
- Steel wire cord reinforcement
- Wire-reinforced self-sealing rubber rim
- Electrical impedance < 100 Ohm (DIN IEC 93, VDE 0303-30)

Rubber grade*	EPDM	NBR
Colour code	orange/blue	red/blue
Possible uses	Hot water, acids, lyes	hydrocarbon containing liquids

*Check or inquire about the resistance of the rubber grade to temperature and medium.

Technical design	
Max. perm. operating pressure	16 bar*
Max. perm. temperature	+130 °C
Bursting pressure	≥ 50 bar
Vacuum operation	DN 25 – 50 without vacuum supporting ring, DN 65 – 400 with vacuum supporting ring

Max. operating pressure to be set 30 % lower for shock loads.

*Please consider a decrease of pressure due to temperature (see technical annex).

FLANGES / VERSIONS

- Rotable flanges with stabilizing collar
- Flange drilling for through bolts, DN 25 with Drill holes
- Special machined groove for rubber rim

	Standard	Others
Dimensions	EN 1092	ANSI, BS etc. Connection dimensions see technical annex page 213 – 215
Materials	1.0038 (S235JR)	1.4541, 1.4571 etc.
Corrosion protection	electrogalvanized	hot-dip galvanized, special varnish, special coating, etc.

NOTE

Please comply with the general technical instructions regarding reaction force, moving force, fixed point load, installation instructions etc.

Subject to technical alterations and deviations resulting from the manufacturing process.

Chemicals used for water treatment (particularly in heating systems and coolant systems) can corrode the materials of the rubber expansion joint. According to VDI Directive 2035, DIN 4809 part 1 and VGB R 455P, the manufacturer of the chemicals must state that the materials used in the expansion joint, especially for the rubber bellows, will not be damaged by the chemicals.

APPLICATIONS

- for reducing thermal and mechanical tension in pipes and their system components, e.g.
 - pumps
 - compressors
 - engines
- for muffling vibration and noise
 - at appliances
 - in cooling water and lub oil pipes
- for compensating axial, lateral and angular movement
- to compensate for installation inaccuracies
- to meet fire protection regulations
- shipbuilding industry
- in heating plants

CERTIFICATES

- CE (PED 2014/68/EU)
- American Bureau of Shipping
- DNV GL® / DNV®
- Bureau Veritas
- Lloyd's Register of Shipping
- TÜV/DIN 4809 (DN 25 – 200)
- TÜV Süd (KTA)
- MED
- Others see technical annex

DIMENSIONS STANDARD PROGRAM

DN	BL*	Pressure rate	Ø dj Bellows inner Ø	Ø C Raised face outer Ø	Ø E Raised face inner Ø	Ø W*** Con- volution Ø	PN Flange connec- tion EN 1092	Ø D Flange outer Ø	b Flange thick- ness mm
	mm	bar	mm	mm	mm	mm		mm	mm
25	255	16	31±3	72	39	78	16**	115	16
32	255	16	31±3	72	39	78	16	140	16
32	305	16	31±3	72	39	88	16	140	16
40	255	16	39±3	81	45	86	16	150	16
40	305	16	39±3	81	45	96	16	150	16
50	255	16	49±3	95	56	97	16	165	16
50	305	16	49±3	95	56	107	16	165	16
65	255	16	65±3	115	72	113	16	185	18
65	305	16	65±3	115	72	123	16	185	18
80	305	16	77±3	127	84	135	16	200	20
100	305	16	100±3	151	109	160	16	220	20
125	305	16	127±3	178	133	184	16	250	22
150	305	16	153±3	206	161	212	16	285	22
175	305	16	176±3	230	185	236	16	315	22
200	305	10	202±3	260	209	265	10	340	25
200	355	10	202±3	260	209	265	10	340	25
250	355	10	252±3	313	262	318	10	395	25
250	405	10	252±3	313	262	318	10	395	25

* DN 25 up to DN 300 also available as type RS-1 in length 265.

** Flanges with drill holes M 12.

*** unpressurized

From DN 200 pressure rate 16 bar also available with flanges PN 16. Please contact us for further flange dimensions.

ACCESSORIES

- Vakuumstützring
- Leitrohr
- Schutzhaube
- Schutzrohr

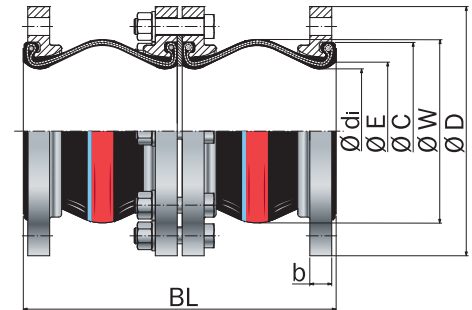

Type AS-1D

Universal expansion joint (double shafted) without restraint

MOVEMENT COMPENSATION

DN	BL	Δ ax Axial movement		Δ lat Lateral movement ± mm	Δ ang* Angular movement ± ∠ degrees	A** Effective bellows cross sectional area at 16 bar cm ²	Permissible vacuum w/o supporting ring at length BL bar absolute	Weight approx. kg
		Compression - mm	Elongation + mm					
25	255	60	20	55	50	0	0	4,9
32	255	60	20	55	50	0	0	7,4
32	305	70	30	65	50	-14	0,5	7,6
40	255	60	20	55	50	0	0	8,3
40	305	70	30	65	50	-25	0,7	8,5
50	255	60	20	55	50	0	0	9,7
50	305	70	30	65	50	-14	0,7	10,1
65	255	60	20	38	50	0	0	12,1
65	305	70	30	53	40	-25	0,7	12,5
80	305	80	20	38	40	12	0,2	16,2
100	305	80	20	30	30	9	0,4	17,9
125	305	80	20	25	30	18	0,65	23,5
150	305	80	20	20	24	52	0,65	29,3
175	305	80	20	17	20	54	0,7	35,2
200	305	40	40	21	16	285	0,8	42,6
200	355	90	30	25	16	56	0,7	43,2
250	355	90	30	21	14	191	0,7	57,6
250	405	70	30	21	12	54	0,5	58,2

* Larger Δ ang possible for compressed installation length.

**Effective bellows cross sectional area is a theoretical value.

Please inquire for simultaneous (different) movement.

RUBBER EXPANSION JOINT TYPE MS-1

FLAME-PROOF

TWIN-CONVOLUTED UNIVERSAL EXPANSION JOINT DN 65 – DN 250

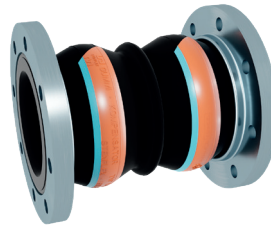

STRUCTURE TYPE MS-1 / RUBBER BELLOWS PN 16

- Universal expansion joint (double shafted), consisting of a rubber bellows and rotatable flanges
- Highly elastic molded bellows in various rubber grades
- Steel wire cord reinforcement
- Wire-reinforced self-sealing rubber rim

Rubber grade*	EPDM	NBR
Colour code	orange/blue	red/blue
Possible uses	Hot water, acids, lyes	hydrocarbon containing liquids

*Check or inquire about the resistance of the rubber grade to temperature and medium.

Technical design	
Max. perm. operating pressure	16 bar*
Max. perm. temperature	+130 °C
Bursting pressure	≥ 50 bar
Vacuum operation	with vacuum supporting ring (at permanent vacuum)

Max. operating pressure to be set 30 % lower for shock loads.

*Please consider a decrease of pressure due to temperature (see technical annex).

FLANGES / VERSIONS

- Rotatable flanges with stabilizing collar
- Flange drilling for through bolts
- Special machined groove for rubber rim annex

	Standard	Others
Dimensions	EN 1092	ANSI, BS etc. Connection dimensions see technical annex page 213 – 215
Materials	1.0038 (S235JR)	1.4541, 1.4571 etc.
Corrosion protection	electrogalvanized	hot-dip galvanized, special varnish, special coating, etc.

NOTE

Please comply with the general technical instructions regarding reaction force, moving force, fixed point load, installation instructions etc.

Subject to technical alterations and deviations resulting from the manufacturing process.

Chemicals used for water treatment (particularly in heating systems and coolant systems) can corrode the materials of the rubber expansion joint. According to VDI Directive 2035, DIN 4809 part 1 and VGB R 455P, the manufacturer of the chemicals must state that the materials used in the expansion joint, especially for the rubber bellows, will not be damaged by the chemicals.

APPLICATIONS

- for compensating large axial, lateral and angular movement
- for reducing thermal and mechanical tension in pipes and their system components, e.g.
 - pumps
 - compressors
 - engines
- for muffling vibration and noise
 - at appliances
 - in cooling water and lub oil
 - pipes
- to compensate for installation inaccuracies
- to meet fire protection regulations
- shipbuilding industry
- in heating plants

CERTIFICATES

- CE (DGR 2014/68/EU)
- American Bureau of Shipping
- DNV GL® / DNV®
- Bureau Veritas
- Lloyd's Register of Shipping
- RINA
- CCS
- MED

DIMENSIONS STANDARD PROGRAM

DN	BL	Pressure rate	Ø dj Bellows inner Ø mm	Ø C Raised face outer Ø mm	Ø E Raised face inner Ø mm	Ø W* Con- volution Ø mm	PN Flange con- nec- tion EN 1092	Ø D Flange outer Ø mm	b Flange thick- ness mm
65	220	16	63+5/63-1	115	72 ± 1	113	16	185	18
80	250	16	75+5/75-1	127	84 ± 1	135	16	200	20
100	275	16	98+5/98-1	151	109 ± 1	160	16	220	20
125	275	16	125+5/125-1	178	133 ± 1	184	16	250	22
150	275	16	151+5/151-1	206	161 ± 1	212	16	285	22
200	275	10	200+5/200-1	260	209 ± 1	265	10	340	25
250	275	10	250+5/250-1	313	262 ± 1	218	10	395	25

*unpressurized

Please contact us for further flange dimensions.

MOVEMENT COMPENSATION

DN	BL	Δ ax Axial movement		Δ lat Lateral move- ment ± mm	Δ ang* Angular move- ment ± \sphericalangle degrees	A** Effective bellows cross sectional area at 16 bar cm ²	Permissible vacuum w/o supporting ring at length BL bar absolute	Weight approx. kg
		Compression - mm	Elongation + mm					
65	220	70	30	38	30	14	0,0	6,05
80	250	90	30	40	30	12	0,0	7,90
100	275	90	30	40	30	16	0,4	9,17
125	275	80	25	30	30	15	1,0	11,80
150	275	80	25	30	24	29	0,4	14,40
200	275	90	35	30	16	152	0,7	20,40
250	275	90	35	15	10	328	1,0	28,00

* Larger Δ ang possible for compressed installation length.

**Effective bellows cross sectional area is a theoretical value.

Please inquire for simultaneous (different) movement.

ACCESSORIES

- Vacuum supporting ring
- Internal guide sleeve

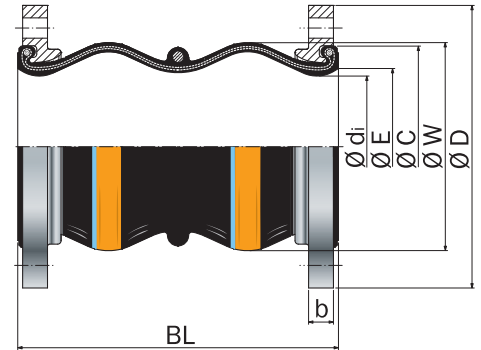

Type MS-1

Universal expansion joint without restraint

RUBBER EXPANSION JOINT TYPE AS-2, AS-4

FLAME-PROOF

LATERAL EXPANSION JOINT DN 25 – DN 400

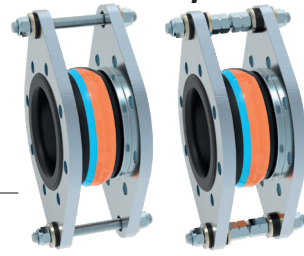

STRUCTURE TYPE AS-2, AS-4 / RUBBER BELLOWS PN 16

- **Type AS-2:** Lateral expansion joint consisting of a rubber bellows with rotatable flanges and tie rods (external restraints) to absorb reaction force from internal pressure
- **Type AS-4:** Lateral expansion joint consisting of a rubber bellows with rotatable flanges and tie rods (external and internal restraints) to absorb reaction force from internal pressure or vacuum
- Highly elastic molded bellows in various rubber grades
- Steel wire cord reinforcement
- Wire-reinforced self-sealing rubber rim
- Electrical impedance 10^3 to 10^6 Ohm (DIN IEC 93, VDE 0303-30)

Rubber grade*	EPDM	NBR
Colour code	orange/blue	red/blue
Possible uses	Hot water, acids, lyes	hydrocarbon containing liquids

*Check or inquire about the resistance of the rubber grade to temperature and medium

Technical design	
Max. perm. operating pressure	16 bar*
Max. perm. temperature	+130 °C
Bursting pressure	≥ 50 bar
Vacuum operation	DN 32 – 50 without vacuum supporting ring, DN 65 – 400 with vacuum supporting ring

Max. operating pressure to be set 30 % lower for shock loads.

*Please consider a decrease of pressure due to temperature (see technical annex).

FLANGES / VERSIONS

- Flanges with stabilizing collar and ears to carry the tie rods
- Flange drilling for through bolts, DN 25 with Drill holes
- Special machined groove for rubber rim

	Standard	Others
Dimensions	EN 1092	ANSI, BS etc. Connection dimensions see technical annex page 213 – 215
Materials	1.0038 (S235JR)	1.4541, 1.4571 etc.
Corrosion protection	electrogalvanized	hot-dip galvanized, special varnish, special coating, etc.

NOTE

Subject to technical alterations and deviations resulting from the manufacturing process.

Chemicals used for water treatment (particularly in heating systems and coolant systems) can corrode the materials of the rubber expansion joint. According to VDI Directive 2035, DIN 4809 part 1 and VGB R 455P, the manufacturer of the chemicals must state that the materials used in the expansion joint, especially for the rubber bellows, will not be damaged by the chemicals.

APPLICATIONS

- for reducing thermal and mechanical tension in pipes and their system components, e.g
 - pumps
 - compressors
 - engines
- for muffling vibration and noise
 - at appliances
 - in cooling water and lub oil pipes
- for compensating lateral movement
- to compensate for installation inaccuracies
- to meet fire protection regulations
- shipbuilding industry
- in heating plants

TIE ROD RESTRAINTS

- DN 25 – DN 150 Tie rods carried on silencing rubber sockets
- DN 175 – DN 400 Tie rods carried on spherical washers and conical seats

Materials

Standard: tie rods 8.8

Others: stainless steel

Corrosion protection

Standard: electrogalvanized

Others: hot-dip galvanized

DIMENSIONS STANDARD PROGRAM

DN	BL	Pressure rate	Ø dj Bellows inner Ø	Ø C Raised face outer Ø	Ø E Raised face inner Ø	Ø W* Con-volution Ø	PN Flange connection EN 1092	Ø D Flange outer Ø	b Flange thickness	H Flange height
	mm	bar	mm	mm	mm	mm		mm	mm	mm
25	125	16	31 ± 3	72	39	78	16	115	16	220
32	125	16	31 ± 3	72	39	78	16	140	16	220
32	150	16	31 ± 3	72	39	88	16	140	16	220
40	125	16	39 ± 3	81	45	86	16	150	16	230
40	150	16	39 ± 3	81	45	96	16	150	16	230
50	125	16	49 ± 3	95	56	97	16	165	16	240
50	150	16	49 ± 3	95	56	107	16	165	16	240
65	125	16	65 ± 3	115	72	113	16	185	18	260
65	150	16	65 ± 3	115	72	123	16	185	18	260
80	150	16	77 ± 3	127	84	135	16	200	20	300
100	150	16	100 ± 3	151	109	160	16	220	20	350
125	150	16	127 ± 3	178	133	184	16	250	22	385
150	150	16	153 ± 3	206	161	212	16	285	22	420
175	150	16	176 ± 3	230	185	236	16	315	22	440
200	150	10	202 ± 3	260	209	265	10	340	25	465
200	175	10	202 ± 3	260	209	265	10	340	25	465
250	175	10	252 ± 3	313	262	318	10	395	25	520
250	200	10	252 ± 3	313	262	318	10	395	25	520
300	200	10	303 ± 3	363	312	373	10	445	25	570
350	200	10	344 ± 3	423	360	420	10	505	30	630
400	200	10	396 ± 3	474	410	460	10	565	30	690

*unpressurized. From DN 200 higher pressure rate available on request. Please contact us for further flange dimensions.

MOVEMENT COMPENSATION / FLANGE VERSIONS

DN	BL	Δ lat Lateral movement ± mm	Permissible vacuum w/o supporting ring at length BL bar absolute	Weight type AS-2 approx. kg
	mm			
25	125	15	0	4.2
32	125	15	0	5.1
32	150	20	0.5	5.2
40	125	15	0	5.6
40	150	20	0.7	5.7
50	125	15	0	6.2
50	150	20	0.7	6.4
65	125	15	0	7.9
65	150	20	0.7	8.1
80	150	15	0.2	10.7
100	150	15	0.4	12.6
125	150	15	0.65	16.8
150	150	15	0.65	19.6
175	150	15	0.7	20.3
200	150	15	0.8	22.9
200	175	15	0.7	23.2
250	175	15	0.7	28.1
250	200	15	0.5	28.4
300	200	15	0.75	32.2
350	200	15	0.5	44.7
400	200	15	0.3	58.6

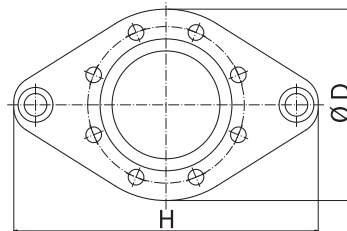

DN 25 - DN 150

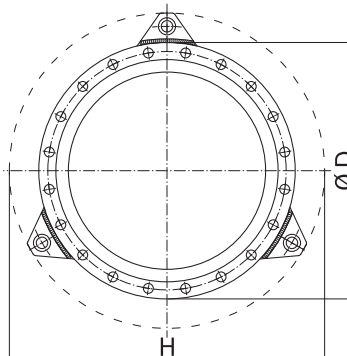

DN 175 - DN 400

Number of tie rods depending on pressure

CERTIFICATES

- CE (PED 2014/68/EU)
- American Bureau of Shipping
- Bureau Veritas
- MED
- DNV GL® / DNV®
- Lloyd's Register of Shipping
- TÜV/DIN 4809
- TÜV Süd (KTA)
- Others see technical annex

ACCESSORIES

- Vacuum supporting ring
- Internal guide sleeve
- Protective hood
- Protective tube

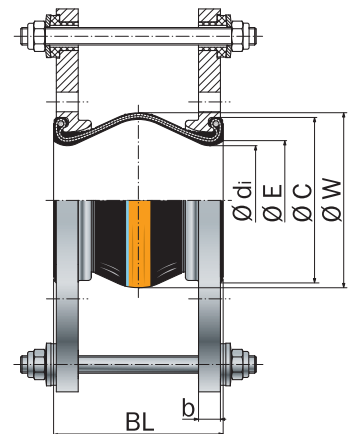

Type AS-2

Tie rods, external restraints, carried on silencing rubber sockets

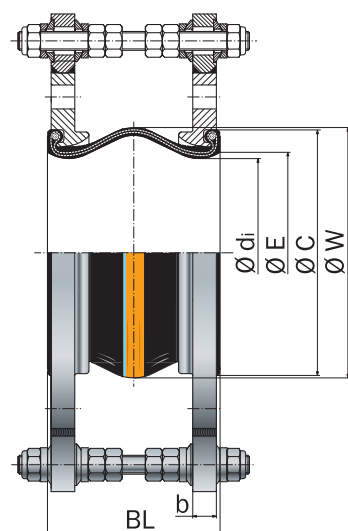

Type AS-4

Design as type AS-2, additional internal restraints, carried on spherical washers and conical seats

RUBBER EXPANSION JOINT TYPE AS-3

FLAME-PROOF

ANGULAR EXPANSION JOINT

DN 32 – DN 400

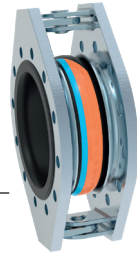

STRUCTURE TYPE AS-3 / RUBBER BELLOWS PN 16

- Angular expansion joint consisting of a rubber bellows and flanges
- Welded hinge restraints to absorb reaction force from internal pressure or vacuum
- Highly elastic molded bellows in various rubber grades
- Steel wire cord reinforcement
- Wire-reinforced self-sealing rubber rim
- Electrical impedance < 100 Ohm (DIN IEC 93, VDE 0303-30)

Rubber grade*	EPDM	NBR
Colour code	orange/blue	red/blue
Possible uses	Hot water, acids, lyes	hydrocarbon containing liquids

*Check or inquire about the resistance of the rubber grade to temperature and medium.

Technical design	
Max. perm. operating pressure	16 bar*
Max. perm. temperature	+130 °C
Bursting pressure	≥ 50 bar
Vacuum operation	DN 32 – 50 without vacuum supporting ring, DN 65 – 400 with vacuum supporting ring

Max. operating pressure to be set 30 % lower for shock loads.

*Please consider a decrease of pressure due to temperature (see technical annex).

FLANGES / VERSIONS

- Oval flanges with stabilizing collar and hinge restraints
- Flange drilling for through bolts
- Special machined groove for rubber rim

	Standard	Others
Dimensions	EN 1092	ANSI, BS etc. Connection dimensions see technical annex page 213 – 215
Materials	1.0038 (S235JR)	stainless steel etc.
Corrosion protection	electrogalvanized	anti-corrosion primed, hot-dip galvanized, special varnish and coating, etc.

NOTE

Please comply with the general technical instructions regarding reaction force, moving force, fixed point load, installation instructions etc.

Subject to technical alterations and deviations resulting from the manufacturing process.

Chemicals used for water treatment (particularly in heating systems and coolant systems) can corrode the materials of the rubber expansion joint. According to VDI Directive 2035, DIN 4809 part 1 and VGB R 455P, the manufacturer of the chemicals must state that the materials used in the expansion joint, especially for the rubber bellows, will not be damaged by the chemicals.

APPLICATIONS

- for compensating angular movement
- as double or triple joint compensation system for large movements
 - for tank settlement during filling
 - in plastic pipe systems
- to meet fire protection regulations
 - in shipbuilding industry
 - in chemical industry

HINGE RESTRAINTS

- Pivot of joint bars at center of bellows
- Hinge restraints control bellows movement

Materials

Standard: 1.0038 (S235JR),
1.0577 (S355J2)

Others: stainless steel, etc.

Corrosion protection

Standard: DN 32 - DN 175
electrogalvanized
DN 200 - DN 400
anti-corrosion primed

Others: hot-dip galvanized, special varnish and coating, etc

DIMENSIONS STANDARD PROGRAM

DN	BL*	Pressure rate	Ø dj Bellows inner Ø	Ø C Raised face outer Ø	Ø E Raised face inner Ø	Ø W** Con- volution Ø	PN Flange connec- tion EN 1092	Ø D Flange outer Ø	b Flange thick- ness mm	H Flange height mm
	mm	bar	mm	mm	mm	mm		mm	mm	mm
32	125	16	31 ± 3	72	39	78	16	140	16	220
40	125	16	39 ± 3	81	45	86	16	150	16	230
50	125	16	49 ± 3	95	56	97	16	165	16	240
65	125	16	65 ± 3	115	72	113	16	185	18	260
80	150	16	77 ± 3	127	84	135	16	200	20	300
100	150	16	100 ± 3	151	109	160	16	220	20	350
125	150	16	127 ± 3	178	133	184	16	250	22	385
150	150	16	153 ± 3	206	161	212	16	285	22	420
175	150	16	176 ± 3	230	185	236	16	315	22	450
200	175	10	202 ± 3	260	209	265	10	340	25	440
250	175	10	252 ± 3	313	262	318	10	385	25	505
300	200	10	303 ± 3	363	312	373	10	445	25	560
350	200	10	344 ± 3	423	360	425	10	505	34	620
400	200	10	396 ± 3	474	410	470	10	565	38	680

From DN 200 higher pressure rate available on request. Please contact us for further flange dimensions. *The measure BL (length) for DN 400 is approx. 6 mm shorter when fitted. **unpressurized

MOVEMENT COMPENSATION / FLANGE VERSIONS

DN	Δ ang Angular movement ± ∠ degrees	Weight approx. kg
32	25	6.0
40	25	6.5
50	25	7.2
65	25	8.6
80	20	12.1
100	15	14.0
125	15	17.6
150	12	20.4
175	10	23.1
200	8	34.5
250	7	39.6
300	6	45.2
350	5	67.0
400	5	93.0

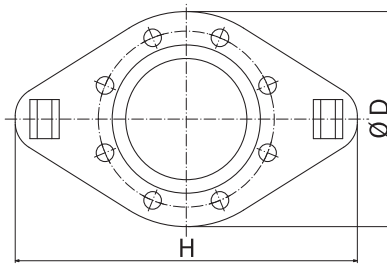

DN 32 - DN 150

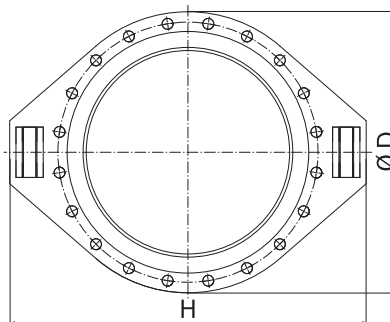

DN 175 - DN 400

CERTIFICATES

- CE (PED 2014/68/EU)
- RINA
- MED
- DNV GL® / DNV®
- Lloyd's Register of Shipping
- TÜV/DIN 4809
- Others see technical annex

ACCESSORIES

- Vacuum supporting ring
- Internal guide sleeve
- Protective hood

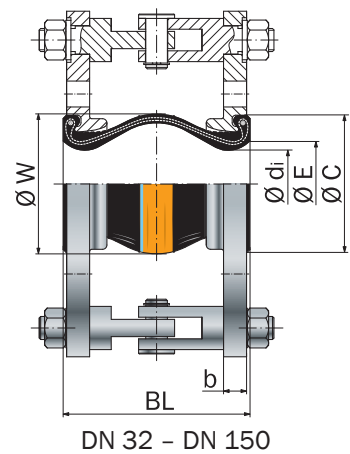

DN 32 - DN 150

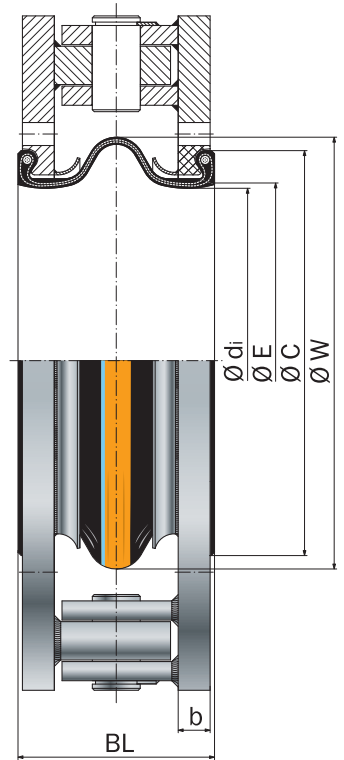

DN 175 - DN 400

Type AS-3

Angular expansion joint with hinge restraints

RUBBER EXPANSION JOINT TYPE VS-1

FLAME-PROOF

UNIVERSAL EXPANSION JOINT DN 40 – DN 150

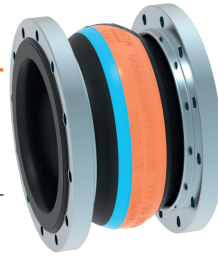

STRUCTURE TYPE VS-1 / RUBBER BELLOWS PN 16

- Universal expansion joint, consisting of a rubber bellows and rotating flanges
- Highly elastic molded bellows in various rubber grades
- Steel wire cord reinforcement
- Wire-reinforced self-sealing rubber rim
- Electrical impedance < 100 Ohm (DIN IEC 93, VDE 0303-30)

Rubber grade*	EPDM	NBR
Colour code	orange/blue	red/blue
Possible uses	Hot water, acids, lyes	hydrocarbon containing liquids

*Check or inquire about the resistance of the rubber grade to temperature and medium.

Technical design			
Max. perm. operating pressure	16 bar	10 bar	6 bar
Max. perm. temperature	up to +60 °C	up to +100 °C	up to +110 °C
	up to +130 °C for brief periods*		
Bursting pressure	≥ 50 bar		
Vacuum operation	≥ 0,05 bar abs. with vacuum supporting ring (from DN 65)		

Max. operating pressure to be set 30 % lower for shock loads.

*> +110 °C the manufacturer's approval must be obtained for the corresponding operating conditions.

FLANGES / VERSIONS

- Rotating flanges with stabilizing collar
- Flange drilling for through bolts
- Special turned groove for rubber rim

	Standard	Others
Dimensions	VG 85356	
Materials	1.0038 (RSt 37-2)	1.4541, 1.4571 etc.
Corrosion protection	electrogalvanized	hot-dip galvanized, special varnish and coating, etc.

NOTE

Please comply with the general technical instructions regarding reaction force, moving force, fixed point load, installation instructions etc.

Subject to technical alterations and deviations resulting from the manufacturing process.

Chemicals used for water treatment (particularly in heating systems and coolant systems) can corrode the materials of the rubber compensator. According to VDI Directive 2035, DIN 4809 part 1 and VGB R 455P, the manufacturer of the chemicals must state that the materials used in the compensator, especially for the rubber bellows, will not be damaged by the chemicals.

APPLICATIONS

- for reducing thermal and mechanical tension in pipes and their system components, e.g.
 - pumps
 - compressors
 - engines
- for muffling vibration and noise
 - at appliances
 - in cooling water and lub oil pipes
- for compensating axial, lateral and angular movement
- to compensate for installation inaccuracies
- to meet fire protection regulations
- shipbuilding industry
- in heating plants

CERTIFICATES

- CE (DGR 97/23/EG)

ACCESSORIES

- Vacuum supporting ring
- Internal guide sleeve

DIMENSIONS STANDARD PROGRAM

DN	BL	Pressure rate	Ø di Bellows inner Ø	Ø C Raised face Ø	Ø E Raised face inner Ø	Ø W* Con- volution Ø	Ø K pitch circle diam. Ø	n x Ø d number x bore diam. Ø	Ø D Flange outer Ø	b Flange thick- ness mm
	mm	bar	mm	mm	mm	mm	mm	mm	mm	mm
40	125	16	32 ± 3	71	42	74	84	6 x 11	108	16
50	125	16	40 ± 3	83	50	88	96	6 x 11	120	16
65	125	16	61 ± 3	103	68	113	116	8 x 11	140	18
80	150	16	72 ± 3	113	81	137	126	8 x 11	150	18
100	150	16	93 ± 3	135	101	145	148	10 x 11	172	18
125	150	16	117 ± 4	163	127	178	176	10 x 11	200	20
150	150	16	143 ± 5	189	151	201	202	12 x 11	226	20

*unpressurized

MOVEMENT COMPENSATION

DN	Δ ax Axial movement		Δ lat Lateral movement ± mm	Δ ang* Angular movement ± ∠ degrees	A** Effective bellows cross sectional area at 16 bar cm ²	Weight approx. kg
	Compression - mm	Elongation + mm				
40	30	10	15	25	0	1.9
50	30	10	15	21	0	2.3
65	30	10	15	17	19	3.0
80	40	10	15	14	23	3.4
100	40	10	15	11	28	4.2
125	40	10	15	9	49	5.7
150	40	10	15	7	81	6.6

* Larger Δ ang possible for compressed installation length.
 **Effective bellows cross sectional area is a theoretical value.
 Please inquire for simultaneous (different) movement.

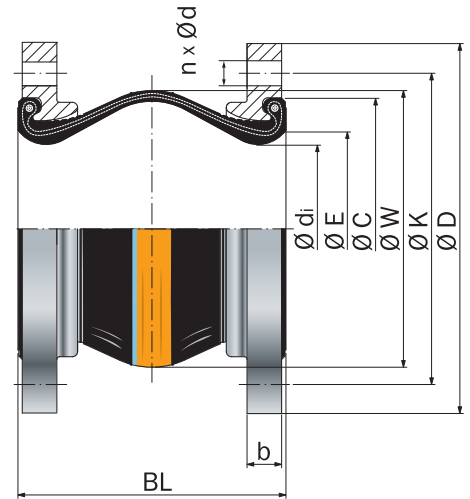

DN 40 - DN 150

Type VS-1

Universal compensator without restraint

RUBBER EXPANSION JOINT TYPE AR-1

UNIVERSAL EXPANSION JOINT DN 20 – DN 600

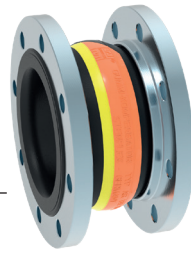

STRUCTURE TYPE AR-1 / RUBBER BELLOWS PN 25

- Universal expansion joint, consisting of a rubber bellows and rotatable flanges
- Highly elastic molded bellows in various rubber grades
- High-tensile synthetic fibre reinforcement
- Wire-reinforced self-sealing rubber rim
- Electrical impedance 10^3 to 10^6 Ohm (DIN IEC 93, VDE 0303-30)

Rubber grade*	EPDM	NBR
Colour code	orange/yellow	red/yellow
Possible uses	Hot water, acids, lyes	hydrocarbon containing liquids

*Check or inquire about the resistance of the rubber grade to temperature and medium.

Technical design	
Max. perm. operating pressure	25 bar*
Max. perm. temperature	+130 °C
Bursting pressure	≥ 75 bar
Vacuum operation	DN 20 – 50 without vacuum supporting ring, DN 65 – 600 with vacuum supporting ring

Max. operating pressure to be set 30 % lower for shock loads.

*Please consider a decrease of pressure due to temperature (see technical annex).

FLANGES / VERSIONS

- Rotatable flanges with stabilizing collar
- Flange drilling for through bolts
- Special machined groove for rubber rim

	Standard	Others
Dimensions	EN 1092	ANSI, BS etc. Connection dimensions see technical annex page 213 – 215
Materials	1.0038 (S235JR)	1.4541, 1.4571 etc.
Corrosion protection	electrogalvanized	hot-dip galvanized, special varnish and coating, etc.

NOTE

Please comply with the general technical instructions regarding reaction force, moving force, fixed point load, installation instructions etc.

Subject to technical alterations and deviations resulting from the manufacturing process.

APPLICATIONS

- for reducing thermal and mechanical tension in pipes and their system components, e.g.
 - pumps
 - compressors
- for muffling vibration and noise
 - at appliances
 - in cooling water and lube oil pipes
- for compensating axial, lateral and angular movement
- for compensating simultaneous movement in cooling water pipes
- to compensate for installation inaccuracies
- in sprinkler systems

CERTIFICATES

- CE (PED 2014/68/EU)

ACCESSORIES

- Vacuum supporting ring
- Internal guide sleeve
- Flame-proof protective cover
- Protective hood
- Protective tube

DIMENSIONS STANDARD PROGRAM

DN	BL	Pressure rate	Ø dj Bellows inner Ø	Ø C Raised face outer Ø	Ø E Raised face inner Ø	Ø W** Con- volution Ø	PN* Flange connec- tion EN 1092	Ø D Flange outer Ø	b Flange thick- ness
	mm	bar	mm	mm	mm	mm		mm	mm
20	100	25	22 ± 3	51	30	55	25	115	16
25	100	25	22 ± 3	51	30	55	25	115	16
32	125	25	31 ± 3	72	39	78	25	140	16
40	125	25	39 ± 3	81	45	86	25	150	16
50	125	25	49 ± 3	95	56	97	25	165	16
65	125	25	65 ± 3	115	72	113	25	185	18
80	150	25	77 ± 3	127	84	135	25	200	20
100	150	25	100 ± 3	151	109	160	25	235	20
125	150	25	127 ± 3	178	133	184	25	270	22
150	150	25	153 ± 3	206	161	212	25	300	22
200	175	25	202 ± 3	260	209	265	25	360	25
250	175	25	252 ± 3	313	262	318	25	425	25
300	200	25	303 ± 3	363	312	373	25	485	25
350	200	25	344 ± 3	423	360	420	25	555	30
400	200	25	396 ± 3	474	410	460	25	620	30
500	250	25	485 ± 8	584	500	625	25	730	35
600	250	25	585 ± 8	684	600	725	25	845	40

*also available with flanges PN 16 and PN 10.

**unpressurized

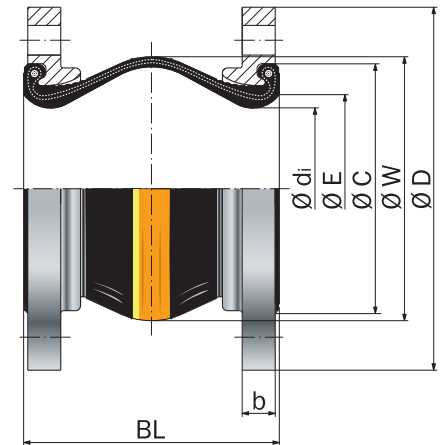

Type AR-1

Universal expansion joint, without restraint

MOVEMENT COMPENSATION

DN	Δ ax Axial movement		Δ lat Lateral movement	Δ ang* Angular movement	A** Effective bellows cross sectional area at 25 bar	Permissible vacuum w/o supporting ring at length BL bar absolute	Weight approx. kg
	Compression - mm	Elongation + mm					
20	20	10	10	± 25	0	-	2.3
25	20	10	10	± 25	0	-	2.3
32	35	10	15	± 25	0	0	3.3
40	35	10	15	± 25	1	0.5	3.7
50	35	10	15	± 25	1	0.4	4.4
65	35	10	15	± 25	1	0.5	4.9
80	40	10	15	± 20	2	0.6	6.5
100	40	10	15	± 15	5	0.6	9.5
125	40	10	15	± 15	8	0.5	13.0
150	40	10	15	± 12	41	0.4	15.3
200	45	15	15	± 8	54	0.6	21.8
250	45	15	15	± 7	72	0.6	31.6
300	45	15	15	± 6	226	0.6	41.6
350	45	15	15	± 5	460	0.65	56.7
400	45	15	15	± 5	880	0.8	69.0
500	50	30	15	± 7	2164	0.6	99.0
600	50	30	20	± 6	3201	0.5	141.0

* Larger Δ ang possible for compressed installation length.

**Effective bellows cross sectional area is a theoretical value.

Please inquire for simultaneous (different) movement.

RUBBER EXPANSION JOINT TYPE AR-2, AR-4

LATERAL EXPANSION JOINT DN 20 – DN 600

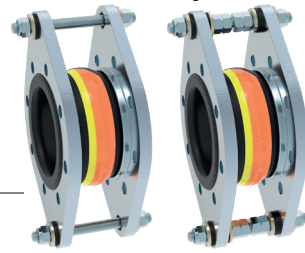

STRUCTURE TYPE AR-2, AR-4 / RUBBER BELLOWS PN 25

- **Type AR-2:** Lateral expansion joint consisting of a rubber bellows with rotatable flanges and tie rods (external restraints) to absorb reaction force from internal pressure
- **Type AR-4:** Lateral expansion joint consisting of a rubber bellows with rotatable flanges and tie rods (external and internal restraints) to absorb reaction force from internal pressure or vacuum
- Highly elastic molded bellows in various rubber grades
- High-tensile synthetic fibre reinforcement
- Wire-reinforced self-sealing rubber rim
- Electrical impedance 10^3 to 10^6 Ohm (DIN IEC 93, VDE 0303-30)

Rubber grade*	EPDM	NBR
Colour code	orange/yellow	red/yellow
Possible uses	Hot water, acids, lyes	hydrocarbon containing liquids

*Check or inquire about the resistance of the rubber grade to temperature and medium.

Technical design	
Max. perm. operating pressure	25 bar*
Max. perm. temperature	+130 °C
Bursting pressure	≥ 75 bar
Vacuum operation	DN 20 – 50 without vacuum supporting ring, DN 65 – 600 with vacuum supporting ring

Max. operating pressure to be set 30 % lower for shock loads.

*Please consider a decrease of pressure due to temperature (see technical annex).

FLANGES / VERSIONS

- Flanges with stabilizing collar and ears to carry the tie rods
- Flange drilling for through bolts
- Special machined groove for rubber rim

	Standard	Others
Dimensions	EN 1092	ANSI, BS etc. Connection dimensions see technical annex page 213 – 215
Materials	1.0038 (S235JR)	1.4541, 1.4571 etc.
Corrosion protection	electrogalvanized	hot-dip galvanized, special varnish and coating, etc.

NOTE

Please comply with the general technical instructions regarding reaction force, moving force, fixed point load, installation instructions etc.

Subject to technical alterations and deviations resulting from the manufacturing process.

APPLICATIONS

- for reducing thermal and mechanical tension in pipes and their system components, e.g.
 - pumps
 - compressors
- for muffling vibration and noise
 - at appliances
 - in cooling water and lube oil pipes
- for compensating lateral movement
- to compensate for installation inaccuracies
- in sprinkler systems

TIE ROD RESTRAINTS

- DN 20 – DN 150 Tie rods carried on silencing rubber sockets
- DN 200 – DN 600 Tie rods carried on spherical washers and conical seats

Materials

Standard: tie rods 8.8

Others: stainless steel

Corrosion protection

Standard: electrogalvanized

Others: hot-dip galvanized

CERTIFICATES

- CE (PED 2014/68/EU)

ACCESSORIES

- Vacuum supporting ring
- Internal guide sleeve
- Flame-proof protective cover
- Protective hood
- Protective tube

DIMENSIONS STANDARD PROGRAM

DN	BL	Pressure rate	Ø dj Bellows inner Ø	Ø C Raised face outer Ø	Ø E Raised face inner Ø	Ø W** Con-volution Ø	PN* Flange connection EN 1092	Ø D Flange outer Ø	b Flange thickness	H Flange height
	mm	bar	mm	mm	mm	mm		mm	mm	mm
20	100	25	22 ± 3	51	30	55	25	115	16	195
25	100	25	22 ± 3	51	30	55	25	115	16	195
32	125	25	31 ± 3	72	39	78	25	140	16	220
40	125	25	39 ± 3	81	45	86	25	150	16	230
50	125	25	49 ± 3	95	56	97	25	165	16	240
65	125	25	65 ± 3	115	72	113	25	185	18	260
80	150	25	77 ± 3	127	84	135	25	200	20	300
100	150	25	100 ± 3	151	109	160	25	235	20	350
125	150	25	127 ± 3	178	133	184	25	270	22	385
150	150	25	153 ± 3	206	161	212	25	300	22	420
200	175	25	202 ± 3	260	209	265	25	360	25	485
250	175	25	252 ± 3	313	262	318	25	425	25	550
300	200	25	303 ± 3	363	312	373	25	485	25	610
350	200	25	344 ± 3	423	360	420	25	555	30	680
400	200	25	396 ± 3	474	410	460	25	620	30	745
500	250	35	485 ± 8	584	500	625	25	730	35	910
600	250	25	585 ± 8	684	600	725	25	845	40	1025

* also available with flanges PN 16 and PN 10.

**unpressurized

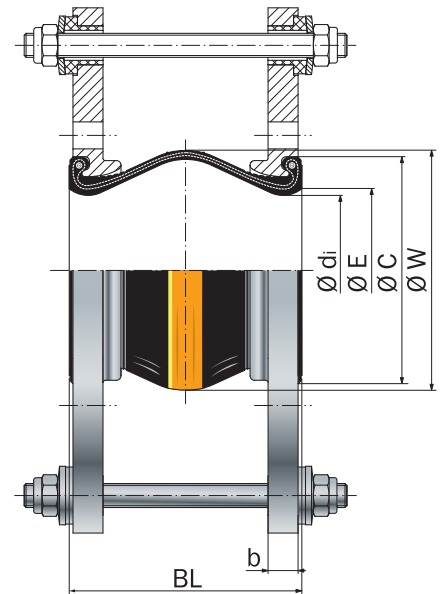

Type AR-2

Tie rods, external restraints, carried on silencing rubber sockets

MOVEMENT COMPENSATION / FLANGE VERSIONS

DN	Δ lat Lateral movement ± mm	Permissible vacuum w/o supporting ring at length BL bar absolute	Weight type AR-2 approx. kg
20	10	-	3.9
25	10	-	3.9
32	15	0	5.1
40	15	0.5	5.6
50	15	0.4	6.2
65	15	0.5	7.6
80	15	0.6	10.7
100	15	0.6	13.8
125	15	0.5	18.6
150	15	0.4	21.2
200	15	0.6	27.3
250	15	0.6	35.4
300	15	0.6	42.5
350	15	0.65	74.0
400	15	0.8	85.7
500	15	0.6	168.6
600	20	0.5	220.6

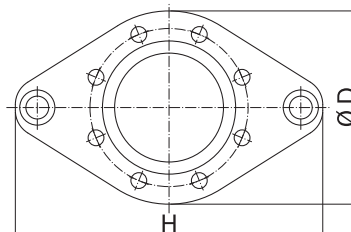

DN 20 - DN 150

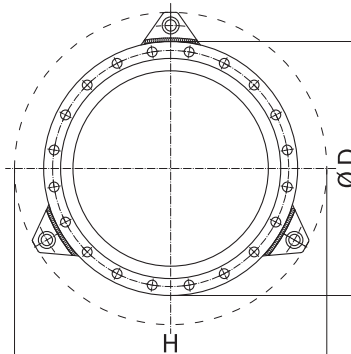

DN 200 - DN 600

Number of tie rods depending on pressure

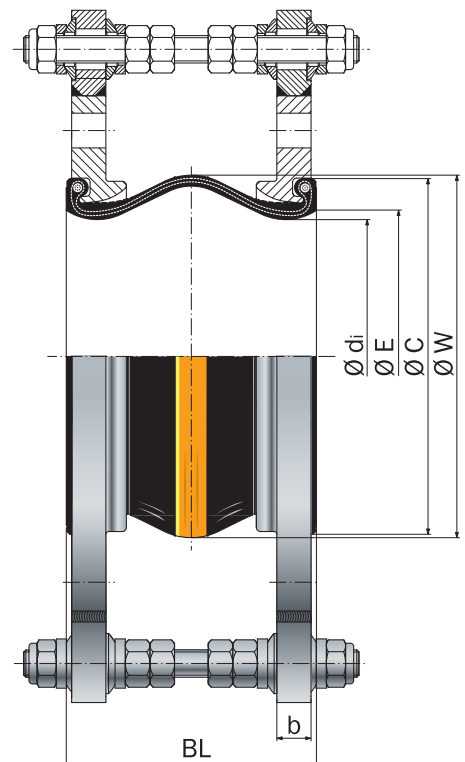

Type AR-4

Design as type AR-2, additional internal restraints, carried on spherical washers and conical seats

RUBBER EXPANSION JOINT TYPE R-1

LENGTH 130 MM

UNIVERSAL EXPANSION JOINT DN 25 – DN 300

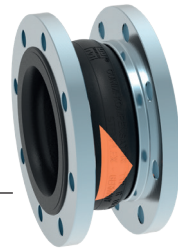

STRUCTURE TYPE R-1 / RUBBER BELLOWS PN 16

- Universal expansion joint consisting of a rubber bellows and rotatable flanges
- Flat-convoluted molded bellows in various rubber grades
- Synthetic fibre reinforcement
- Wire-reinforced self-sealing rubber rim
- Electrical impedance 10^3 to 10^6 Ohm (DIN IEC 93, VDE 0303-30)

Rubber grade*	EPDM	NBR	CIIR
Colour code	orange	red	white
Possible uses	Hot water, acids, lyes	hydrocarbon containing liquids	Drinking water

*Check or inquire about the resistance of the rubber grade to temperature and medium.

Technical design	
Max. perm. operating pressure	16 bar*
Max. perm. temperature	+100 °C
Bursting pressure	≥ 48 bar
Vacuum operation	DN 25 – 50 without vacuum supporting ring, DN 65 – 300 with vacuum supporting ring

Max. operating pressure to be set 30 % lower for shock loads.

*Please consider a decrease of pressure due to temperature (see technical annex).

FLANGES / VERSIONS

- Rotatable flanges with stabilizing collar
- Flange drilling for through bolts, DN 25 with Drill holes
- Special machined groove for rubber rim

	Standard	Others
Dimensions	EN 1092	ANSI, BS etc. Connection dimensions see technical annex page 213 – 215
Materials	1.0038 (S235JR)	1.4541, 1.4571
Corrosion protection	electrogalvanized	hot-dip galvanized, special varnish, special coating, etc.

NOTE

Please comply with the general technical instructions regarding reaction force, moving force, fixed point load, installation instructions etc.

Subject to technical alterations and deviations resulting from the manufacturing process.

APPLICATIONS

- for reducing thermal and mechanical tension in pipes and their system components, e.g.
 - pumps
 - compressors
 - engines
- for muffling vibration and noise
- for compensating axial, lateral and angular movement
- to compensate for installation inaccuracies
- as installation and dismantling aid

CERTIFICATES

- CE (PED 2014/68/EU)
- Bureau Veritas
- DNV GL® / DNV®
- Lloyd's Register of Shipping
- TÜV Süd (KTA)
- Drinking water

ACCESSORIES

- Vacuum supporting ring
- Internal guide sleeve
- Flame-proof protective cover
- Protective hood
- Protective tube

DIMENSIONS STANDARD PROGRAM

DN	BL	Pressure rate	Ø dj Bellows inner Ø	Ø C Raised face outer Ø	Ø E Raised face inner Ø	Ø W* Con- volution Ø	PN Flange connec- tion EN 1092	Ø D Flange outer Ø	b Flange thick- ness
	mm	bar	mm	mm	mm	mm		mm	mm
25	130	16	31 ± 3	72	39	88	16	115	16
32	130	16	31 ± 3	72	39	88	16	140	16
40	130	16	39 ± 3	81	45	96	16	150	16
50	130	16	49 ± 3	95	56	107	16	165	16
65	130	16	65 ± 3	115	72	123	16	185	18
80	130	16	77 ± 3	127	84	135	16	200	20
100	130	16	100 ± 3	151	109	160	16	220	20
125	130	16	127 ± 3	178	133	184	16	250	22
150	130	16	153 ± 3	206	161	212	16	285	22
200	130	10	202 ± 3	260	209	260	10	340	25
250	130	10	252 ± 3	313	262	313	10	395	25
300	130	10	303 ± 3	363	312	363	10	445	25

*unpressurized

From DN 200 pressure rate 16 bar also available with flanges PN 16.
Please contact us for further flange dimensions.

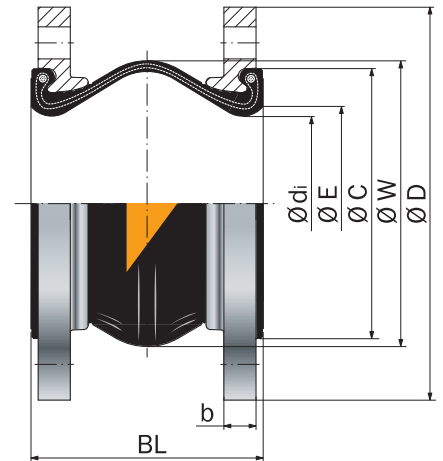

Type R-1

Universal expansion joint without restraint

MOVEMENT COMPENSATION

DN	Δ ax Axial movement		Δ lat Lateral move- ment ± mm	Δ ang* Angular move- ment ± < degrees	A** Effective bellows cross sectional area at 16 bar cm ²	Permissible vacuum w/o supporting ring at length BL bar absolute	Weight approx. kg
	Compression - mm	Elongation + mm					
25	35	10	15	25	8	-	2.2
32	35	10	15	25	8	0.6	3.3
40	35	10	15	25	9	0.6	3.8
50	35	10	15	25	19	0.6	4.5
65	35	10	15	25	33	0.7	5.2
80	30	10	15	20	53	0.65	7.1
100	30	10	15	15	98	0.6	8.0
125	30	10	15	15	103	0.75	10.5
150	30	10	15	10	203	0.65	12.8
200	25	10	15	7	379	0.7	18.2
250	25	10	15	6	525	0.7	23.7
300	20	10	15	5	769	0.8	30.4

* Larger Δ ang possible for compressed installation length.

**Effective bellows cross sectional area is a theoretical value.

Please inquire for simultaneous (different) movement.

RUBBER EXPANSION JOINT TYPE R-2

LENGTH 130 MM

LATERAL EXPANSION JOINT DN 25 – DN 300

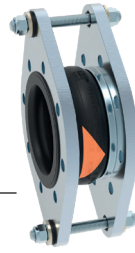

STRUCTURE TYPE R-2 / RUBBER BELLOWS PN 16

- Lateral expansion joint consisting of a rubber bellows with rotatable flanges and tie rods (external restraints) to absorb reaction force from internal pressure.
- Flat-convoluted molded bellows in various rubber grades
- Synthetic fibre reinforcement
- Wire-reinforced self-sealing rubber rim
- Electrical impedance 10^3 to 10^6 Ohm (DIN IEC 93, VDE 0303-30)

Rubber grade*	EPDM	NBR	CIIR
Colour code	orange	red	white
Possible uses	Hot water, acids, lyes	hydrocarbon containing liquids	Drinking water

*Check or inquire about the resistance of the rubber grade to temperature and medium

Technical design	
Max. perm. operating pressure	16 bar*
Max. perm. temperature	+100 °C
Bursting pressure	≥ 48 bar
Vacuum operation	DN 25 – 50 without vacuum supporting ring, DN 65 – 300 with vacuum supporting ring

Max. operating pressure to be set 30 % lower for shock loads.

*Please consider a decrease of pressure due to temperature (see technical annex).

FLANGES / VERSIONS

- Flanges with stabilizing collar and ears to carry the tie rods
- Flange drilling for through bolts, DN 25 with Drill holes
- Special machined groove for rubber rim

	Standard	Others
Dimensions	EN 1092	ANSI, BS etc. Connection dimensions see technical annex page 213 – 215
Materials	1.0038 (S235JR)	1.4541, 1.4571
Corrosion protection	electrogalvanized	hot-dip galvanized, special varnish, special coating, etc.

NOTE

Please comply with the general technical instructions regarding reaction force, moving force, fixed point load, installation instructions etc.

Subject to technical alterations and deviations resulting from the manufacturing process.

APPLICATIONS

- for reducing thermal and mechanical tension in pipes and their system components, e.g.
 - pumps
 - compressors
 - engines
- for muffling vibration and noise
- for compensating lateral movement
- to compensate for installation inaccuracies
- to compensate for ground and foundation settlement or tank settlement during filling

TIE ROD RESTRAINTS

- DN 25 – DN 150 Tie rods carried on silencing rubber sockets
- DN 200 – DN 300 Tie rods carried on spherical washers and conical seats

Materials

Standard: tie rods 8.8

Others: stainless steel

Corrosion protection

Standard: electrogalvanized

Others: hot-dip galvanized

CERTIFICATES

- CE (PED 2014/68/EU)
- Bureau Veritas
- DNV GL® / DNV®
- Lloyd's Register of Shipping
- TÜV Süd (KTA)
- Drinking water

DIMENSIONS STANDARD PROGRAM

DN	BL	Pressure rate	Ø di Bellows inner Ø	Ø C Raised face outer Ø	Ø E Raised face inner Ø	Ø W* Con-volution Ø	PN Flange connection EN 1092	Ø D Flange outer Ø	b Flange thickness	H Flange height
	mm	bar	mm	mm	mm	mm		mm	mm	mm
25	130	16	31 ± 3	72	39	88	16	115	16	210
32	130	16	31 ± 3	72	39	88	16	140	16	220
40	130	16	39 ± 3	81	45	96	16	150	16	230
50	130	16	49 ± 3	95	56	107	16	165	16	240
65	130	16	65 ± 3	115	72	123	16	185	18	260
80	130	16	77 ± 3	127	84	135	16	200	20	300
100	130	16	100 ± 3	151	109	160	16	220	20	350
125	130	16	127 ± 3	178	133	184	16	250	22	385
150	130	16	153 ± 3	206	161	212	16	285	22	420
200	130	10	202 ± 3	260	209	260	10	340	25	465
250	130	10	252 ± 3	313	262	313	10	395	25	520
300	130	10	303 ± 3	363	312	363	10	445	25	570

*unpressurized

From DN 200 higher pressure rate available on request.

MOVEMENT COMPENSATION / FLANGE VERSIONS

DN	Δ lat Lateral movement ± mm	Permissible vacuum w/o supporting ring at length BL bar absolute	Weight approx. kg
25	15	-	4.5
32	15	0.6	5.1
40	15	0.6	5.6
50	15	0.6	6.3
65	15	0.7	7.7
80	15	0.65	10.5
100	15	0.6	12.5
125	15	0.75	16.5
150	15	0.65	19.2
200	15	0.7	22.0
250	15	0.7	26.8
300	15	0.8	32.3

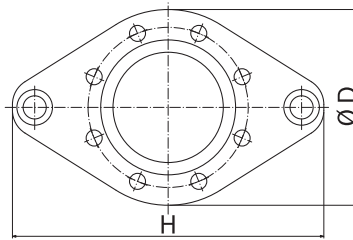

DN 25 - DN 150

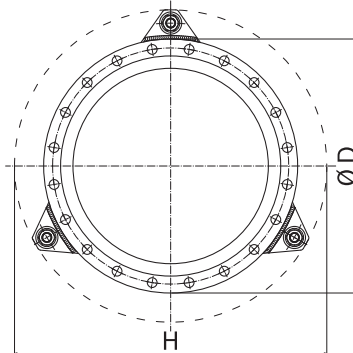

DN 200 - DN 300

Number of tie rods depending on pressure

ACCESSORIES

- Vacuum supporting ring
- Internal guide sleeve
- Flame-proof protective cover
- Protective hood
- Protective tube

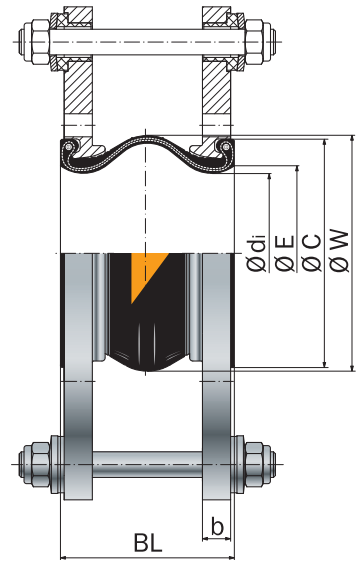

DN 25 - DN 150

Type R-2

Tie rods, external restraints, carried on silencing rubber sockets

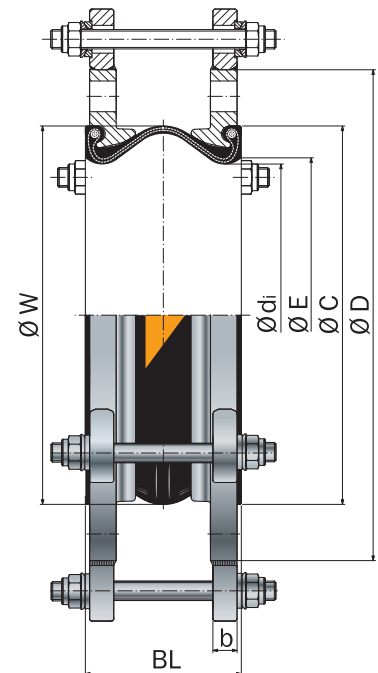

DN 200 - DN 300

Type R-2

Tie rods, external restraints, carried on spherical washers and conical seats

RUBBER EXPANSION JOINT TYPE GR-SAE

UNIVERSAL-EXPANSION JOINT DN 32 – DN 125



STRUCTURE TYPE GR-SAE / RUBBER BELLOWS PN 16

- Universal expansion joint consisting of a rubber bellows and rotatable flanges
- Elastic molded bellows
- High-tensile synthetic fibre reinforcement
- Wire-reinforced self-sealing rubber rim
- Electrical impedance 10^3 to 10^6 Ohm (DIN IEC 93, VDE 0303-30)

Rubber grade*	NBR
Colour code	red/yellow
Possible uses	hydrocarbon containing liquids

*Inquire about the resistance of the rubber grade depending on the kind of oil and additives.

Technical design	
Max. perm. operating pressure	16 bar*
Max. perm. temperature	+130 °C
Bursting pressure	≥ 48 bar
Vacuum operation	DN 32 – 50 without vacuum supporting ring, DN 65 – 125 with vacuum supporting ring

Max. operating pressure to be set 30 % lower for shock loads.

*Please consider a decrease of pressure due to temperature (see technical annex).

FLANGES / VERSIONS

- Rotatable flanges with stabilizing collar
- Flange drilling for through bolts according to SAE-standard, suitable for socket head cap screw acc. DIN 6912
- Special machined groove for rubber rim

	Standard	Others
Dimensions	SAE-standard 3000 psi	PN 16 according to EN 1092 Connection dimensions see technical annex page 213 – 215
Materials	aluminium	1.0038 (S235JR) etc.
Corrosion protection	not necessary for aluminium	electrogalvanized etc.

NOTE

Please comply with the general technical instructions regarding reaction force, moving force, fixed point load, installation instructions etc.

Subject to technical alterations and deviations resulting from the manufacturing process.

APPLICATIONS

- for reducing thermal and mechanical tension in pipes and their system components
- for compensating axial, lateral and angular movement
- for muffling vibration and oscillation at aggregates
- for damping noise transmission at
 - pumps
 - machines
 - fittings
- in hydraulic plants
- in lub oil lines
- mechanical engineering

CERTIFICATES

- CE (PED 2014/68/EU)

ACCESSORIES

- Vacuum supporting ring
- Internal guide sleeve
- Flame-proof protective cover
- Protective hood
- Protective tube

DIMENSIONS STANDARD PROGRAM

DN	BL	Pressure rate	$\varnothing d_i$ Bellows inner \varnothing mm	$\varnothing C$ Raised face outer \varnothing mm	$\varnothing E$ Raised face inner \varnothing mm	$\varnothing W$ Convolution \varnothing unpressurized mm
	mm	bar				
32	100	16	22 ± 3	51	30	55
40	130	16	28 ± 3	66	34	81
50	130	16	38 ± 3	76	44	91
65	130	16	48 ± 3	89	57	103
80	130	16	66 ± 3	106	74	118
100	130	16	90 ± 3	135	101	146
125	130	16	118 ± 4	161	130	170

MOVEMENT COMPENSATION

DN	Δax Axial movement		Δlat Lateral movement \pm mm	Δang Angular movement \pm \sphericalangle degrees	A* Effective bellows cross sectional area at 16 bar cm ²	Weight approx. kg
	Compression - mm	Elongation + mm				
32	20	10	10	25	0	0.4
40	20	10	10	20	38	0.5
50	20	10	10	20	46	0.7
65	20	10	10	15	62	0.8
80	20	10	10	12	76	1.1
100	20	10	10	8	109	1.5
125	20	10	10	8	165	1.8

Please inquire for simultaneous (different) movement.

*Effective bellows cross sectional area is a theoretical value.

FLANGE DIMS. ACCORDING TO SAE-STANDARD

DN	L ₁ mm	L ₂ mm	D ₁ mm	D ₂ mm	b mm	d mm
32	58,7	30,2	79	64	16	11
40	70	35,7	94	75	16	13
50	78	43,0	102	86	16	13
65	89	51,0	116	98	16	13
80	106	62,0	134	120	18	17
100	130	78,0	162	146	18	17
125	152	92,0	190	170	18	17

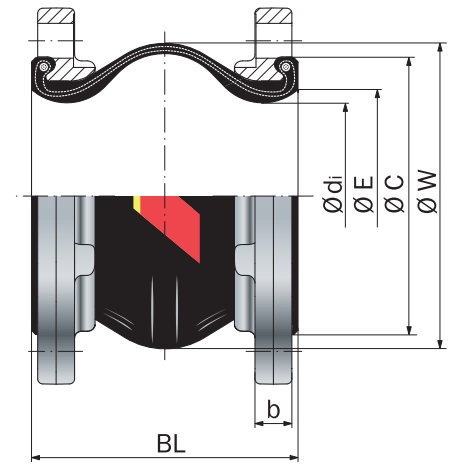

Type GR-SAE

Universal expansion joint

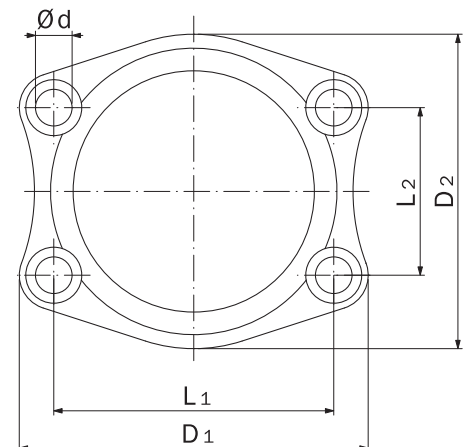

Flange according to SAE-standard

RUBBER EXPANSION JOINT TYPE RS-1

FLAME-PROOF

UNIVERSAL EXPANSION JOINT DN 25 – DN 300

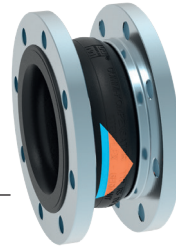

STRUCTURE TYPE RS-1 / RUBBER BELLOWS PN 16

- Universal-expansion joint, consisting of a flat-convoluted rubber bellows and rotatable flanges
- Flat-convoluted molded bellows in various rubber grades
- Steel wire cord reinforcement
- Wire-reinforced self-sealing rubber rim
- Electrical impedance < 100 Ohm (DIN IEC 93, VDE 0303-30)

Rubber grade*	EPDM	NBR
Colour code	orange/blue	red/blue
Possible uses	Hot water, acids, lyes	hydrocarbon containing liquids

*Check or inquire about the resistance of the rubber grade to temperature and medium.

Technical design	
Max. perm. operating pressure	16 bar*
Max. perm. temperature	+130 °C
Bursting pressure	≥ 50 bar
Vacuum operation	DN 20 – 50 without vacuum supporting ring, DN 65 – 300 with vacuum supporting ring

Max. operating pressure to be set 30 % lower for shock loads.

*Please consider a decrease of pressure due to temperature (see technical annex).

FLANGES / VERSIONS

- Rotable flanges with stabilizing collar
- Flange drilling for through bolts, DN 25 with Drill holes
- Special machined groove for rubber rim

	Standard	Others
Dimensions	EN 1092	ANSI, BS etc. Connection dimensions see technical annex page 213 – 215
Materials	1.0038 (S235JR)	1.4541, 1.4571 etc.
Corrosion protection	electrogalvanized	hot-dip galvanized, special varnish and coating, etc.

NOTE

Please comply with the general technical instructions regarding reaction force, moving force, fixed point load, installation instructions etc.

Subject to technical alterations and deviations resulting from the manufacturing process.

Chemicals used for water treatment (particularly in heating systems and coolant systems) can corrode the materials of the rubber expansion joint. According to VDI Directive 2035, the manufacturer of the chemicals must state that the data indicating that the materials used in the expansion joint, especially for the rubber bellows, will not be damaged by the chemicals.

APPLICATIONS

- for reducing thermal and mechanical tension in pipes and their system components, e.g.
 - pumps
 - compressors
 - engines
- for muffling vibrations and noise
 - at appliances
 - in cooling water and lub oil pipes
- for compensating axial, lateral and angular movement
- to compensate for installation inaccuracies
- to meet fire protection regulations
- shipbuilding industry
- in heating plants

CERTIFICATES

- CE (PED 2014/68/EU)
- Bureau Veritas
- DNV GL® / DNV®
- Lloyd's Register of Shipping
- TÜV/DIN 4809 (DN 25 – 200)
- American Bureau of Shipping
- MED
- TÜV Süd (KTA)

DIMENSIONS STANDARD PROGRAM

DN	BL	Pressure rate	Ø dj Bellows inner Ø	Ø C Raised face outer Ø	Ø E Raised face inner Ø	Ø W* Con- volution Ø	PN Flange connec- tion EN 1092	Ø D Flange outer Ø	b Flange thick- ness mm
	mm	bar	mm	mm	mm	mm		mm	mm
25	130	16	31 ± 3	72	39	88	16	115	16
32	130	16	31 ± 3	72	39	88	16	140	16
40	130	16	39 ± 3	81	45	96	16	150	16
50	130	16	49 ± 3	95	56	107	16	165	16
65	130	16	65 ± 3	115	72	123	16	185	18
80	130	16	77 ± 3	127	84	135	16	200	20
100	130	16	100 ± 3	151	109	160	16	220	20
125	130	16	127 ± 3	178	133	184	16	250	22
150	130	16	153 ± 3	206	161	212	16	285	22
200	130	16	202 ± 3	260	209	260	10	340	25
250	130	16	252 ± 3	313	262	313	10	395	25
300	130	16	303 ± 3	363	312	363	10	445	25

*unpressurized. From DN 200 pressure rate 16 bar also available with flanges PN 16.
Please contact us for further flange dimensions.

MOVEMENT COMPENSATION

DN	Δ ax Axial movement		Δ lat Lateral move- ment ± mm	Δ ang* Angular move- ment ± < degrees	A** Effective bellows cross sectional area at 16 bar cm ²	Permissible vacuum w/o supporting ring at length BL bar absolute	Weight approx. kg
	Compression - mm	Elongation + mm					
25	35	10	15	25	0	-	2.2
32	35	10	15	25	0	0	3.3
40	35	10	15	25	0	0.2	3.8
50	35	10	15	25	2	0.2	4.5
65	35	10	15	25	3	0.4	5.2
80	30	10	15	20	16	0.4	7.1
100	30	10	15	15	48	0.4	8.0
125	30	10	15	15	81	0.4	10.5
150	30	10	15	10	143	0.4	12.8
200	25	10	15	7	191	0.4	19.0
250	25	10	15	6	413	0.5	24.5
300	20	10	15	5	533	0.6	31.3

* Larger Δ ang possible for compressed installation length.

**Effective bellows cross sectional area is a theoretical value.

Please inquire for simultaneous (different) movement.

ACCESSORIES

- Vacuum supporting ring
- Internal guide sleeve
- Protective hood
- Protective tube

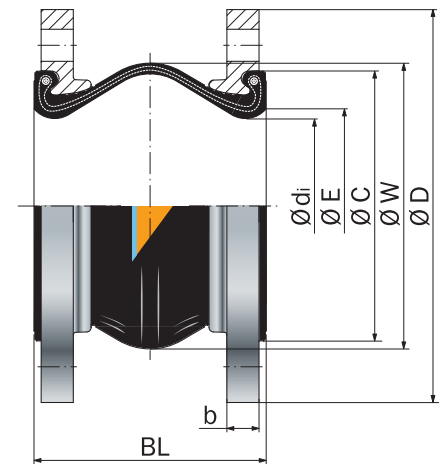

Type RS-1

Universal-expansion joint, without restraint

RUBBER EXPANSION JOINT TYPE RS-2

FLAME-PROOF

LATERAL EXPANSION JOINT

DN 25 – DN 300

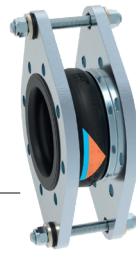

STRUCTURE TYPE RS-2 / RUBBER BELLOWS PN 16

- Lateral-expansion joint, consisting of a rubber bellows with rotatable flanges and tie rods (external restraints) to absorb reaction force from internal pressure
- Flat-convoluted molded bellows in various rubber grades
- Steel wire cord reinforcement
- Wire-reinforced self-sealing rubber rim
- Electrical impedance < 100 Ohm (DIN IEC 93, VDE 0303-30)

Rubber grade*	EPDM	NBR
Colour code	orange/blue	red/blue
Possible uses	Hot water, acids, lyes	hydrocarbon containing liquids

*Check or inquire about the resistance of the rubber grade to temperature and medium.

Technical design	
Max. perm. operating pressure	16 bar*
Max. perm. temperature	+130 °C
Bursting pressure	≥ 50 bar
Vacuum operation	DN 20 – 50 without vacuum supporting ring, DN 65 – 300 with vacuum supporting ring

Max. operating pressure to be set 30 % lower for shock loads.

*Please consider a decrease of pressure due to temperature (see technical annex).

FLANGES / VERSIONS

- Flanges with stabilizing collar and ears to carry the tie rods
- Flange drilling for through bolts, DN 25 with Drill holes
- Special machined groove for rubber rim

	Standard	Others
Dimensions	EN 1092	ANSI, BS etc. Connection dimensions see technical annex page 213 – 215
Materials	1.0038 (S235JR)	1.4541, 1.4571 etc.
Corrosion protection	electrogalvanized	hot-dip galvanized, special varnish and coating, etc.

NOTE

Please comply with the general technical instructions regarding reaction force, moving force, fixed point load, installation instructions etc.

Subject to technical alterations and deviations resulting from the manufacturing process.

Chemicals used for water treatment (particularly in heating systems and coolant systems) can corrode the materials of the rubber expansion joint.

According to VDI Directive 2035, and VGB R 455, the manufacturer of the chemicals must state the data indicating that the materials used in the expansion joint, especially for the rubber bellows, will not be damaged by the chemicals.

APPLICATIONS

- for reducing thermal and mechanical tension in pipes and their system components, e.g.
 - pumps
 - compressors
 - engines
- for muffling vibrations and noise
 - at appliances
 - in cooling water and lub oil pipes
- for compensating lateral movement
- to compensate for installation inaccuracies
- to meet fire protection regulations
- shipbuilding industry
- in heating plants

TIE ROD RESTRAINTS

- DN 25 – DN 150 Tie rods carried on silencing rubber sockets
- DN 200 – DN 300 Tie rods carried on spherical washers and conical seats

Materials

Standard: tie rods 8.8

Others: stainless steel

Corrosion protection

Standard: electrogalvanized

Others: hot-dip galvanized

DIMENSIONS STANDARD PROGRAM

DN	BL	Pressure rate	Ø dj Bellows inner Ø	Ø C Raised face outer Ø	Ø E Raised face inner Ø	Ø W* Con-volution Ø	PN Flange connection EN 1092	Ø D Flange outer Ø	b Flange thickness	H Flange height
	mm	bar	mm	mm	mm	mm		mm	mm	mm
25	130	16	31 ± 3	72	39	88	16	115	16	210
32	130	16	31 ± 3	72	39	88	16	140	16	220
40	130	16	39 ± 3	81	45	96	16	150	16	230
50	130	16	49 ± 3	95	56	107	16	165	16	240
65	130	16	65 ± 3	115	72	123	16	185	18	260
80	130	16	77 ± 3	127	84	135	16	200	20	300
100	130	16	100 ± 3	151	109	160	16	220	20	350
125	130	16	127 ± 3	178	133	184	16	250	22	385
150	130	16	153 ± 3	206	161	212	16	285	22	420
200	130	10	202 ± 3	260	209	260	10	340	25	465
250	130	10	252 ± 3	313	262	313	10	395	25	520
300	130	10	303 ± 3	363	312	363	10	445	25	570

*unpressurized

From DN 200 pressure rate 16 bar also available with flanges PN 16.
Please contact us for further flange dimensions.

MOVEMENT COMPENSATION / FLANGE VERSIONS

DN	Δ lat Lateral movement ± mm	Permissible vacuum w/o supporting ring at length BL bar absolute	Weight approx. kg
25	15	-	4.9
32	15	0	5.1
40	15	0.2	5.6
50	15	0.2	6.3
65	15	0.4	7.7
80	15	0.4	10.4
100	15	0.4	12.4
125	15	0.4	16.5
150	15	0.4	19.2
200	15	0.4	22.0
250	15	0.5	30.0
300	15	0.6	37.0

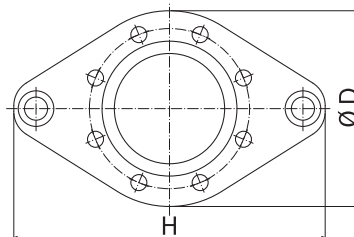

DN 25 - DN 150

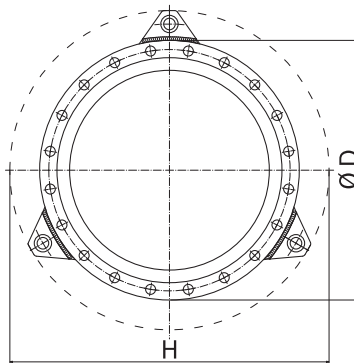

DN 200 - DN 300

Number of tie rods depending on pressure

CERTIFICATES

- CE (PED 2014/68/EU)
- Bureau Veritas
- DNV GL® / DNV®
- Lloyd's Register of Shipping
- TÜV/DIN 4809 (DN 25 - 200)
- TÜV Süd (KTA)
- MED
- American Bureau of Shipping

ACCESSORIES

- Vacuum supporting ring
- Internal guide sleeve
- Flame-proof protective cover
- Protective hood

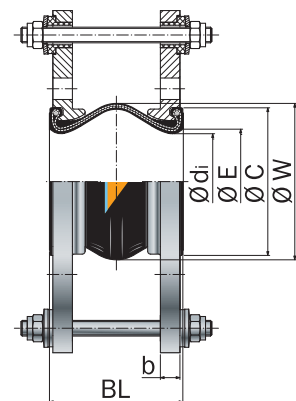

DN 25 - DN 150

Type RS-2

Tie rods, external restraints, carried on silencing rubber sockets

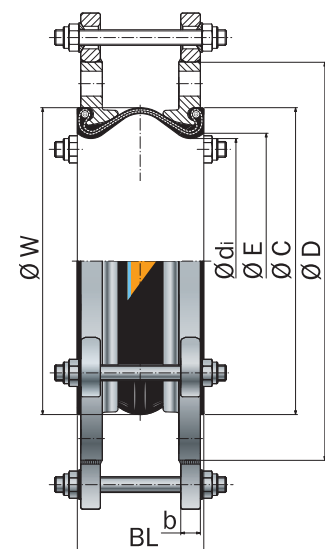

DN 200 - DN 300

Type RS-2

Tie rods, external restraints, carried on spherical washers and conical seats

RUBBER EXPANSION JOINT TYPE B-1

HIGHLY FLEXIBLE UNIVERSAL EXPANSION JOINT

DN 32 – DN 400

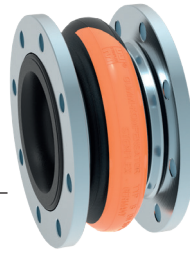

STRUCTURE TYPE B-1 / RUBBER BELLOWS PN 16

- Universal expansion joint consisting of a rubber bellows and rotatable flanges
- Very elastic molded bellows with specially deep convolution in various rubber grades
- Synthetic fibre reinforcement
- Wire-reinforced self-sealing rubber rim
- Electrical impedance 10^3 to 10^6 Ohm (DIN IEC 93, VDE 0303-30)

Rubber grade*	EPDM	NBR**
Colour code	orange	red
Possible uses	Hot water, acids, lyes	hydrocarbon containing liquids

*Check or inquire about the resistance of the rubber grade to temperature and medium.

**Only available in large lots.

Technical design	
Max. perm. operating pressure	16 bar*
Max. perm. temperature	+100 °C
Bursting pressure	≥ 48 bar
Vacuum operation	DN 32 – 40 without vacuum supporting ring, DN 50 – 400 with vacuum supporting ring

Max. operating pressure to be set 30 % lower for shock loads.

*Please consider a decrease of pressure due to temperature (see technical annex).

FLANGES / VERSIONS

- DN 32 – DN 150 rotatable flanges with stabilizing collar and drilling for through bolts
- DN 175 – DN 400 rotatable flanges drilled with threaded holes
- Special machined groove for rubber rim

	Standard	Others
Dimensions	EN 1092	ANSI, BS etc. Connection dimensions see technical annex page 213 – 215
Materials	1.0038 (S235JR)	1.4541, 1.4571 etc.
Corrosion protection	electrogalvanized	hot-dip galvanized, special varnish and coating, etc.

NOTE

Please comply with the general technical instructions regarding reaction force, moving force, fixed point load, installation instructions etc.

Subject to technical alterations and deviations resulting from the manufacturing process.

APPLICATIONS

- for compensating large axial and lateral movements
- for reducing thermal and mechanical tension in pipes and their system components, e.g.
 - pumps
 - compressors
- for muffling vibration and noise at appliances
- for compensating simultaneous movement in cooling water pipes
- to compensate for installation inaccuracies
- power station technology
- chemical industry

CERTIFICATES

- CE (PED 2014/68/EU)

ACCESSORIES

- Vacuum supporting ring
- Internal guide sleeve
- Flame-proof protective cover
- Protective hood
- Protective tube

DIMENSIONS STANDARD PROGRAM

DN	BL	Pressure rate	Ø dj Bellows inner Ø	Ø C Raised face outer Ø	Ø E Raised face inner Ø	Ø W* Con- volution Ø	PN Flange connection EN 1092	Ø D Flange outer Ø	b Flange thickness
	mm	bar	mm	mm	mm	mm		mm	mm
32	125	16	30 ± 3	75	42	100	16	150	16
40	125	16	30 ± 3	75	42	100	16	150	16
50	125	16	40 ± 3	86	61	115	16	165	16
65	125	16	61 ± 3	105	71	144	16	185	16
80	150	16	74 ± 3	118	82	167	16	200	18
100	150	16	92 ± 3	137	101	197	16	220	18
125	150	16	116 ± 3	166	130	230	16	250	18
150	150	16	139 ± 3	191	150	266	16	285	18
175	100	16	177 ± 3	217	183	282	16	315	18
200	125	10	201 ± 3	264	207	320	10	340	22
250	125	10	251 ± 3	314	260	374	10	395	23
300	150	10	302 ± 3	370	313	443	10	445	28
350	150	10	347 ± 3	424	354	485	10	505	28
400	150	10	392 ± 3	474	407	535	10	565	30

*unpressurized

From DN 200 pressure rate 16 bar also available with flanges PN 16.
Please contact us for further flange dimensions.

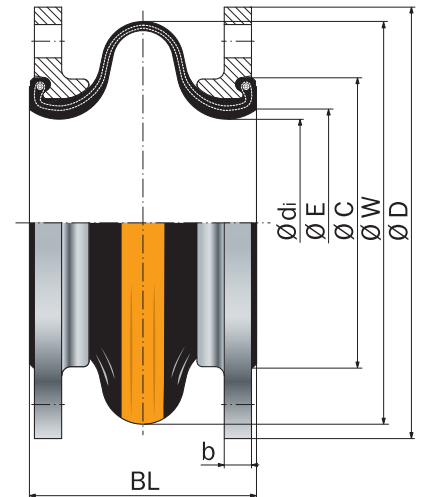

DN 32 - DN 150

Type B-1

Universal expansion joint without restraint, flanges with drilling for through bolts

MOVEMENT COMPENSATION

DN	Δ ax Axial movement		Δ lat Lateral movement ± mm	A* Effective bellows cross sectional area at 16 bar cm ²	Weight approx. kg
	Compression - mm	Elongation + mm			
32	25	15	15	21	4.0
40	25	15	15	21	4.4
50	30	15	15	30	4.3
65	35	20	15	55	4.9
80	45	20	20	90	5.7
100	45	25	20	150	7.2
125	45	35	25	220	9.5
150	45	35	25	330	10.4
175	25	40	25	432	13.6
200	35	40	35	553	17.0
250	35	40	35	730	21.3
300	45	50	35	975	29.5
350	45	50	35	1242	36.8
400	45	50	35	1600	47.9

*Effective bellows cross sectional area is a theoretical value.
Please inquire for simultaneous (different) movement.

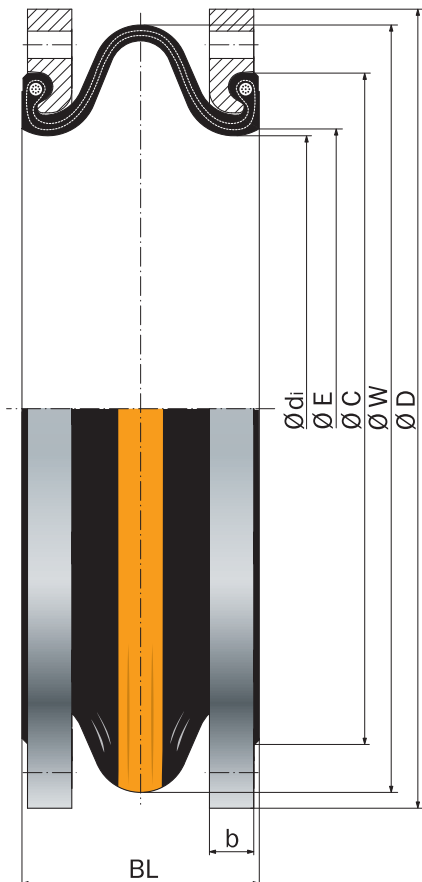

DN 175 - DN 400

Type B-1

Universal expansion joint without restraint, flanges drilled with threaded holes

RUBBER EXPANSION JOINT TYPE B-2, B-4

HIGHLY FLEXIBLE LATERAL EXPANSION JOINT

DN 32 – DN 400



STRUCTURE TYPE B-2, B-4 / RUBBER BELLOWS PN 16

- **Type B-2:** Lateral expansion joint consisting of a rubber bellows with rotatable flanges and tie rods (external restraints) to absorb reaction force from internal pressure
- **Type B-4:** Lateral expansion joint consisting of a rubber bellows with rotatable flanges and tie rods (external and internal restraints) to absorb reaction force from internal pressure or vacuum
- Very elastic molded bellows with specially high convolution in various rubber grades
- Synthetic fibre reinforcement
- Wire-reinforced self-sealing rubber rim
- Electrical impedance 10^3 to 10^6 Ohm (DIN IEC 93, VDE 0303-30)

Rubber grade*	EPDM	NBR**
Colour code	orange	red
Possible uses	Hot water, acids, lyes	hydrocarbon containing liquids

*Check or inquire about the resistance of the rubber grade to temperature and medium.

**Only available in large lots.

Technical design	
Max. perm. operating pressure	16 bar*
Max. perm. temperature	+100 °C
Bursting pressure	≥ 48 bar
Vacuum operation	DN 32 – 40 without vacuum supporting ring, DN 50 – 400 with vacuum supporting ring

Max. operating pressure to be set 30 % lower for shock loads.

*Please consider a decrease of pressure due to temperature (see technical annex).

FLANGES / VERSIONS

- DN 32 – DN 150 flanges with stabilizing collar and through bolts and with ears to carry the tie rods
- DN 175 – DN 400 flanges drilled with threaded holes and with segments to carry the tie rods
- Special machined groove for rubber rim

	Standard	Others
Dimensions	EN 1092	ANSI, BS etc. Connection dimensions see technical annex page 213 – 215
Materials	1.0038 (S235JR)	1.4541, 1.4571 etc.
Corrosion protection	electrogalvanized	hot-dip galvanized, special varnish and coating, etc.

NOTE

Please comply with the general technical instructions regarding reaction force, moving force, fixed point load, installation instructions etc.

Subject to technical alterations and deviations resulting from the manufacturing process.

APPLICATIONS

- for compensating large axial and lateral movements
- for reducing thermal and mechanical tension in pipes and their system components, e.g.
 - pumps
 - compressors
- for muffling vibration and noise at appliances
- to compensate for installation inaccuracies
- power engineering
- chemical industry

TIE ROD RESTRAINTS

- DN 32 – DN 150 Tie rods carried on silencing rubber sockets
- DN 175 – DN 400 Tie rods carried on spherical washers and conical seats

Materials

Standard: tie rods 8.8

Others: stainless steel

Corrosion protection

Standard: electrogalvanized

Others: hot-dip galvanized

CERTIFICATES

- CE (PED 2014/68/EU)

ACCESSORIES

- Vacuum supporting ring
- Internal guide sleeve
- Flame-proof protective cover
- Protective hood
- Protective tube

DIMENSIONS STANDARD PROGRAM

DN	BL	Pressure rate	Ø dj Bellows inner Ø	Ø C Raised face outer Ø	Ø E Raised face inner Ø	Ø W* Con-volution Ø	PN Flange connection EN 1092	Ø D Flange outer Ø	b Flange thickness	H Flange height
	mm	bar	mm	mm	mm	mm		mm	mm	mm
32	125	16	30 ± 3	75	42	100	16	150	16	230
40	125	16	30 ± 3	75	42	100	16	150	16	230
50	125	16	40 ± 3	86	61	115	16	165	16	240
65	125	16	61 ± 3	105	71	144	16	185	18	260
80	150	16	74 ± 3	118	82	167	16	200	20	300
100	150	16	92 ± 3	137	101	197	16	220	20	350
125	150	16	116 ± 3	166	130	230	16	250	22	385
150	150	16	139 ± 3	191	150	266	16	285	22	420
175	100	16	177 ± 3	217	183	282	16	315	22	437
200	125	10	201 ± 3	264	207	320	10	340	22	462
250	125	10	251 ± 3	314	260	374	10	395	23	517
300	150	10	302 ± 3	370	313	443	10	445	28	619
350	150	10	347 ± 3	424	354	485	10	505	28	679
400	150	10	392 ± 3	474	407	535	10	565	30	739

*unpressurized

Please contact us for further flange dimensions.

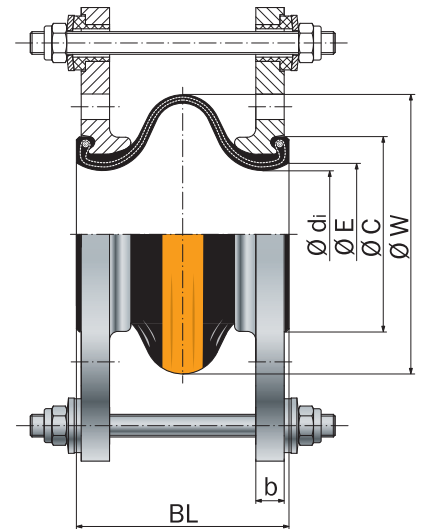

DN 32 - DN 150

Type B-2

DN 32 - DN 150 Tie rods, external restraints, carried in silencing sockets

DN 175 - DN 400 Tie rods, external restraints, carried in segments, on spherical washers and conical seats

MOVEMENT COMPENSATION / FLANGE VERSIONS

DN	Δ lat Lateral movement ± mm	Weight type B-2 approx. kg
32	15	6.2
40	15	6.2
50	15	6.2
65	15	7.7
80	20	10.6
100	20	13.3
125	25	18.5
150	25	22.5
175	25	24.0
200	35	25.1
250	35	25.9
300	35	48.1
350	35	57.5
400	35	69.4

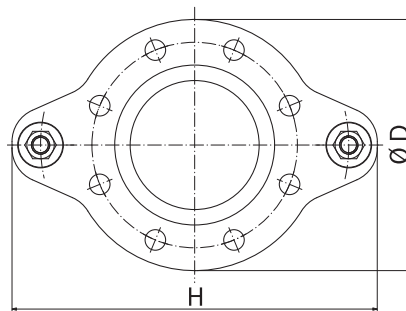

DN 32 - DN 150

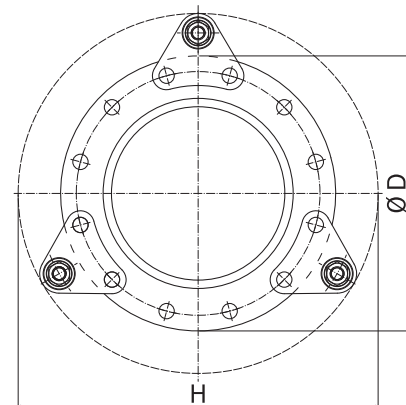

DN 175 - DN 400

Number of tie rods depending on pressure

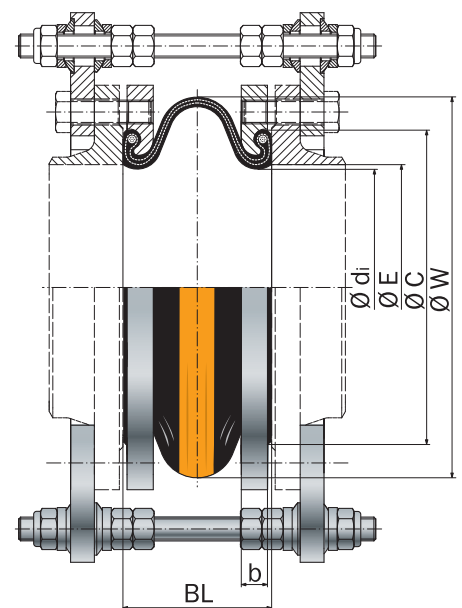

DN 175 - DN 400

Type B-4

DN 32 - DN 150 Tie rods, external and internal restraints, carried in silencing sockets

DN 175 - DN 400 Tie rods, external and internal restraints, carried in segments, on spherical washers and conical seats

RUBBER EXPANSION JOINT TYPE AG-5

UNIVERSAL-EXPANSION JOINT DN 20 – DN 50



STRUCTURE TYPE AG-5 / RUBBER BELLOWS PN 16

- Universal expansion joint consisting of a rubber bellows with threaded ends
- Male or female thread
- Combination of female/male thread
- Highly elastic molded bellows in various rubber grades
- Synthetic fibre reinforcement
- Electrical impedance 10^3 to 10^6 Ohm (DIN IEC 93, VDE 0303-30)

Rubber grade*	EPDM	NBR	CIIR
Colour code	orange	red	white
Possible uses	Hot water, acids, lyes	hydrocarbon containing liquids	Drinking water

*Check or inquire about the resistance of the rubber grade to temperature and medium.

Technical design	
Max. perm. operating pressure	16 bar*
Max. perm. temperature	+100 °C
Bursting pressure	≥ 48 bar

Max. operating pressure to be set 30 % lower for shock loads.

*Please consider a decrease of pressure due to temperature (see technical annex).

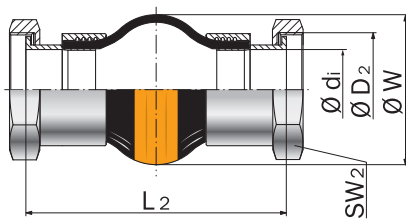

Type AG-5 with female thread union nut with flat gasket

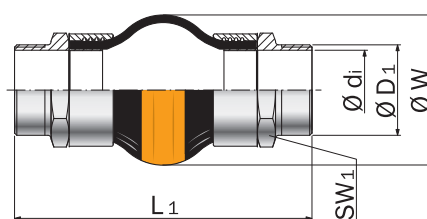

Type AG-5 with male thread

DIMENSIONS STANDARD PROGRAM

DN	L ₁	L ₂	Pressure rate	Ø di Bellows inner Ø	Ø W Convolution Ø unpressurized	Ø D ₁ Male thread Ø	Ø D ₂ Female thread Ø	SW ₁ Width across	SW ₂ Width across
	mm	mm	bar	mm	mm	inch	inch	mm	mm
20	200	172	16	20	60	R 3/4"	G 1"	30	36
25	200	172	16	26	67	R 1"	G 1 1/4"	36	46
32	200	172	16	33	80	R 1 1/4"	G 1 1/2"	46	55
40	200	172	16	40	87	R 1 1/2"	G 2"	55	65
50	200	172	16	52	99	R 2"	G 2 1/2"	65	80

NOTE

Please comply with the general technical instructions regarding reaction force, moving force, fixed point load, installation instructions etc.

Subject to technical alterations and deviations resulting from the manufacturing process.

APPLICATIONS

- for reducing thermal and mechanical tension
- for muffling vibration and noise
- for compensating axial, lateral and angular movement
- to compensate for installation inaccuracies
- domestic industry
- for heating plants and hot water pipes
- in oil hydraulic systems

CERTIFICATES

- CE (PED 2014/68/EU)
- Drinking water

THREADED ENDS/ VERSIONS

- Male thread acc. ISO 7-1 (DIN 2999).
- Union nut with female thread acc. ISO 228-1; flat sealing, suitable for drinking water

Materials

Standard: 1.4571

MOVEMENT COMPENSATION

DN	Δ ax Axial movement		Δ lat Lateral movement	Δ ang Angular movement	Weight
	Compression - mm	Elongation + mm	± mm	± < degrees	approx. kg
20	30	10	10	25	0.5
25	30	10	10	25	0.6
32	35	10	15	25	0.8
40	35	10	15	25	1.1
50	35	10	15	22	1.3

Please inquire for simultaneous (different) movement

RUBBER EXPANSION JOINT TYPE AS-5

UNIVERSAL-EXPANSION JOINT DN 32 - DN 40

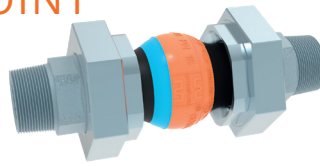

STRUCTURE TYPE AS-5 / RUBBER BELLOWS PN 16

- Universal expansion joint consisting of a rubber bellows with threaded ends
- Male or female thread
- Combination of female/male thread
- Highly elastic molded bellows in various rubber grades
- Steel wire cord reinforcement
- Electrical impedance 10^3 to 10^6 Ohm (DIN IEC 93, VDE 0303-30)

Rubber grade*	EPDM	NBR
Colour code	orange/blue	red/blau
Possible uses	Hot water, acids, lyes	hydrocarbon containing liquids

*Check or inquire about the resistance of the rubber grade to temperature and medium

Technical design	
Max. perm. operating pressure	16 bar*
Max. perm. temperature	+130 °C
Bursting pressure	≥ 50 bar
Vacuum operation	without vacuum supporting ring

Max. operating pressure to be set 30 % lower for shock loads.

*Please consider a decrease of pressure due to temperature (see technical annex).

THREADED ENDS / VERSIONS

- Male thread acc. ISO 7-1 (DIN 2999).
- Union nut with female thread acc. ISO 228-1; flat sealing.

	Standard
Materials	1.0038 (S235JR) (Malleable iron), electrogalvanized

DIMENSIONS STANDARD PROGRAM

DN	L ₁	L ₂	Pres- sure rate	Ø d _i Bellows inner Ø	Ø W Convolution Ø unpres- surized	Ø D ₁ Male thread Ø	Ø D ₂ Female thread Ø	SW ₁ Width across	SW ₂ Width across	SW ₃ Width across	Ø A Union nut Ø
	mm	mm	bar	mm	mm	inch	inch	mm	mm	mm	mm
32	237	187	16	34 ± 3	70	R 1¼"	G 1¼"	75	47	90	104
40	239	189	16	34 ± 3	70	R 1½"	G 1½"	75	54	90	104

NOTE

Please comply with the general technical instructions regarding reaction force, moving force, fixed point load, installation instructions etc.

Subject to technical alterations and deviations resulting from the manufacturing process.

APPLICATIONS

- for reducing thermal and mechanical tension
- for muffling vibration and noise
- for compensating axial, lateral and angular movement
- to compensate for installation inaccuracies
- for heating plants and hot water pipes

CERTIFICATES

- CE (PED 2014/68/EU)
- TÜV/DIN 4809

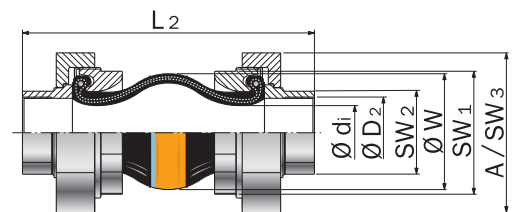

Type AS-5 with female thread

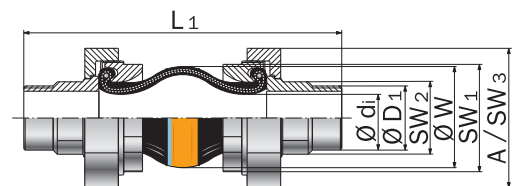

Type AS-5 with male thread

MOVEMENT COMPENSATION

DN	Δ ax Axial movement Compression - mm	Elongation + mm	Δ lat Lateral movement ± mm	Δ ang Angular movement ± < degrees	Weight approx. kg
32	30	10	15	25	2.4
40	30	10	15	25	2.6

Please inquire for simultaneous (different) movement

RUBBER EXPANSION JOINT TYPE E

CYLINDRICAL LATERAL EXPANSION JOINT

DN 20 – DN 250

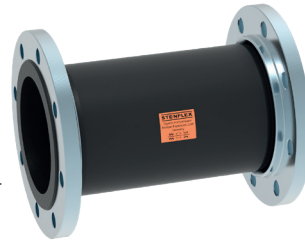

STRUCTURE TYPE E / RUBBER BELLOWS PN 10

- Lateral expansion joint consisting of a cylindrical rubber bellows without convolution and rotatable flanges
- Cylindrical bellows without convolution in various rubber grades
- Synthetic fibre reinforcement
- Wire-reinforced self-sealing rubber rim (type E)
- Electrical impedance 10^3 to 10^6 Ohm (DIN IEC 93, VDE 0303-30)

Rubber grade*	EPDM	NBR
Colour code	orange	red
Possible uses	Cooling, hot, waste, brackish water, acids, lyes	hydrocarbon containing liquids

*Check or inquire about the resistance of the rubber grade to temperature and medium.

Technical design	
Max. perm. operating pressure	10 bar*
Max. perm. temperature	+100 °C
Bursting pressure	≥ 30 bar
Vacuum operation	not suitable

Max. operating pressure to be set 30 % lower for shock loads.

*Please consider a decrease of pressure due to temperature (see technical annex).

FLANGES / VERSIONS

- Special machined groove for rubber rim
- Flange drilling for through bolts

	Standard	Others
Dimensions	EN 1092	ANSI, BS etc. Connection dimensions see technical annex page 213 – 215
Materials	1.0038 (S235JR)	stainless steel etc.
Corrosion protection	electrogalvanized	special varnish and coating, etc.

NOTE

Please comply with the general technical instructions regarding reaction force, moving force, fixed point load, installation instructions etc.

Reaction force, moving force and fixed point load have to be calculated as for universal expansion joints (no tie rod restraints available).

Subject to technical alterations and deviations resulting from the manufacturing process.

APPLICATIONS

- for compensating lateral movement
- to improve the flow of media (smooth passage)
- for deposit-free passage of solid matter, e.g. at pumps for gypsum suspension
- for muffling vibration and noise
- as cylindrical elastic transition piece at
 - pumps
 - pipelines
 - engines
 - ventilating fans/blowers
 - cooling water lines
- cement industry
- conveyance technology

SPECIAL VERSIONS

Other sizes or lengths on request

CERTIFICATES

- CE (PED 2014/68/EU)

DIMENSIONS STANDARD PROGRAM

DN	BL mm	Pressure rate bar	$\varnothing d_i$ Bellows inner \varnothing mm	$\varnothing C$ Raised face \varnothing mm	PN Flange connection EN 1092	$\varnothing D$ Flange outer \varnothing mm	b Flange thickness mm	Δ lat Lateral movement \pm mm	Weight approx. kg
20	160	10	25	51	16	115	16	30	2.3
25	160	10	25	51	16	115	16	30	2.3
32	200	10	39	72	16	140	16	25	3.4
40	200	10	45	81	16	150	16	25	3.9
50	230	10	56	95	16	165	16	25	4.7
65	290	10	72	115	16	185	18	20	5.8
80	310	10	84	127	16	200	20	20	7.9
100	350	10	109	151	16	220	20	20	9.2
125	350	10	133	178	16	250	22	20	12.1
150	350	10	161	206	16	285	22	20	14.7
200	350	10	209	260	10	340	25	15	21.3
250	350	10	262	313	10	395	25	15	26.3

Please contact us for further flange dimensions.

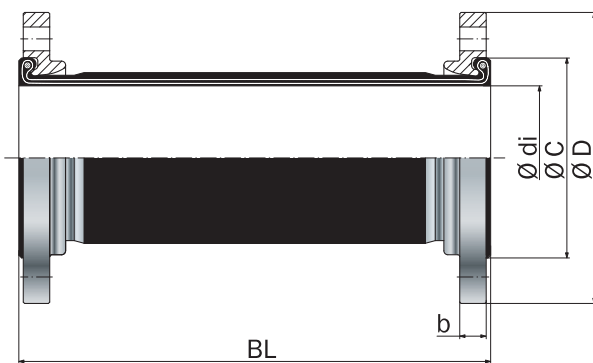

Type E

Cylindrical lateral expansion joint with rotatable flanges

RUBBER EXPANSION JOINT TYPE G

CONICAL

LATERAL EXPANSION JOINT

DN 25 – DN 250



STRUCTURE TYPE G / RUBBER BELLOWS PN 6, 10, 16

- Lateral expansion joint consisting of a conical rubber bellows without convolution and rotatable flanges
- Conical bellows without convolution in various rubber grades
- Synthetic fibre reinforcement
- Wire-reinforced self-sealing rubber rim
- Electrical impedance 10^3 to 10^6 Ohm (DIN IEC 93, VDE 0303-30)

Rubber grade*	EPDM	NBR
Colour code	orange	red
Possible uses	Cooling, hot, waste, brackish water, acids, lyes	hydrocarbon containing liquids

*Check or inquire about the resistance of the rubber grade to temperature and medium.

Technical design		
DN	DN 125:80 – DN 250:200	DN 40:25 – DN 100:80
Pressure rate	PN 10	PN 16
Max. perm. operating pressure	10 bar*	16 bar*
Max. perm. temperature	+100 °C	+100 °C
Bursting pressure	≥ 30 bar	≥ 48 bar
Vacuum operation	not suitable	

Max. operating pressure to be set 30 % lower for shock loads.

*Please consider a decrease of pressure due to temperature (see technical annex).

FLANGES / VERSIONS

- Special machined groove for rubber rim
- Flange drilling for through bolts

	Standard	Others
Dimensions	EN 1092	ANSI, BS etc. Connection dimensions see technical annex page 213 – 215
Materials	1.0038 (S235JR)	stainless steel etc.
Corrosion protection	electrogalvanized	hot-dip galvanized, special varnish and coating, etc.

NOTE

Please comply with the general technical instructions regarding reaction force, moving force, fixed point load, installation instructions etc.

Reaction force, moving force and fixed point load have to be calculated as for universal expansion joints (no tie rod restraints available).

Subject to technical alterations and deviations resulting from the manufacturing process.

APPLICATIONS

- for compensating lateral movement
- to improve the flow of media (smooth passage)
- for deposit-free passage of solid matter, e.g. at pumps for gypsum suspension
- for muffling vibration and noise
- as conical elastic transition piece at
 - pumps
 - pipelines
 - engines
 - ventilating fans/blowers
 - cooling water lines
- cement industry
- conveyance technology

SPECIAL VERSIONS

Other sizes or lengths on request

CERTIFICATES

- CE (PED 2014/68/EU)

DIMENSIONS STANDARD PROGRAM

DN	BL	Pressure rate	\varnothing di ₁ : \varnothing di ₂ Bellows inner \varnothing mm	\varnothing C ₁ : \varnothing C ₂ Raised face \varnothing mm	PN Flange connection EN 1092	\varnothing D ₁ : \varnothing D ₂ Flange outer \varnothing mm	b Flange thickness mm	Δ lat Lateral movement \pm mm	Weight approx. kg
40 : 25	250	16	45 : 30	81 : 51	16/16	150 : 115	16 : 16	30	3.2
40 : 32	250	16	45 : 39	81 : 72	16/16	150 : 140	16 : 16	30	3.7
50 : 32	250	16	56 : 39	95 : 72	16/16	165 : 140	16 : 16	30	4.1
50 : 40	250	16	56 : 45	95 : 81	16/16	165 : 150	16 : 16	30	4.4
65 : 40	250	16	72 : 45	115 : 81	16/16	185 : 150	18 : 16	30	5.2
65 : 50	250	16	72 : 56	115 : 95	16/16	185 : 165	18 : 16	30	5.6
80 : 50	250	16	84 : 56	127 : 95	16/16	200 : 165	20 : 16	30	6.3
80 : 65	250	16	84 : 72	127 : 115	16/16	200 : 185	20 : 18	30	7.1
100 : 65	250	16	109 : 72	151 : 115	16/16	220 : 185	20 : 18	30	7.5
100 : 80	250	16	109 : 84	151 : 127	16/16	220 : 200	20 : 20	25	8.2
125 : 80	250	10	133 : 84	178 : 127	16/16	250 : 200	22 : 20	25	9.7
125 : 100	250	10	133 : 109	178 : 151	16/16	250 : 220	22 : 20	25	10.0
150 : 80	250	10	161 : 84	206 : 127	16/16	285 : 200	22 : 20	25	10.9
150 : 100	250	10	161 : 109	206 : 151	16/16	285 : 220	22 : 20	25	11.4
150 : 125	250	10	161 : 133	206 : 178	16/16	285 : 250	22 : 22	25	12.8
200 : 125	250	10	209 : 133	260 : 178	10/16	340 : 250	25 : 22	25	16.0
200 : 150	250	10	209 : 161	260 : 206	10/16	340 : 285	25 : 22	25	17.2
250 : 150	250	10	262 : 161	313 : 206	10/16	395 : 285	25 : 22	25	19.3
250 : 200	250	10	262 : 209	313 : 260	10/10	395 : 340	25 : 25	25	22.4

Please contact us for further flange dimensions.

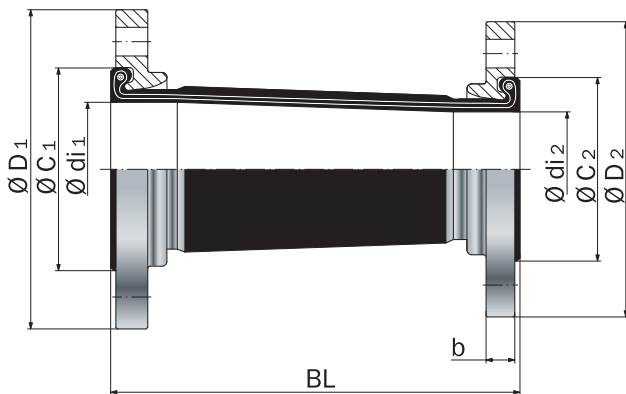

Type G

Conical lateral expansion joint with rotatable flanges

RUBBER EXPANSION JOINT TYPE C-1

UNIVERSAL EXPANSION JOINT DN 300 – DN 3600



STRUCTURE TYPE C-1 / RUBBER BELLOWS PN 4, 10, 16

- Universal expansion joint consisting of a rubber bellows and press-on retaining flanges
- Available in various bellow's geometries and special lengths
- Elastic robust bellows in various rubber grades
- Synthetic fibre reinforcement
- Full-faced self-sealing rubber flanges with drilling for through bolts
- Electrical impedance 10^3 to 10^6 Ohm (DIN IEC 93, VDE 0303-30)

Rubber grade*	EPDM	NBR	CIIR
Colour code	orange	red	white
Possible uses	Cooling, sea, brackish water, acids, lyes	hydrocarbon containing liquids	Drinking water

*Check or inquire about the resistance of the rubber grade to temperature and medium.

Technical design			
DN	DN 300 – 3600	DN 300 – 2800	DN 300 – 2400
Pressure rate	PN 4	PN 10	PN 16
Max. perm. operating pressure	4 bar*	10 bar*	16 bar*
Max. perm. temperature	+100 °C	+100 °C	+100 °C
Bursting pressure	≥ 15 bar	≥ 30 bar	≥ 48 bar
Vacuum operation	with vacuum supporting ring (at permanent vacuum)		

Max. operating pressure to be set 30 % lower for shock loads.

*Please consider a decrease of pressure due to temperature (see technical annex).

FLANGES / VERSIONS

- Press-on retaining flanges with stabilizing collar
- Flange drilling for through bolts

	Standard	Others
Dimensions	EN 1092	ANSI, BS etc. Connection dimensions see technical annex page 213 – 215
Materials	1.0038 (S235JR)	1.0577 (S355J2), 1.4541, 1.4571 etc.
Corrosion protection	hot dip galvanized	special varnish and coating, etc.

NOTE

Please comply with the general technical instructions regarding reaction force, moving force, fixed point load, installation instructions etc.

Subject to technical alterations and deviations resulting from the manufacturing process.

APPLICATIONS

- for reducing thermal and mechanical tension in pipes and their system components, e.g.
 - pumps
 - condensers
- for compensating axial, lateral and angular movement
- for compensating simultaneous movement in cooling water pipes
- to compensate for installation inaccuracies
- to compensate for ground and foundation settlement
- as installation and dismantling aid
- power station technology
- process plant engineering

CERTIFICATES

- CE (PED 2014/68/EU)
- Drinking water
- TÜV Süd (KTA)

ACCESSORIES

- Vacuum supporting ring
- Internal guide sleeve
- Protective tube

DIMENSIONS STANDARD PROGRAM

DN	Pressure rate bar	Bellows		Steel flange			w/o vacuum supporting ring			with vacuum supporting ring		
		Ø d _i Bellows inner Ø tolerance ±1% mm	h Rubber flange thick- ness mm	Ø D Flange outer Ø PN 6 (EN 1092) mm	Ø D Flange outer Ø PN 10 (EN 1092) mm	b Flange thick- ness mm	BL mm	Ø W Convolution Ø unpressurized mm	Weight approx. kg	BL mm	Ø W Convolution Ø unpressurized mm	Weight approx. kg
300	4/10/16	300	15	440	445	20	250	413	34	250	413	40
350	4/10/16	350	15	490	505	20	250	463	38	250	463	45
400	4/10/16	400	15	540	565	20	250	513	43	250	513	55
450	4/10/16	450	15	595	615	20	250	563	54	250	563	60
500	4/10/16	500	15	645	670	20	250	613	59	250	613	65
600	4/10/16	600	15	755	780	20	250	713	80	250	713	80
700	4/10/16	700	15	860	895	20	250	813	93	250	813	95
750	4/10/16	750	15	925	965	20	250	863	103	250	863	115
800	4/10/16	800	20	975	1015	20	250	923	118	250	923	130
900	4/10/16	900	20	1075	1115	20	250	1023	131	250	1023	145
1000	4/10/16	1000	20	1175	1230	20	250	1123	160	250	1123	165
1100	4/10/16	1100	20	1290	1345	20	300	1268	185	325	1310	210
1200	4/10/16	1200	20	1405	1455	20	300	1368	215	325	1410	240
1300	4/10/16	1300	20	1520	1565	20	300	1468	230	325	1510	255
1400	4/10/16	1400	20	1630	1675	20	300	1568	260	325	1610	290
1500	4/10/16	1500	20	1730	1795	20	300	1668	295	325	1710	325
1600	4/10/16	1600	20	1830	1915	20	300	1768	340	325	1810	380
1700	4/10/16	1700	20	1940	2015	20	300	1868	365	325	1910	400
1800	4/10/16	1800	20	2045	2115	20	300	1968	370	325	2010	410
2000	4/10/16	2000	20	2265	2325	20	300	2168	430	325	2210	460
2100	4/10/16	2100	20	2375	2440	20	300	2268	475	325	2310	515
2200	4/10/16	2200	25	2475	2550	20	300	2378	525	325	2420	575
2300	4/10/16	2300	25	2590	2650	20	300	2478	550	325	2520	600
2400	4/10/16	2400	25	2685	2760	20	300	2578	600	325	2620	650
2500	4/10	2500	25	2795	2860	20	300	2678	620	325	2720	670
2600	4/10	2600	25	2905	2960	20	300	2778	640	325	2820	690
2800	4/10	2800	25	3115	3180	20	300	2978	690	325	3020	730
3000	4	3000	25	3315	3405	20	300	3178	720	325	3220	770
3200	4	3200	25	3525	-	20	300	3378	740	325	3420	790
3400	4	3400	25	3735	-	20	300	3578	770	325	3620	820
3600	4	3600	25	3975	-	20	300	3778	820	325	3820	870

Other lengths (BL) and pressure rates on request. Please contact us for further flange dimensions.

MOVEMENT COMPENSATION

DN	w/o vacuum supporting ring					with vacuum supporting ring				
	Δ ax Axial movement		Δ lat Lateral movement ±mm	Δ ang Angular movement ±\angle degrees	A* Effective bellows cross sectional area cm ²	Δ ax Axial movement		Δ lat Lateral movement ±mm	Δ ang Angular movement ±\angle degrees	A* Effective bellows cross sectional area cm ²
	Compression -mm	Elongation +mm				Compression -mm	Elongation +mm			
300	40	30	30	11.3	1020	40	30	30	5.5	1020
350	40	30	30	9.7	1300	40	30	30	4.8	1300
400	40	30	30	8.5	1620	40	30	30	4.2	1620
450	40	30	30	7.7	1970	40	30	30	3.8	1970
500	40	30	30	6.9	2360	40	30	30	3.4	2360
600	40	30	30	5.7	3240	40	30	30	2.8	3240
700	40	30	30	4.9	4250	40	30	30	2.5	4250
750	40	30	30	4.6	4820	40	30	30	2.3	4820
800	40	30	30	4.3	5410	40	30	30	2.1	5410
900	40	30	30	3.8	6700	40	30	30	1.9	6700
1000	40	30	30	3.4	8140	40	30	30	1.7	8140
1100	40	30	30	3.2	10500	60	35	35	3.6	11200
1200	40	30	30	2.9	12300	60	35	35	3.3	13000
1300	40	30	30	2.7	14200	60	35	35	3.0	15000
1400	40	30	30	2.5	16300	60	35	35	2.8	17100
1500	40	30	30	2.3	18500	60	35	35	2.6	19300
1600	40	30	30	2.2	20800	60	35	35	2.5	21700
1700	40	30	30	2.0	23300	60	35	35	2.3	24300
1800	40	30	30	1.9	25900	60	35	35	2.2	26900
2000	40	30	30	1.7	31500	60	35	35	2.0	32700
2100	40	30	30	1.6	34500	60	35	35	1.9	35800
2200	40	30	30	1.6	37700	60	35	35	1.8	39000
2300	40	30	30	1.5	41000	60	35	35	1.7	42300
2400	40	30	30	1.4	44500	60	35	35	1.6	45800
2500	40	30	30	1.4	48000	60	35	35	1.6	49500
2600	40	30	30	1.3	51800	60	35	35	1.5	53300
2800	40	30	30	1.2	59600	60	35	35	1.4	61200
3000	40	30	30	1.1	68000	60	35	35	1.3	69700
3200	40	30	30	1.0	77000	60	35	35	1.2	78800
3400	40	30	30	1.0	86500	60	35	35	1.1	88500
3600	40	30	30	1.0	96600	60	35	35	1.1	98600

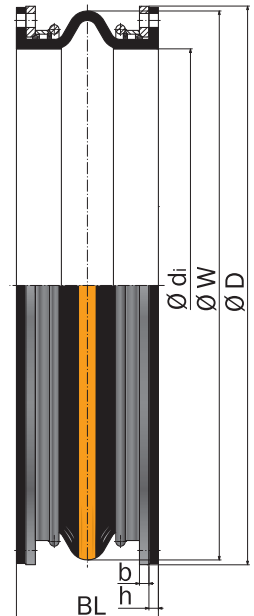

Type C-1

Universal expansion joint without restraints

Please inquire for simultaneous (different) movement.

*Effective bellows cross sectional area is a theoretical value.

RUBBER EXPANSION JOINT TYPE C-2

HIGHLY FLEXIBLE TWIN-CONVOLUTED UNIVERSAL EXPANSION JOINT

DN 300 – DN 3600



STRUCTURE TYPE C-2 / RUBBER BELLOWS PN 4, 10

- Universal expansion joint consisting of a rubber bellows and press-on retaining flanges
- Outer stabilizing ring between the convolutions
- Available in special lengths
- Twin-convoluted very elastic robust bellows in various rubber grades
- Synthetic fibre reinforcement
- Full-faced self-sealing rubber flanges with drilling for through bolts
- Electrical impedance 10^3 to 10^6 Ohm (DIN IEC 93, VDE 0303-30)

Rubber grade*	EPDM	NBR	CIIR
Colour code	orange	red	white
Possible uses	Cooling, sea, brackish water, acids, lyes	hydrocarbon containing liquids	Drinking water

*Check or inquire about the resistance of the rubber grade to temperature and medium.

Technical design		
DN	DN 300 – 2000	DN 300 – 2000
Pressure rate	PN 4	PN 10
Max. perm. operating pressure	4 bar*	10 bar*
Max. perm. temperature	+100 °C	+100 °C
Bursting pressure	≥ 12 bar	≥ 30 bar
Vacuum operation	Vacuum supporting rings on request (only for horizontal installation)	

Max. operating pressure to be set 30 % lower for shock loads.

*Please consider a decrease of pressure due to temperature (see technical annex).

FLANGES / VERSIONS

- Press-on retaining flanges with stabilizing collar
- Flange drilling for through bolts

	Standard	Others
Dimensions	EN 1092	ANSI, BS etc. Connection dimensions see technical annex page 213 – 215
Materials	1.0038 (S235JR)	1.0577 (S355J2), 1.4541, 1.4571 etc.
Corrosion protection	hot-dip galvanized	special varnish and coating, electrogalvanized, etc.

NOTE

For vertical installation please consult us for technical advice.

Please comply with the general technical instructions regarding reaction force, moving force, fixed point load, installation instructions etc.

Subject to technical alterations and deviations resulting from the manufacturing process.

APPLICATIONS

- for compensating large axial, lateral and angular movement
- for reducing thermal and mechanical tension in pipes and their system components, e.g.
 - pumps
 - fittings
 - condensers
- for compensating simultaneous movement in cooling water pipes
- to compensate for installation inaccuracies
- to compensate for ground and foundation settlement
- power station technology
- process plant engineering

CERTIFICATES

- CE (PED 2014/68/EU)
- Drinking water
- TÜV Süd (KTA)

ACCESSORIES

- Vacuum supporting ring
- Internal guide sleeve
- Protective tube

DIMENSIONS STANDARD PROGRAM

DN	Pressure rate bar	Bellows		Steel flange			w/o vacuum supporting ring			with vacuum supporting ring		
		Ø di Bellows inner Ø tolerance ±1% mm	h Rubber flange thickness mm	Ø D Flange outer Ø PN 6 (EN 1092) mm	Ø D Flange outer Ø PN 10 (EN 1092) mm	b Flange thick- ness mm	BL mm	Ø W Convolution Ø unpressurized mm	Weight approx. kg	BL mm	Ø W Convolution Ø unpressurized mm	Weight approx. kg
300	4/10	300	15	440	445	20	400	413	35	400	413	40
350	4/10	350	15	490	505	20	400	463	45	400	463	50
400	4/10	400	15	540	565	20	400	513	55	400	513	60
450	4/10	450	15	595	615	20	400	563	60	400	563	65
500	4/10	500	15	645	670	20	400	613	65	400	613	70
600	4/10	600	15	755	780	20	400	713	80	400	713	85
700	4/10	700	15	860	895	20	400	813	100	400	813	105
750	4/10	750	15	925	965	20	400	863	115	400	863	120
800	4/10	800	20	975	1015	20	400	923	130	400	923	135
900	4/10	900	20	1075	1115	20	400	1023	150	400	1023	155
1000	4/10	1000	20	1175	1230	20	400	1123	170	400	1123	175
1100	4/10	1100	20	1290	1345	20	525	1268	220	550	1310	280
1200	4/10	1200	20	1405	1455	20	525	1368	240	550	1410	310
1300	4/10	1300	20	1520	1565	20	525	1468	280	550	1510	350
1400	4/10	1400	20	1630	1675	20	525	1568	320	550	1610	400
1500	4/10	1500	20	1730	1795	20	525	1668	360	550	1710	450
1600	4/10	1600	20	1830	1915	20	525	1768	400	550	1810	490
1700	4/10	1700	20	1940	2015	20	525	1868	415	550	1910	520
1800	4/10	1800	20	2045	2115	20	525	1968	430	550	2010	540
2000	4/10	2000	20	2265	2325	20	525	2168	460	550	2210	620
2100		2100	20	2375	2440	20	525	2268		550	2310	
2200		2200	25	2475	2550	20	525	2378		550	2420	
2300		2300	25	2590	2650	20	525	2478		550	2520	
2400		2400	25	2685	2760	20	525	2578		550	2620	
2500		2500	25	2795	2860	20	525	2678		550	2720	
2600		2600	25	2905	2960	20	525	2778		550	2820	
2800		2800	25	3115	3180	20	525	2978		550	3020	
3000		3000	25	3315	3405	20	525	3178		550	3220	
3200		3200	25	3525	-	20	525	3378		550	3420	
3400		3400	25	3735	-	20	525	3578		550	3620	
3600		3600	25	3975	-	20	525	3778		550	3820	

Other lengths (BL) and pressure rates on request. Please contact us for further flange dimensions.

MOVEMENT COMPENSATION

DN	w/o vacuum supporting ring					with vacuum supporting ring				
	Δ ax Axial movement		Δ lat Lateral movement	Δ ang Angular movement	A* Effective bellows cross sectional area	Δ ax Axial movement		Δ lat Lateral movement	Δ ang Angular movement	A* Effective bellows cross sectional area
	Compression -mm	Elongation +mm	±mm	± \sphericalangle degrees	cm ²	Compression -mm	Elongation +mm	±mm	± \sphericalangle degrees	cm ²
300	80	60	50	21.8	1020	80	60	50	10.0	1020
350	80	60	50	18.9	1300	80	60	50	9.0	1300
400	80	60	50	16.7	1620	80	60	50	8.0	1620
450	80	60	50	15.0	1970	80	60	50	7.0	1970
500	80	60	50	13.5	2360	80	60	50	6.0	2360
600	80	60	50	11.3	3240	80	60	50	5.5	3240
700	80	60	50	9.8	4250	80	60	50	5.0	4250
750	80	60	50	9.1	4820	80	60	50	4.5	4820
800	80	60	50	8.6	5410	80	60	50	4.0	5410
900	80	60	50	7.6	6700	80	60	50	3.5	6700
1000	80	60	50	6.9	8140	80	60	50	3.5	8140
1100	80	60	50	6.5	10500	80	60	50	7.3	11200
1200	80	60	50	5.9	12300	80	60	50	6.7	13000
1300	80	60	50	5.5	14200	80	60	50	6.2	15000
1400	80	60	50	5.1	16300	80	60	50	5.7	17100
1500	80	60	50	4.9	18500	80	60	50	5.4	19300
1600	80	60	50	4.5	20800	80	60	50	5.0	21700
1700	80	60	50	4.1	23300	80	60	50	4.7	24300
1800	80	60	50	3.9	25900	80	60	50	4.5	26900
2000	80	60	50	3.7	31500	80	60	50	4.0	32700
2100	80	60	50	3.3	34500	80	60	50	3.8	35800
2200	80	60	50	3.2	37700	80	60	50	3.7	39000
2300	80	60	50	3.1	41000	80	60	50	3.5	42300
2400	80	60	50	3.0	44500	80	60	50	3.4	45800
2500	80	60	50	2.9	48000	80	60	50	3.2	49500
2600	80	60	50	2.7	51800	80	60	50	3.1	53300
2800	80	60	50	2.5	59600	80	60	50	2.9	61200
3000	80	60	50	2.4	68000	80	60	50	2.7	69700
3200	80	60	50	2.3	77000	80	60	50	2.5	78800
3400	80	60	50	2.2	86500	80	60	50	2.4	88500
3600	80	60	50	2.1	96600	80	60	50	2.3	98600

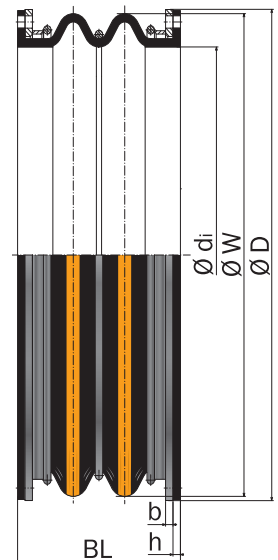

Type C-2

Highly flexible universal expansion joint without restraint

Please inquire for simultaneous (different) movement.

*Effective bellows cross sectional area is a theoretical value.

CUSTOMIZED PRODUCTION

RUBBER EXPANSION JOINT TYPE C-31

LATERAL EXPANSION JOINT DN 300 – DN 3600



STRUCTURE TYPE C-31 / RUBBER BELLOWS PN 4, 10, 16

- Lateral expansion joint consisting of a rubber bellows and press-on retaining flanges and tie rods
- Tie rods (external restraints) to absorb reaction force from internal pressure
- Alternative: Tie rods (external and internal restraints) to absorb reaction force from internal pressure or vacuum
- Available in various bellows geometries and special lengths
- Elastic robust bellows in various rubber grades
- Synthetic fibre reinforcement
- Full-faced self-sealing rubber flanges with drilling for through bolts
- Electrical impedance 10^3 to 10^6 Ohm (DIN IEC 93, VDE 0303-30)

Rubber grade*	EPDM	NBR	CIIR
Colour code	orange	red	white
Possible uses	Cooling, sea, brackish water, acids, lyes	hydrocarbon containing liquids	Drinking water

*Check or inquire about the resistance of the rubber grade to temperature and medium.

Technical design			
DN	DN 300 – 2400	DN 300 – 1000	DN 300 – 1000
Pressure rate	PN 4	PN 10	PN 16
Max. perm. operating pressure	4 bar*	10 bar*	16 bar*
Max. perm. temperature	+100 °C	+100 °C	+100 °C
Bursting pressure	≥ 15 bar	≥ 30 bar	≥ 48 bar
Vacuum operation	with vacuum supporting ring (at permanent vacuum)		

Max. operating pressure to be set 30 % lower for shock loads.

*Please consider a decrease of pressure due to temperature (see technical annex).

FLANGES / VERSIONS

- Press-on retaining flanges with stabilizing collar
- With ears or with second bolt circle to carry the tie rods (depending on DN and PN)
- Flange drilling for through bolts

	Standard	Others
Dimensions	EN 1092	ANSI, BS etc. Connection dimensions see technical annex page 213 – 215
Materials	1.0038 (S235JR) 1.0577 (S355J2)	stainless steel etc.
Corrosion protection	hot-dip galvanized	special varnish and coating, etc.

NOTE

Please comply with the general technical instructions regarding reaction force, moving force, fixed point load, installation instructions etc.

Subject to technical alterations and deviations resulting from the manufacturing process.

APPLICATIONS

- for compensating lateral movement
- for reducing thermal and mechanical tension in pipes and their system components, e.g.
 - pumps
 - condensers
- to compensate for installation inaccuracies
- to compensate for ground and foundation settlement
- as installation and dismantling aid
- power station technology
- process plant engineering

TIE ROD RESTRAINTS

- Tie rods carried on spherical washers and conical seats

Materials

Standard: tie rods 8.8

Others: stainless steel

Corrosion protection

Standard: hot-dip galvanized

Others: special coating, etc.

CERTIFICATES

- CE (PED 2014/68/EU)
- Drinking water
- TÜV Süd (KTA)

ACCESSORIES

- Vacuum supporting ring
- Internal guide sleeve
- Protective tube

DIMENSIONS STANDARD PROGRAM

DN	Pressure rate bar	Bellows		without vacuum supporting ring					with vacuum supporting ring				
		Ø di Bellows inner Ø tolerance ±1% mm	h Rubber- flange thickness mm	BL mm at rated pressure			Ø W Convolution Ø unpressuri- zed mm	Weight approx. kg	BL mm at rated pressure			Ø W Convolution Ø unpressuri- zed mm	Weight approx. kg
				4bar	10 bar	16 bar			4bar	10 bar	16 bar		
300	4/10/16	300	15	250	250	250	413	86	250	250	250	413	92
350	4/10/16	350	15	250	250	250	463	100	250	250	250	463	108
400	4/10/16	400	15	250	250	250	513	118	250	250	250	513	121
450	4/10/16	450	15	250	250	250	563	132	250	250	250	563	137
500	4/10/16	500	15	250	250	275	613	144	250	250	275	613	149
600	4/10/16	600	15	250	250	275	713	173	250	250	275	713	205
700	4/10/16	700	15	250	275	275	813	255	250	275	275	813	263
750	4/10/16	750	15	250	275	300	863	294	250	275	300	863	343
800	4/10/16	800	20	275	275	300	923	357	275	275	300	923	363
900	4/10/16	900	20	275	300	325	1023	397	275	300	325	1023	453
1000	4/10/16	1000	20	275	300	325	1123	539	275	300	325	1123	555
1100	4	1100	20	325			1268	545	325			1310	565
1200	4	1200	20	350			1368	665	350			1410	715
1300	4	1300	20	350			1468	800	350			1510	830
1400	4	1400	20	350			1568	970	350			1610	1005
1500	4	1500	20	350			1668	1070	350			1710	1210
1600	4	1600	20	350			1768	1300	350			1810	1340
1700	4	1700	20	350			1868	1360	375			1910	1515
1800	4	1800	20	350	on request	on request	1968	1530	375	on request	on request	2010	1575
2000	4	2000	20	375			2168	1875	375			2210	1935
2100	4	2100	20	375	on request	on request	2268	2115	375	on request	on request	2310	2175
2200	4	2200	25	375	on request	on request	2378	2435	400	on request	on request	2420	2495
2300	4	2300	25	375			2478	2645	400			2520	2605
2400	4	2400	25	375			2578	2865	400			2620	2940

Values are based on flange dimensions according to EN 1092 PN 10. Please contact us for further flange dimensions.
Lengths (BL) may vary and depend on flange drilling, operating pressure, possible vacuum, operating temperature.
Larger sizes (DN) on request.

MOVEMENT COMPENSATION / VERSIONS

DN	without vacuum supporting ring	with vacuum supporting ring
	Δ lat Lateral movement ±mm	Δ lat Lateral movement ±mm
300	30	30
350	30	30
400	30	30
450	30	30
500	30	30
600	30	30
700	30	30
750	30	30
800	30	30
900	30	30
1000	30	30
1100	30	35
1200	30	35
1300	30	35
1400	30	35
1500	30	35
1600	30	35
1700	30	35
1800	30	35
2000	30	35
2100	30	35
2200	30	35
2300	30	35
2400	30	35

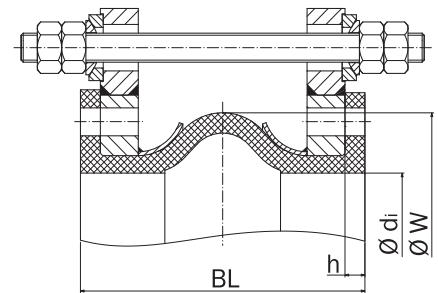

Type C-31

Lateral expansion joint, external restraints

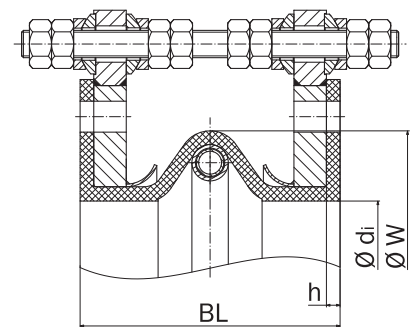

Type C-31

Lateral expansion joint, external and internal restraints, with vacuum supporting ring

CUSTOMIZED PRODUCTION

RUBBER EXPANSION JOINT TYPE C-35

LATERAL EXPANSION JOINT DN 300 – DN 3600



STRUCTURE TYPE C-35 / RUBBER BELLOWS PN 4, 10

- Lateral expansion joint consisting of a rubber bellows and press-on retaining flanges
- Restrainer segments for fitting on the mating flanges on site
- Tie rods (external restraints) to absorb reaction force from internal pressure
- Alternative: Tie rods (external and internal restraints) to absorb reaction force from internal pressure or vacuum
- Available in various bellows geometries and special lengths
- Elastic robust bellows in various rubber grades
- Synthetic fibre reinforcement
- Full-faced self-sealing rubber flanges with drilling for through bolts
- Electrical impedance 10^3 to 10^6 Ohm (DIN IEC 93, VDE 0303-30)

Rubber grade*	EPDM	NBR	CIIR
Colour code	orange	red	white
Possible uses	Cooling, sea, brackish water, acids, lyes	hydrocarbon containing liquids	Drinking water

*Check or inquire about the resistance of the rubber grade to temperature and medium.

Technical design		
DN	DN 300 – 3600	DN 300 – 1000
Pressure rate	PN 4	PN 10
Max. perm. operating pressure	4 bar*	10 bar*
Max. perm. temperature	+100 °C	+100 °C
Bursting pressure	≥ 15 bar	≥ 30 bar
Vacuum operation	with vacuum supporting ring (at permanent vacuum)	

Max. operating pressure to be set 30 % lower for shock loads.

*Please consider a decrease of pressure due to temperature (see technical annex).

FLANGES / VERSIONS

- Press-on retaining flanges with stabilizing collar
- Segments to carry the tie rods to fit on mating flanges
- Flange drilling for through bolts

	Standard	Others
Dimensions	EN 1092	ANSI, BS etc. Connection dimensions see technical annex page 213 – 215
Materials	1.0038 (S235JR), 1.0577 (S355J2)	stainless steel etc.
Corrosion protection	hot-dip galvanized	special varnish and coating, etc.

NOTE

Please comply with the general technical instructions regarding reaction force, moving force, fixed point load, installation instructions etc.

Subject to technical alterations and deviations resulting from the manufacturing process.

APPLICATIONS

- for compensating lateral movement
- for reducing thermal and mechanical tension in pipes and their system components, e.g.
 - pumps
 - condensers
- to compensate for installation inaccuracies
- to compensate for ground and foundation settlement
- as installation and dismantling aid
- power station technology
- process plant engineering

TIE ROD RESTRAINTS

- Tie rods carried on spherical washers and conical seats

Materials

Standard: tie rods 8.8

Others: stainless steel

Corrosion protection

Standard: hot-dip galvanized

Others: special coating, etc.

CERTIFICATES

- CE (PED 2014/68/EU)
- Drinking water
- TÜV Süd (KTA)

ACCESSORIES

- Vacuum supporting ring
- Internal guide sleeve
- Protective tube

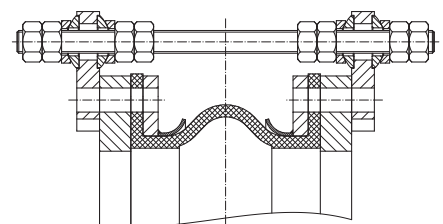

Type C-35

Lateral expansion joint, outside and inside with segments and tie rods. Dimensions and movement compensation on request

CUSTOMIZED PRODUCTION

RUBBER EXPANSION JOINT TYPE C-41

ANGULAR-EXPANSION JOINT DN 300 - DN 3600

STRUCTURE TYPE C-41 / RUBBER BELLOWS PN 4, 10

- Angular expansion joint consisting of a rubber bellows and press-on retaining flanges
- Welded hinge restraints to absorb reaction force from internal pressure or vacuum
- Various bellows geometries
- Elastic, robust bellows in various rubber grades
- Synthetic fibre reinforcement
- Full-faced, self-sealing rubber flanges with drilling for through bolts
- Electrical impedance 10^3 bis 10^6 Ohm (DIN IEC 93, VDE 0303-30)

Rubber grade*	EPDM	NBR	CIIR
Colour code	orange	red	white
Possible uses	Cooling, sea, brackish water, acids, lyes	hydrocarbon containing liquids	Drinking water

*Check or inquire about the resistance of the rubber grade to temperature and medium.

Technical design		
DN	DN 300 – 3600	DN 300 – 2800
Pressure rate	PN 4	PN 10
Max. perm. operating pressure	4 bar*	10 bar*
Max. perm. temperature	+100 °C	+100 °C
Bursting pressure	≥ 15 bar	≥ 30 bar
Vacuum operation	with vacuum supporting ring (at permanent vacuum)	

Max. operating pressure to be set 30 % lower for shock loads.

*Please consider a decrease of pressure due to temperature (see technical annex).

FLANGES / VERSIONS

- Oval press-on retaining flanges with stabilizing collar and hinge restraints
- Flange drilling for through bolts

	Standard	Others
Dimensions	EN 1092	ANSI, BS etc. Connection dimensions see technical annex page 213 – 215
Materials	1.0038 (S235JR), 1.0577 (S355J2)	stainless steel etc.
Corrosion protection	anti-corrosion primed	hot-dip galvanized, special varnish and coating, etc.

NOTE

Please comply with the general technical instructions regarding reaction force, moving force, fixed point load, installation instructions etc.

Subject to technical alterations and deviations resulting from the manufacturing process.

APPLICATIONS

- for compensating angular movement
- as double or triple joint compensation system for large movements
- restraints to absorb reaction forces
- power station technology
- process plant engineering

HINGE RESTRAINTS

- Pivot of joint bars at center of bellows
- Hinge restraints control bellows movement

Materials

Standard: 1.0038 (S235JR), 1.0577 (S355J2)

Others: stainless steel, etc.

Corrosion protection

Standard: hot-dip galvanized

Others: special varnish, special coating, etc.

CERTIFICATES

- CE (PED 2014/68/EU)
- Drinking water
- TÜV Süd (KTA)

ACCESSORIES

- Vacuum supporting ring
- Internal guide sleeve

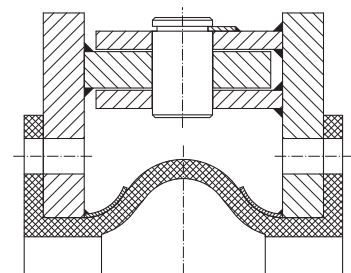

Type C-41

Angular expansion joint Dimensions and movement compensation on request

www.stenflex.com / info@stenflex.com

CUSTOMIZED PRODUCTION

RUBBER EXPANSION JOINT

TYPE D-11, D-30

ROUND UNIVERSAL EXPANSION JOINT

DN 300 – DN 7500

**STRUCTURE TYPE D-11, D-30 / RUBBER BELLOWS PN 0,7**

- **Type D-11:**
 - Round universal expansion joint consisting of a rubber bellows and rotatable flanges
 - Wide rubber rim
- **Type D-30:**
 - Round universal expansion joint consisting of a rubber bellows with stainless steel tightening straps
 - Narrow rubber rim
- Extruded endless vulcanized profile band
- Without reinforcement
- Self-sealing rubber rim

Rubber grade*	EPDM	NBR
Colour code	orange	red
Possible uses	Air, gases containing acids or lyes, dust	gases with hydrocarbon containing liquids

*Check or inquire about the resistance of the rubber grade to temperature and medium.

Technical design	
Max. perm. operating pressure	depending on DN not exceeding 0.7 bar g (see table)
Max. perm. temperature	+90 °C
Vacuum operation	for light vacuum down to 0.98 bar abs.

Max. operating pressure to be set 30 % lower for shock loads.

FLANGES / VERSIONS

- Rotable flanges
- Flange drilling for through bolts

	Standard	Others
Dimensions	DIN 86044 PN 6 nach EN 1092	Connection dimensions see technical annex page 213 – 215
Materials	1.0038 (S235JR)	1.0577 (S355J2), 1.4541, 1.4571 etc.
Corrosion protection	hot-dip galvanized	special varnish and coating, etc. Supply only for large order volumes.

NOTE

Please comply with the general technical instructions and installation instructions.

Subject to technical alterations and deviations resulting from the manufacturing process.

Admissible operating pressure, effective cross sectional area, reaction forces, moving forces and spring rates depend on expansion joint's size. Please inquire.

APPLICATIONS

- for reducing thermal and mechanical tension, e.g. at
 - ventilating fans
 - blowers
- for muffling vibration and noise
- for compensating axial and lateral movement
- to compensate for installation inaccuracies
- air and ventilation technology
- dedusting and filter engineering (clean-room technology)

ACCESSORIES

- Internal guide sleeve

DIMENSIONS STANDARD PROGRAM

DN	BL	Pressure rate bar	Ø di Bellows inner Ø	Ø W Convolution Ø unpressurized	Ø C Raised face Ø		h Rubber rim thickness		Ø D Flange outer Ø		b Flange thickness
					Type D-11	Type D-30	Type E D-11	Type D-30	DIN 86044*	EN 1092. PN 6	
					mm	mm	mm	mm	mm	mm	
300	150	0.70	300	354	370	340	12	15	440	440	10
350	150	0.60	350	404	420	390	12	15	490	490	10
400	150	0.50	400	454	470	440	12	15	540	540	10
450	150	0.45	450	504	520	490	12	15	595	595	10
500	150	0.40	500	554	570	540	12	15	645	645	10
550	150	0.37	550	604	620	590	12	15	705		10
600	150	0.33	600	654	670	640	12	15	754	755	10
700	150	0.28	700	754	770	740	12	15	856	860	10
800	150	0.25	800	854	870	840	12	15	958	975	10
900	150	0.22	900	954	970	940	12	15	1060	1075	10
1000	150	0.20	1000	1054	1070	1040	12	15	1162	1175	10
1100	150	0.18	1100	1154	1170	1140	12	15	1266		10
1200	150	0.17	1200	1254	1270	1240	12	15	1366	1405	10
1300	150	0.15	1300	1354	1370	1340	12	15	1466		10
1400	150	0.14	1400	1454	1470	1440	12	15	1566	1630	10
1500	150	0.13	1500	1554	1570	1540	12	15	1666		10
1600	150	0.12	1600	1654	1670	1640	12	15	1766	1830	10
1700	150	0.11	1700	1754	1770	1740	12	15	1866		10
1800	150	0.10	1800	1854	1870	1840	12	15	1966	2045	10
1900	150	0.10	1900	1954	1970	1940	12	15	2066		10
2000	150	0.10	2000	2054	2070	2040	12	15	2166	2265	10

Other sizes up to DN 7500 on request.

MOVEMENT COMPENSATION

DN	Δ ax Axial movement		C ax Spring rate axial		Δ lat Lateral movement ±mm	C lat Spring rate lateral N/mm	A* Effective bellows cross sectional area cm ²
	Compression -mm	Elongation +mm	Compression N/mm	Elongation N/mm			
300	25	15	12	45	20	15	750
350	25	15	14	52	20	18	1012
400	25	15	15	60	20	20	1300
450	25	15	17	67	20	22	1655
500	25	15	20	75	20	25	2000
550	25	15	22	83	20	28	2400
600	25	15	24	90	20	30	2900
700	25	15	27	105	20	35	3900
800	25	15	31	120	20	40	5100
900	25	15	35	135	20	45	6400
1000	25	15	39	150	20	51	7900
1100	25	15	43	165	20	57	9600
1200	25	15	47	180	20	63	11500
1300	25	15	51	195	20	70	13400
1400	25	15	55	210	20	77	15500
1500	25	15	59	225	20	85	17800
1600	25	15	63	240	20	93	20300
1700	25	15	67	255	20	102	22800
1800	25	15	71	270	20	112	25700
1900	25	15	75	285	20	123	28600
2000	25	15	79	300	20	135	31700

Please inquire for simultaneous (different) movement.
*Effective bellows cross sectional area is a theoretical value.

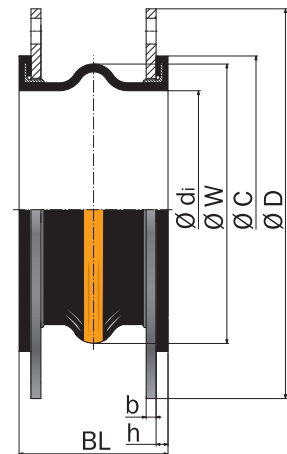

Type D-11
with flanges

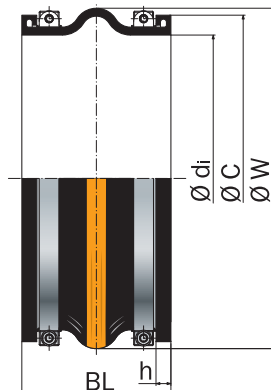

Type D-30
with tightening straps

CUSTOMIZED PRODUCTION

RUBBER EXPANSION JOINT TYPE D-21, D-22, D-41, D-42

SQUARE OR OVAL UNIVERSAL EXPANSION JOINT DN 150 – DN 7500



STRUCTURE TYPE D / RUBBER BELLOWS PN 0,7

- **Type D-21:**
 - Rectangular universal expansion joint consisting of a rubber bellows and press-on retaining frame
 - Wide rubber rim
- **Type D-22:**
 - Rectangular universal expansion joint consisting of a rubber bellows and press-on retaining frame
 - Frame with stiffening ring
 - Narrow rubber rim
- **Type D-41:**
 - Rectangular universal expansion joint consisting of a rubber bellows and press-on retaining frame (round corners)
 - Wide rubber rim
- **Type D-42:**
 - Rectangular universal expansion joint consisting of a rubber bellows and press-on retaining frame (round corners)
 - Frame with stiffening ring
 - Narrow rubber rim
- **RUBBER BELLOWS PN 0,7 bar g:**
 - Extruded, endless vulcanized profile band
 - Without reinforcement
 - Self-sealing rubber rim

Rubber grade*	EPDM	NBR
Colour code	orange	red
Possible uses	Air, gases containing acids or lyes, dust	gases with hydrocarbon containing liquids

*Check or inquire about the resistance of the rubber grade to temperature and medium.

Technical design	
Max. perm. operating pressure	depending on DN not exceeding 0.7 bar g (see table)
Max. perm. temperature	+90 °C
Vacuum operation	for light vacuum down to 0.98 bar abs.

Max. operating pressure to be set 30 % lower for shock loads.

FLANGES / VERSIONS

- Retaining frame with drilling for through bolts

	Standard	Others
Dimensions	Dimensions and drillings according to customer's specification	
Materials	1.0038 (S235JR)	unalloyed steel, stainless steel etc.
Corrosion protection	hot-dip galvanized	special varnish and coating, etc.

NOTE

Please comply with the general technical instructions and installation instructions.

Subject to technical alterations and deviations resulting from the manufacturing process.

Admissible operating pressure, effective cross sectional area, reaction forces, moving forces and spring rates depend on expansion joint's size. Please inquire.

APPLICATIONS

- for reducing thermal and mechanical tension, e.g. at
 - ventilating fans
 - blowers
- for muffling vibration and noise
- for compensating axial and lateral movement
- to compensate for installation inaccuracies
- air and ventilation technology
- dedusting and filter engineering (clean-room technology)

ACCESSORIES

- Internal guide sleeve

DIMENSIONS STANDARD PROGRAM

TYPE	DN ₁ Maximum size mm	DN ₂ Minimum size mm	BL mm	Minimum circum- ferential size inside mm	a External height of con- volution mm	C Rubber rim height mm	h Rubber rim thick- ness mm	b Flange thick- ness mm
D 21	7500	150	150	900	27	35	12	10
D 22	7500	150	150	900	27	20	15	10
D 41	7500	150	150	900	27	35	12	10
D 42	7500	150	150	900	27	20	15	10

MOVEMENT COMPENSATION / VERSIONS

TYPE	Δ ax Axial movement		Δ lat Lateral movement \pm mm
	Compression -mm	Elongation +mm	
D 21	25	15	20
D 22	25	15	20
D 41	25	15	20
D 42	25	15	20

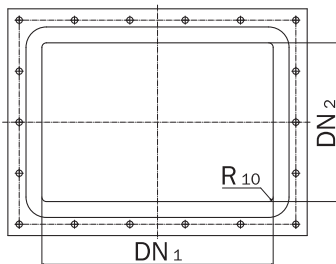
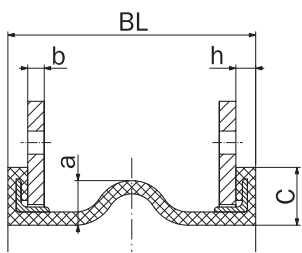

Type D-21

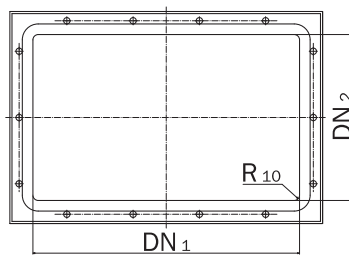
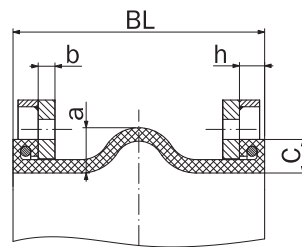

Type D-22

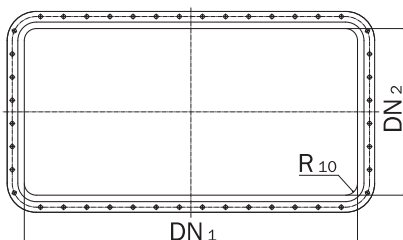
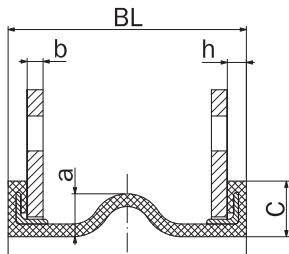

Type D-41

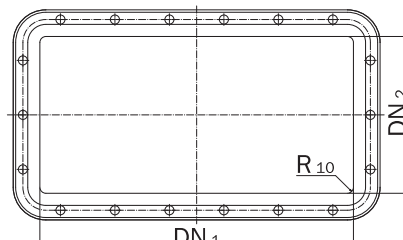
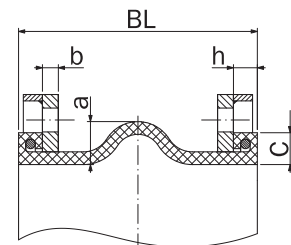

Type D-42

RUBBER EXPANSION JOINT TYPE W-1, W-2

WALL-SEALING EXPANSION JOINT DN 80 – DN 3400



STRUCTURE TYPE W-1, W-2 / RUBBER BELLOWS PN 2,5

- **Type W-1:** Wall-sealing expansion joint consisting of a flat-convoluted rubber bellows with press-on retaining flanges
- **Type W-2:** Wall-sealing expansion joint consisting of a deep-convoluted rubber bellows with press-on retaining flanges. Suitable for large movements.
- Elastic robust bellows in various rubber grades
- Synthetic fibre reinforcement
- Bellows with flat convolution (type W-1) or deep convolution (type W-2)
- Full-faced self-sealing rubber flanges with drilling for through bolts
- Electrical impedance 10^3 to 10^6 Ohm (DIN IEC 93, VDE 0303-30)

Rubber grade*	EPDM	NBR
Colour code	orange	red
Possible uses	Cooling, sea, brackish water, acids, lyes	hydrocarbon containing liquids

*Check or inquire about the resistance of the rubber grade to temperature and medium.

Technical design	
Pressure rate	PN 2,5
Max. perm. operating pressure	2,5 bar*
Max. perm. temperature	+90 °C
Bursting pressure	≥ 10 bar
Vacuum operation	with vacuum supporting ring (type W-1 only)

Max. operating pressure to be set 30 % lower for shock loads.

*Please consider a decrease of pressure due to temperature (see technical annex).

FLANGES / VERSIONS

- Press-on retaining flanges
- Flange drilling for through bolts

	Standard	Others
Materials	1.0038 (S235JR)	stainless steel etc.
Corrosion protection	hot-dip galvanized	special varnish and coating, etc.

NOTE

Please comply with the general technical instructions regarding reaction force, moving force, fixed point load, installation instructions etc.

Subject to technical alterations and deviations resulting from the manufacturing process.

APPLICATIONS

- to seal ducts on
 - vessels, or containers
 - wall ducts
- for compensating axial and lateral movement between pipe and wall duct
- for reliable sealing against ground-water
- process plant engineering
- power station technology
- cement industry

CERTIFICATES

- CE (PED 2014/68/EU)

ACCESSORIES

- Vacuum supporting ring (type W-1)

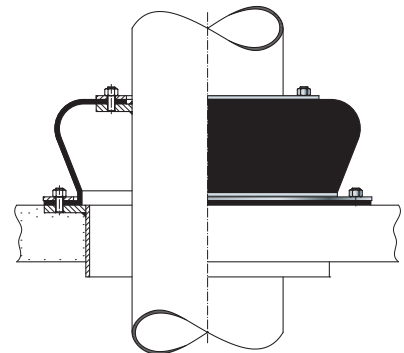

Installation drawing type W-1

DIMENSIONS STANDARD PROGRAM TYPE W-1 / BL 150

DN Pipe- line	DN Wall duct	Pres- sure rate bar	Bellows		Wall duct			Pipeline				Δ ax Axial move- ment \pm mm	Δ lat Lateral move- ment \pm mm	Weight approx. kg
			\varnothing D Bellows inner \varnothing mm	h Rubber flange thick- ness mm	\varnothing d _a Flange outer \varnothing mm	\varnothing K ₁ PCD \varnothing mm	n ₁ x \varnothing d ₁ Drilling mm	\varnothing d _i Flange inner \varnothing mm	\varnothing K ₂ PCD \varnothing mm	n ₂ x \varnothing d ₂ Drilling mm	b Flange thick- ness mm			
80	250	2.5	290	8	430	380	8x14	120	160	8x14	10	20	30	10.0
100	250	2.5	290	8	430	380	8x14	140	190	8x14	10	20	30	11.5
150	300	2.5	440	12	640	560	12x23	185	265	8x23	10	20	30	23.5
200	400	2.5	495	12	695	615	12x23	240	320	12x23	10	20	30	26.5
250	450	2.5	570	12	770	690	12x23	315	395	12x23	10	20	30	29.5
250	500	2.5	570	12	770	690	12x23	285	365	12x23	10	20	30	29.5
300	500	2.5	570	12	770	690	12x23	350	430	12x23	10	20	30	31.5
400	600	2.5	665	12	865	785	16x23	430	510	16x23	10	20	30	36.5
500	700	2.5	770	12	970	890	16x23	535	615	16x23	10	20	30	43.0
600	800	2.5	870	12	1070	990	16x23	635	715	16x23	10	20	30	48.5
700	900	2.5	975	12	1175	1095	24x23	730	810	24x23	15	20	30	64.5
800	1000	2.5	1050	12	1280	1200	24x23	840	920	24x23	15	20	30	73.5
900	1100	2.5	1180	12	1380	1300	24x23	940	1020	24x23	15	20	30	73.5
1000	1200	2.5	1280	12	1480	1400	24x23	1040	1120	24x23	15	20	30	95.0
1100	1300	2.5	1380	12	1580	1500	24x23	1140	1220	24x23	15	20	30	105.0
1200	1400	2.5	1490	12	1690	1610	24x23	1250	1330	24x23	15	20	30	114.5
1400	1600	2.5	1636	12	1880	1800	24x23	1440	1520	24x23	15	20	30	161.5
1600	1800	2.5	1880	15	2080	2000	28x23	1640	1720	28x23	15	20	30	148.5
1800	2000	2.5	2080	15	2280	2200	32x23	1840	1920	32x23	15	20	30	165.0
2000	2200	2.5	2280	15	2480	2400	36x23	2060	2140	36x23	15	20	30	179.0
2200	2400	2.5	2480	15	2680	2600	36x23	2260	2340	36x23	15	20	30	196.0
2400	2600	2.5	2665	15	2880	2780	48x23	2460	2540	48x23	15	20	30	210.0
2500	2700	2.5	2785	15	2980	2900	48x23	2560	2640	36x23	15	20	30	220.0
3000	3200	2.5	3280	15	3490	3410	48x23	3050	3130	48x23	15	20	30	270.0
3400	3600	2.5	3610	20	3830	3750	108x23	3450	3530	108x23	15	20	30	330.0

DIMENSIONS STANDARD PROGRAM TYPE W-1 / BL 280

2200	2400	2.5	2480	15	2680	2600	36x23	2260	2340	36x23	15	40	60	226.0
------	------	-----	------	----	------	------	-------	------	------	-------	----	----	----	-------

DIMENSIONS STANDARD PROGRAM TYPE W-2

DN Pipe- line	DN Wall duct	Pres- sure rate bar	Bellows		Wall duct			Pipeline				Δ ax Axial move- ment \pm mm	Δ lat Lateral move- ment \pm mm	Weight approx. kg
			\varnothing D Bellows inner \varnothing mm	h Rubber flange thick- ness mm	\varnothing d _a Flange outer \varnothing mm	\varnothing K ₁ PCD \varnothing mm	n ₁ x \varnothing d ₁ Drilling mm	\varnothing d _i Flange inner \varnothing mm	\varnothing K ₂ PCD \varnothing mm	n ₂ x \varnothing d ₂ Drilling mm	b Flange thick- ness mm			
200	450	2.5	610	10	740	680	12x23	240	290	12x18	10	80	80	19.5
400	800	2.5	890	12	1025	965	16x23	490	550	16x23	10	80	80	34.0
500	900	2.5	1020	12	1175	1115	24x23	620	680	24x23	12	80	80	48.0
800	1300	2.5	1260	15	1480	1420	24x23	850	910	24x23	15	80	90	93.0

VERSIONS

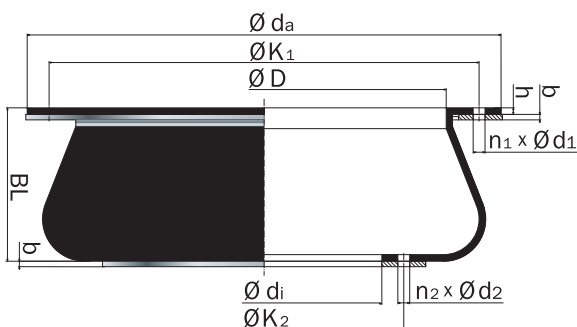

Type W-1

Wall-sealing expansion joint, flat-convoluted

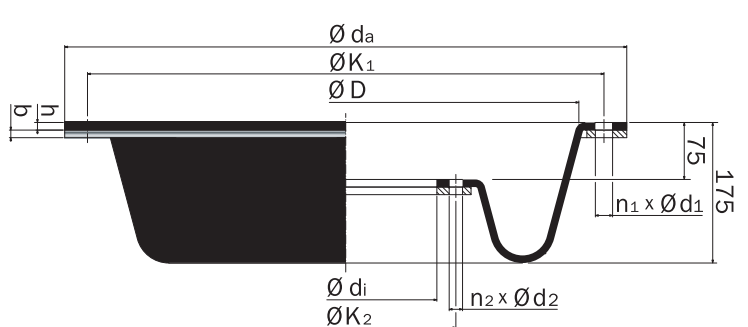

Type W-2

Wall-sealing expansion joint, deep-convoluted, for large movements

PIPE CONNECTORS PROGRAMME OVERVIEW

STENFLEX® **PIPE CONNECTORS** ARE INSTALLED ON PUMPS,
CONTROL FITTINGS, MACHINERY AND INDUSTRIAL EQUIPMENT
SPECIFICALLY TO INTERCEPT UNDESIRABLE SOUND TRANSMISSION
AND ABSORB VIBRATION OCCURING IN PIPELINES.



QUALITY.

PIPE CONNECTORS

GENERAL DESCRIPTION OF PIPE CONNECTORS

STENFLEX® pipe connectors, just like STENFLEX® rubber expansion joints, have been used for 50 years as the preferred connection elements in appliance and piping engineering.

Pipe connectors are produced from top quality materials in large-scale industrial manufacturing. This guarantees a uniform high standard of quality and a long service life for our products.

STENFLEX® pipe connectors undergo constant quality monitoring to EN ISO 9001:2015 and come with type approval and suitability test certificates based on DIN 4809.

PURPOSE

Pipe connectors are used at appliances, engines, machines, pumps and compressors primarily for

- absorbing sound and vibration/ oscillation transmission
- in many different industries, such as
- Mechanical engineering
 - Shipbuilding
 - Domestic industry
 - Heating systems
 - Water supply/treatment systems

STRUCTURE

The STENFLEX® rubber-metal pipe connector has been optimized by calculation and experimentation to produce a well absorbing, pressure-resistant connecting element. This pipe connector consists of a cylindrical elastomer body with smooth inner surfaces and a fully embedded steel flange.

Absolute metallic separation of the steel flanges results in excellent noise or vibration damping by the elastomer body in-between. The pipe connectors have an integrated rubber sealing strip in the sealing area so that no additional gaskets are necessary (self-sealing).

CONNECTION PARTS / FLANGES

The embedded steel flanges of the rubber-metal pipe connectors have threaded holes.

Connection dimensions as per DIN 2501, PN 6 or PN 10.

During installation, the screw lengths prescribed in the data sheets must be observed.



Rubber-metal pipe connector

Structure: Rubber body with fully embedded steel flanges

Damping, movement compensation:

Rubber-metal pipe connectors dampen noise and vibration caused by appliances, motors or pumps. Movement cannot be absorbed by these rubber-metal pipe connectors.

Fixed points:

Robust pipe fixed points and correct pipeline routing are necessary to absorb the axial forces.

Rubber grade	CR Polychloroprene
Trade name	Neoprene Baypren
Properties	Rubber grade with good oil, weather and flame resistance, very good ageing resistance. Resistant to various inorganic chemicals. Impermeable to gas for hydrocarbons. Temperature resistance in continuous operation* -30 °C to +100 °C.
Applications	Water, hot water, cooling water

* The given temperature for continuous operation refers solely to the rubber grade. When reinforcements or other filling material are embedded, the temperature resistance in continuous operation increases.

DEVELOPMENT / DESIGN

STENFLEX[®] pipe connectors are rated with state-of-the-art development tools (CAD, FEM), designed and optimized by experimentation already during the development phase.

As a result, they have outstanding absorbing properties. Standardized flange connections facilitate installation and safe integration in a pipe system.

VERSIONS

Pipe connectors are supplied ready for installation.

APPLICATIONS / POSSIBLE USES / INDUSTRIES

Basic pipe connector types		Steel pipe connectors
STENFLEX [®] Pipe connector types		GRV
Applications	Reducing tension	
	Absorbing vibration	■
	Muffling noise	■
Possible uses	Pipelines	■
	Engines	
	Pumps	■
	Fittings	■
Industries	Domestic industry	■
	Heating installations	■

Table showing the prime applications, possible uses and industries

PROGRAM SUMMARY

	Type	DN	Pressure rate bar	Max. operating temperature	Material	Connection parts/restraint elements	Page
	GRV	DN 20 - 200 DN 20 - 200	PN 6 PN 10	+100 °C +100 °C	CR CR	flange with female thread	90

RUBBER-METAL PIPE CONNECTOR TYPE GRV

VIBRATION AND NOISE DAMPER DN 20 – DN 200



STRUCTURE TYPE GRV / RUBBER BODY PN 6, PN 10

- Rubber-metal pipe connector consisting of a cylindrical rubber body with fully embedded steel flanges
- Steel flanges with threaded holes
- Absolute metallic separation of the steel flanges
- From DN 50 elastic embedded spacing control bolts
- Cylindrical rubber body made of elastic synthetic rubber
- Smooth rubber core therefore no contact between medium and flange
- Self-sealing rubber raised face
- Electrical impedance 10^3 bis 10^6 Ohm (DIN IEC 93, VDE 0303-30)

Rubber grade*	CR
Possible uses	Hot water, cold water, acids, lyes

*Check or inquire about the resistance of the rubber grade to temperature and medium.

Technical design		
DN	DN 20 – 200	
Pressure rate	PN 6	PN 10
Max. perm. operating pressure	6 bar	10 bar
Max. perm. Temperature	-30 °C bis +100 °C / to +110 °C for brief periods*	
Bursting pressure	≥ 48 bar	
Vacuum operation	≥ 0,05 bar abs.	

* For temps. exceeding +100 °C, the manufacturer's approval must be obtained for the corresponding operating conditions..

FLANGES / SCREW LENGTHS

Do not choose the screws to be too long; overlong screws damage the rubber body.

Please note the recommended screw length L and L₁ (see table).

Detailed installation instructions indicating the necessary torques are included with every pipe connector.

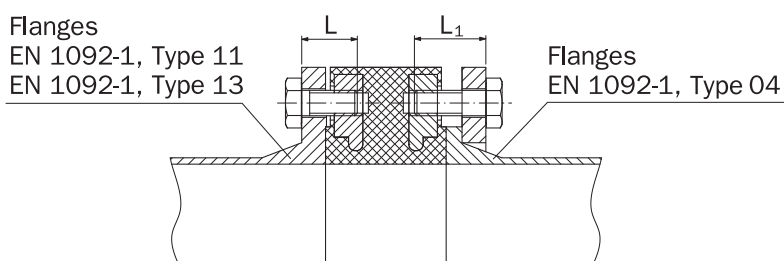

NOTE

Do not use to absorb tensile force, expansion, tension; depending on temperature, STENFLEX® expansion joints made of rubber or steel should be used for this purpose.

Elastic elements in pipelines separate the rigid system and release the reaction force, produced by pipeline inner pressure. For the rubber-metal pipe connectors to work safely and reliably, it is presumed that the pipes are routed properly and the fixed points (HFP) are adequately rated to the reaction force.

Chemicals used for water treatment (particularly in heating systems and coolant systems) can corrode the materials of pipe connector. According to VDI Directive 2035, DIN 4809 part 1 and VGB R 455P, the manufacturer of the chemicals must state that the materials used in the pipe connector will not be damaged by the chemicals.

Please comply with the general technical instructions. Subject to technical alterations and deviations resulting from the manufacturing process.

APPLICATIONS

- for interrupting unwanted sound and noise transmission
 - in pipeline systems
 - in heating systems
 - at pumps
 - at control fittings
 - at machines
 - at fittings and appliances
- in domestic industry
 - in residential properties
 - in hospitals
 - in schools
 - in public buildings
- in industrial applications

CERTIFICATES

- Suitability approval for warm water and heating systems

DIMENSIONS STANDARD PROGRAM PN 6

DN	BL*	Ø d _i Inner Ø mm	Ø C Raised face Ø mm	Ø D Outer Ø mm	G Thread Ø mm	L Threaded length mm	PN Flange- connection EN 1092	Screws DIN 933		Washer DIN 125	Weight approx. kg
								Thread	L mm		
20	76	23	50	94	4 x M 10	14	6	M 10	25	10,5	1.4
25	76	29	60	104	4 x M 10	16	6	M 10	25	10,5	1.9
32	76	38	70	124	4 x M 12	16	6	M 12	30	13,0	2.5
40	76	44	80	134	4 x M 12	16	6	M 12	30	13,0	3.1
50	76	55	88	144	4 x M 12	16	6	M 12	30	13,0	3.3
65	76	71	108	164	4 x M 12	16	6	M 12	30	13,0	4.0
80	76	81	128	194	4 x M 16	18	6	M 16	35	17,0	6.3
100	76	108	148	214	4 x M 16	18	6	M 16	35	17,0	6.6
125	76	133	178	244	8 x M 16	18	6	M 16	35	17,0	8.2
150	76	160	202	270	8 x M 16	18	6	M 16	35	17,0	8.9
200	96	209	258	325	8 x M 16	20	6	M 16	40	17,0	13.9

*The measure BL (length) is approx. 6 mm shorter when fitted.

DIMENSIONS STANDARD PROGRAM PN 10

DN	BL*	Ø d _i Inner Ø mm	Ø C Raised face Ø mm	Ø D Outer Ø mm	G Thread Ø mm	L Threaded length mm	PN Flange- connection EN 1092	Screws DIN 933			Washer DIN 125	Weight approx. kg
								Thread	L mm	L ₁ mm		
20	76	23	60	109	4 x M 12	14	10	M 12	30	40	13	2.1
25	76	29	70	119	4 x M 12	16	10	M 12	30	45	13	2.7
32	76	38	80	144	4 x M 16	16	10	M 16	35	45	17	3.9
40	76	44	90	154	4 x M 16	16	10	M 16	35	45	17	4.4
50	76	55	100	169	4 x M 16	16	10	M 16	35	50	17	5.0
65	76	71	115	189	4 x M 16	16	10	M 16	35	50	17	6.0
80	76	81	130	204	8 x M 16	18	10	M 16	40	55	17	7.1
100	76	108	158	224	8 x M 16	18	10	M 16	40	55	17	7.6
125	76	133	180	255	8 x M 16	18	10	M 16	40	55	17	9.5
150	76	160	210	291	8 x M 20	18	10	M 20	45	60	21	11.6
200	96	209	265	345	8 x M 20	20	10	M 20	45	65	21	17.7

*The measure BL (length) is approx. 6 mm shorter when fitted.

VERSIONS

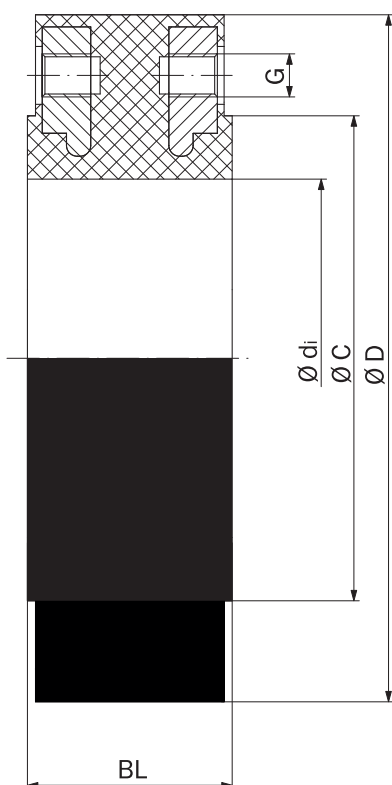

Type GRV

Rubber-metal pipe connector
with elastic embedded spacing
control bolt

STEEL EXPANSION JOINTS

PROGRAMME OVERVIEW

STENFLEX® **STEEL-EXPANSION JOINTS** ARE USED AS FLEXIBLE PIPE CONNECTIONS IN MECHANICAL ENGINEERING AND THE CONSTRUCTION OF INDUSTRIAL EQUIPMENT AND PIPELINES. THEY ARE CHARACTERISED BY HIGH COMPRESSIVE STRENGTH AND THERMAL ENDURANCE, TESTED VACUUM STABILITY AND GOOD CHEMICAL RESISTANCE.

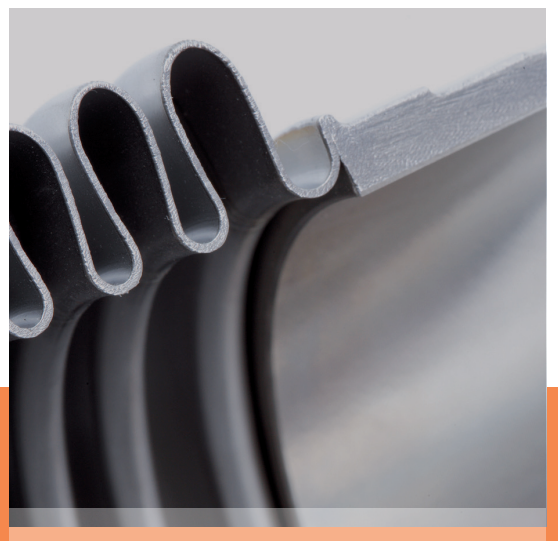
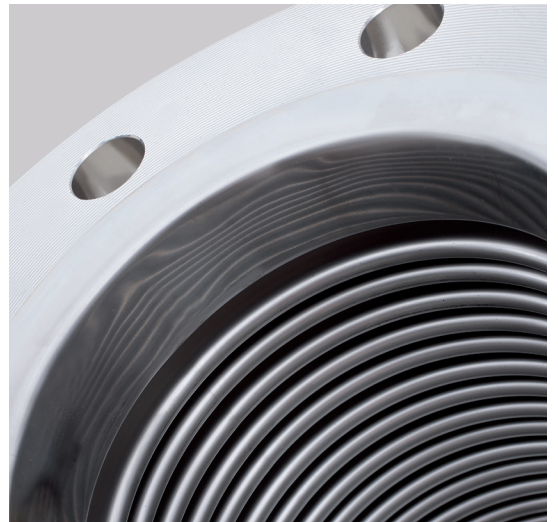

QUALITY.

STEEL EXPANSION JOINTS

GENERAL DESCRIPTION OF STEEL EXPANSION JOINTS

STENFLEX® steel expansion joints have served with distinction for 50 years. They are the preferred flexible pipe connection elements of choice in manufactured appliances, machinery, apparatus and piping engineering.

Constant further development and innovations update our product range to meet the needs of current and changing markets, and fulfil the requirements of industry in regard to:

- Operating safety
- Reliability
- Pressure and temperature resistance
- Vacuum stability
- Flexibility
- Impermeability
- Corrosion resistance
- No maintenance
- Long service life

The large-scale industrial manufacture of steel bellows, constant control of compliance with all manufacturing, business and quality processes in line with EN ISO 9001:2015 and decades of experience in the development and manufacture of steel expansion joints: all this guarantees a uniform product of the highest standard. It underlines the STENFLEX® Quality Claim.

Our expertise in expansion joint engineering is reflected in the long service life and consequently in the high operational reliability of our steel expansion joints, thanks to the excellent production functionality and quality.

For decades our steel expansion joints have been used in a wide variety of applications, and guarantee trouble-free operation on-site.

STENFLEX® has been assessed and approved as manufacturer of steel expansion joints, on the basis of AD norms of the Pressure Equipment Directive and international standards. Calculations are based among other factors, on AD 2000-B13, DIN EN 14917 and EJMA. STENFLEX® steel expansion joints have been certified by numerous classification, and acceptance societies, and bear the CE mark.

Our engineers together with our R&D department are always available for technical consultation, and ready to help in solving specific application problems at any time.

APPLICATIONS

Steel expansion joints are used in appliances, machines, apparatus and pipe systems where space is restricted

- to compensate for movement
- to compensate for expansion
- to reduce tension
- to absorb noise and oscillation transmission
- to compensate for ground and foundation settlement
- as adapters to compensate for installation inaccuracies
- as dismantling pieces for fittings

Steel expansion joints are flexible pipe connection elements and are used in a variety of industrial applications:

- Machine engineering
- Domestic industry
- Chemical industry
- Process plant engineering
- Gas and water supply
- Exhaust technology

Our expansion joints are delivered ready for installation. STENFLEX® manufactures expansion joints in nominal widths DN 15 – DN 2800 and for nominal pressure rates PN 1 - PN 25. A wide range of materials is used, with temperature resistance from -196 °C to +900 °C.

Together with the standard and basic versions featured in the catalogue, special versions can also be developed and produced on request, for special operating conditions or special structures.

Connection parts (that deviate from DIN) such as EN, ISO, ANSI, VG, SAE standards etc. are also available.

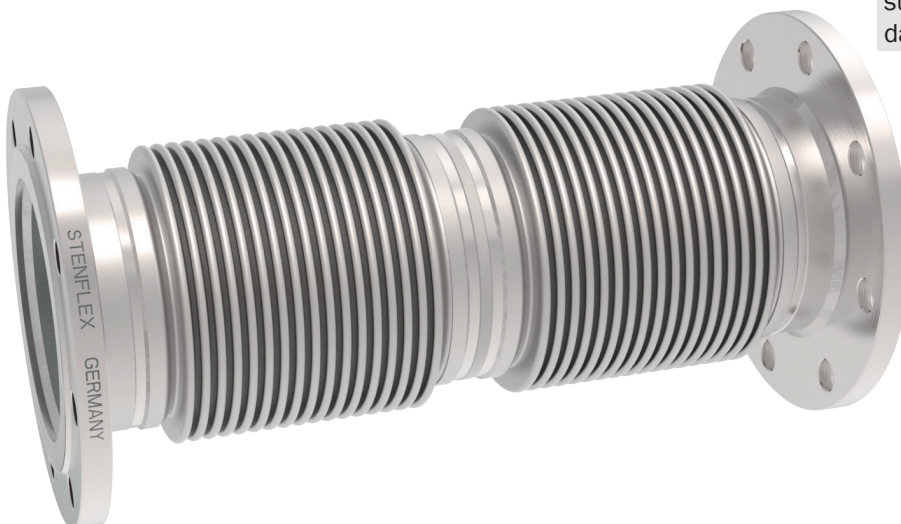

DEVELOPMENT / DESIGN

STENFLEX® steel expansion joints are rated theoretically using state-of-the-art computing techniques (which include the Finite Element Method). They are optimized under experimental conditions. National and international calculation standards are used to rate the bellows.

Our development engineers use the most up-to-date development tools throughout the development stage to validate the construction process in terms of form, function and installation.

Hence we can offer our customers the following advantages:

- Design and development in line with the specific requirements, resulting in safe and extremely durable expansion joints
- Efficient products by incorporating superior functionality
- Structures that are easy to install
- Reduced lead times for special designs

VERSIONS

STENFLEX® steel expansion joints vary according to the following criteria:

- type (universal/lateral/angular expansion joints)
- pipe connection type (flange, welding end or threaded connection)
- material quality of the bellows (rated to the media transported in the pipes)
- bellows structure (rated to the movement, pressure and temperature load)

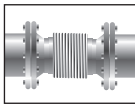
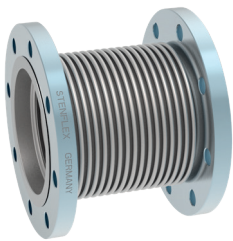

Axial expansion joints

Structure:

Steel bellows with connection parts (flange, welding end or threaded connection).

Movement absorption:

Axial shift, and slight all-round movement of the expansion joint is possible. Axial expansion joints with two bellows are used to absorb larger movement.

Fixed points:

Robust pipe fixed points and correct pipe routing are necessary to absorb the axial forces.

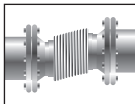
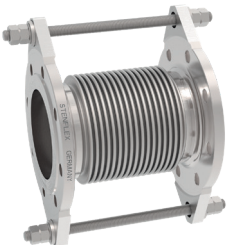

Lateral expansion joints

Structure:

Steel bellows with laterally movable restraints and flanges or welding ends.

Movement absorption:

Lateral shift of the expansion joint is possible. The restraint absorbs axial reaction force and relieves the pressure on the pipe's fixed points. Lateral expansion joints, with two bellows and a connecting pipe are used to absorb large movement.

Fixed points:

Only light fixed points are required to absorb lateral movement and friction force.

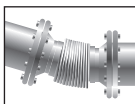
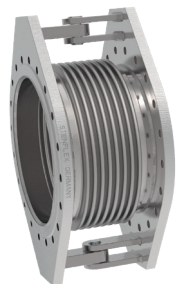

Angular expansion joints

Structure:

Steel bellows with hinge restraint and flanges or welding ends. The rotating axis of the hinge restraint is in the middle of the bellows.

Movement absorption:

Angular movement of the expansion joint is possible. The angular joints regulate a defined angular movement, absorb axial reaction force and relieve the pressure on the pipe's fixed points.

We differentiate between angular expansion joints with a hinge (bellows angular movement guided on one plane) and angular expansion joints with a cardan hinge restraint (bellows movement guided on two planes).

Fixed points: Only light fixed points are required to absorb angular movement force and friction force.

STEEL EXPANSION JOINTS

GENERAL DESCRIPTION (STEEL BELLOWS)

STRUCTURE

STENFLEX® steel bellows are available in a variety of structures and versions. The steel bellows is the flexible element of every expansion joint. It must fulfil the requirement for good movability with simultaneous pressure resistance.

Variable parameters (wall thickness, number of plies, convolution geometry, number of convolutions) determine the pressure resistance, movement absorption and spring rate (self-resisting force) of the bellows. One-ply, two-ply and multi-ply bellows are manufactured from various materials with different wall thicknesses.

Our calculation methods ascertain the stability limits. The ability to withstand buckling is the prime criterion for smaller bellows diameters, whereas in larger bellows diameters it is convolution stability.

MATERIAL QUALITIES

STENFLEX® expansion joint bellows are manufactured from top quality sheet metal. Different material qualities are used to cover the many operating conditions in various industrial applications.

The outstanding characteristic of the steels and alloys is their particular resistance to chemically aggressive liquid media. Please ask our Technical Consulting Service for detailed information about the media resistance of individual materials.

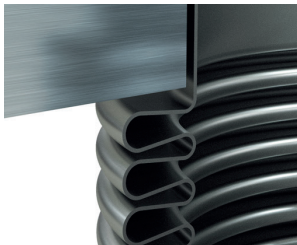

All products are marked with type, nominal size and pressure rating.

Multiple convolution bellows (e.g. two-ply) in various material qualities



The corrugations of the bellows compensate for movements by elastic deformation.

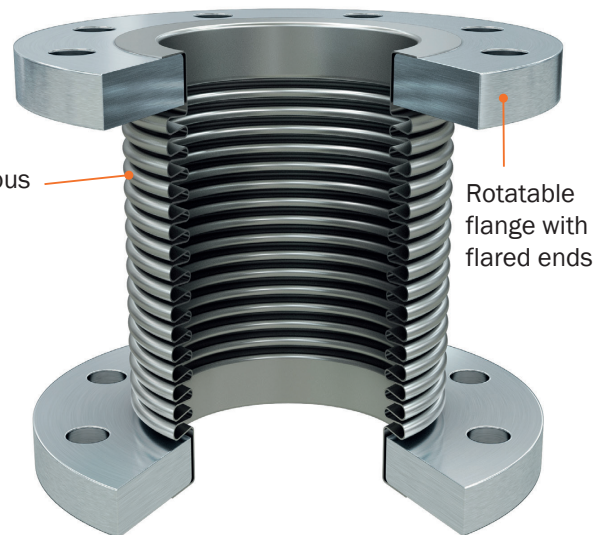

Rotatable flange with flared ends

Bellows material	Material No. as per DIN EN	Designation as per DIN EN (DIN)	Properties	Applications
Stainless steel	1.4541	X6CrNiTi18-10	For aggressive media, good endurance for low temperature	Food-product industry, film and photo industry, nitrogen fertilizer industry, silencer and exhaust purification systems, low temperature technology
	1.4404 1.4571	X2CrNiMo17-12-2 X6CrNiMo-Ti17-12-2	The Mo component results in greater resistance to pitting corrosion from media containing chloride, suitable for drinking water and food products	Chemical industry, oil, soap and textile industries, dyeing plant, dairies, breweries, pharmaceutical industry, petrochemical and coal-tar industry, water supply and water treatment
Heat resistant steel	1.4828	X15CrNiSi20-12	Heat resistant	Furnace and apparatus construction, air pre-heaters, steel and metallurgical industry
	1.4878	X12CrNiTi18-9	Heat resistant	Steel and metallurgical industry
Nickel-based alloy	2.4858 (Incoloy 825)	NiCr21Mo	Highly resistant to oxidizing and non-oxidizing hot acids (sulphuric and phosphoric acid)	Chemical engineering, plant for air purification, oil and gas extraction, reprocessing plant, acid production, petrol facilities

STEEL EXPANSION JOINTS

GENERAL DESCRIPTION (STEEL BELLOWS)

RATING, SERVICE LIFE

Steel bellows, as a rule, are rated for a temperature of +20 °C, the nominal pressure and a load of 1000 load cycles.

One load cycle refers to the procedure beginning at zero position, from where the expansion joint moves to the maximum elongation (positive) position, back through the zero position to the maximum compression (negative) position, and back to the zero position.

Together with the tolerable operating conditions

- pressure
- temperature
- movement
- number of load cycles

the following parameters can also influence the service life of expansion joints:

- corrosion
- high-frequency oscillations
- sympathetic vibration
- pressure shocks
- temperature shocks
- incorrect installation

Corrosion can be caused by incorrect selection or combination of materials, conveyance of aggressive media and inappropriate cleaning with chemical agents.

High-frequency oscillations and simultaneous vibration must be avoided by all means, because this will result in fatigue failure/fracture.

Pressure and temperature shocks must be avoided. It is important not to exceed the permitted maximum values.

Incorrect installation can be prevented by compliance with our installation and assembly instructions.

In the case of unrestrained expansion joints, the absence of fixed points can cause the pipeline to shift. This usually destroys the expansion joint.

CONNECTION PARTS

STENFLEX® steel expansion joints are supplied ready for installation. They are connected to pipes, fittings, pumps, tanks etc. by flanges, welding ends or threaded connections. The connections are standardized to fit commercially available flanges, threads and pipes.

Flange material	Material No. as per DIN EN	Designation as per DIN EN (DIN)
Unalloyed steel	1.0038	S235JR
	1.0577	S355J2
Stainless steel	1.4404	X2CrNiMo17-12-2
	1.4541	X6CrNiTi18-10
	1.4571	X6CrNiMoTi17-12-2
	1.4828	X15CrNiSi20-12
High-temperature steel	1.0425	P265GH (H II)
	1.0460	P250GH (HI)

FLANGES

STENFLEX® steel expansion joints, series SF, are supplied with rotatable flanges or fixed flanges.

Standard flanges are drilled in accordance to EN 1092-1. Standard screws can be used because the flanges are drilled for through bolts. Other flange connections are possible, e.g. to DIN EN, ANSI, BS, VG, SAE, for exhaust pipes and ventilation systems.

Flanges for lateral expansion joints are equipped with ears for tie rod restraints. The design differs between flanges with molded ears and oval flanges, depending on expansion joint type and size.

Angular expansion joints are equipped with oval flanges and welded hinge restraints.

Flanges of unalloyed steel are electro-galvanized or given an anti-corrosion prime coating. Stainless steel is used to meet tougher corrosion protection requirements. Other materials and forms of corrosion protection (hot-dip galvanizing, special varnish, special coating etc.), can be supplied on request.

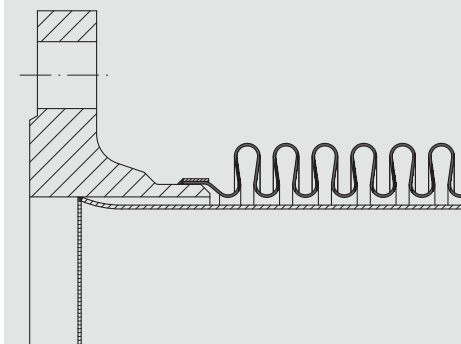

Steel expansion joint with fixed flange

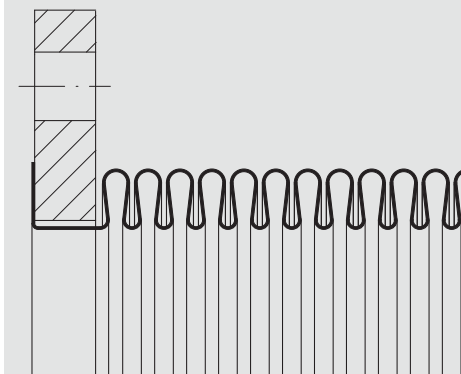

Steel expansion joint with rotatable flanges with flared bellows

Flanges, see also page 98

STEEL EXPANSION JOINTS

GENERAL DESCRIPTION OF STEEL EXPANSION JOINTS

WELDING ENDS

Steel expansion joints, series SA, are equipped with welding ends. The dimensions of the welding ends are rated in accordance with the ISO pipe standards, or to customer specifications.

Welding ends of unalloyed steel are given an anti-corrosion prime coating. Stainless steel is used to meet tougher corrosion protection requirements. Other materials, and forms of corrosion protection (special varnish, special coating etc.), are available on request.

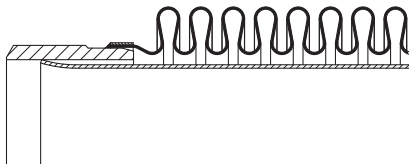

Steel expansion joint with welding ends – bellows welded to reinforcing ring and internal guide sleeve

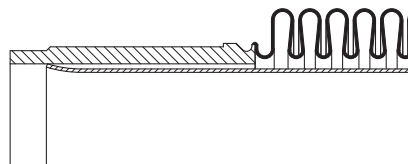

Steel expansion joint with welding ends – bellows welded with flared seam and internal guide sleeve

Welding end material	Material No. as per DIN EN	Designation as per DIN EN (DIN)
Unalloyed steel	1.0038	S235JR
	1.0577	S355J2
Stainless steel	1.4404	X2CrNiMo17-12-2
	1.4541	X6CrNiTi18-10
	1.4571	X6CrNiMoTi17-12-2
	1.4828	X15CrNiSi20-12
High-temperature steel	1.0345	P235GH
	1.5415	16Mo3 (15Mo3)

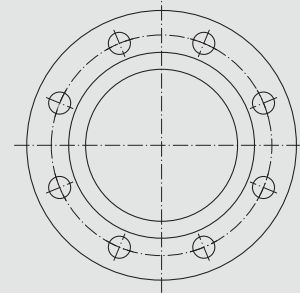

Standard flange (axial and universal expansion joints)

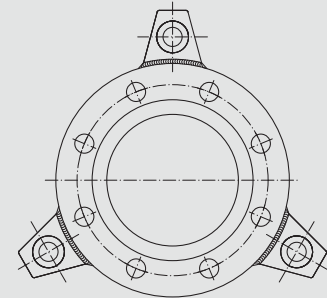

Flange with welded restraint or molded ears to accommodate the tie rods (lateral expansion joints)

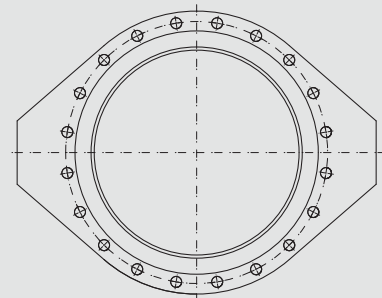

Oval flange (angular expansion joints)

Flanges, see also page 97

THREADED CONNECTIONS

STENFLEX® steel expansion joints with threaded connections series SG, are primarily used in the domestic industry for smaller dimensions up to DN 50. They are equipped with female or male thread, in accordance with ISO 7-1 (DIN 2999).

Threaded connections of high-temperature steel are given an anti-corrosion prime coating. Malleable castings are electrogalvanized. Stainless steel is used to meet tougher corrosion protection requirements. It is also suitable for copper and plastic pipes. Other materials, and forms of corrosion protection (special varnish, special coating etc.), are available on request.

Threaded part material	Material No. as per DIN EN	Designation as per DIN EN (DIN)
Malleable casting	0.8040	GJMW-400-5 (GTW-40-05)
Stainless steel	1.4541	X6CrNiTi18-10

STEEL EXPANSION JOINTS

GENERAL DESCRIPTION OF STEEL EXPANSION JOINTS

RESTRAINTS

Restraints are used for lateral and angular expansion joints. The restraints absorb axial reaction force produced by inner pressure. Even so, the connected pipe must be equipped with light fixed points to absorb moving force and moments. Precise rating details and operating parameters of the corresponding machinery or equipment must be known to correctly calculate the degree of restraint needed. Standard restraints are available for the lateral and angular expansion joint program. They are calculated on the basis of the material strength values at +20 °C. Reduced strength values at higher temperatures are taken into account.

TIE ROD RESTRAINTS

Lateral expansion joints are equipped with adapters for tie rod restraints. The design differs between flanges with welded ears or oval flanges depending on the expansion joint type and size. Tie rod restraints run flexibly on spherical washers and conical seats.

The tie rods, spherical washers, conical seats, and nuts are electrogalvanized. Ears of unalloyed steel are given an anti-corrosion prime coating. Stainless steel is used to meet tougher corrosion protection requirements. Other materials, and forms of corrosion protection (special varnish, special coating, etc.), can be supplied on request.

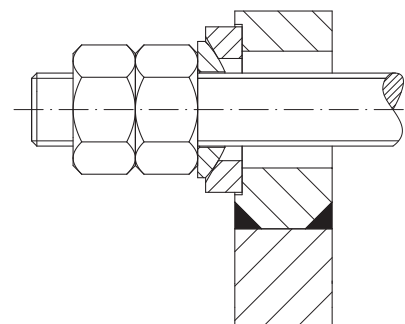

External restraint with spherical washers and conical seats (lateral expansion joints)

Material tie rod restraint	Material No. as per DIN EN	Designation as per DIN EN (DIN) or strength class
Unalloyed steel		
Ears	1.0038	S235JR
Tie rods		5.6, 8.8
Nuts		5, 8
Spherical washers/ conical seats	1.0401	C15
Stainless steel		
Ears	1.4541	X6CrNiTi18-10
	1.4571	X6CrNiMo-Ti17-12-2
Tie rods, nuts	A2	50, 70
	A4	50, 70
Spherical washers/ conical seats	1.4305	X8CrNiS18-9
High-temperature steel		
Ears	1.5415	16Mo3 (15Mo3)
Tie rods, nuts	1.7225	42CrMo4
	1.7709	21CrMoV5-7

STEEL EXPANSION JOINTS

GENERAL DESCRIPTION OF STEEL EXPANSION JOINTS

HINGE RESTRAINTS

Angular expansion joints are equipped with oval flanges and hinge restraints that consist of joint bars and bolts.

Connection parts of unalloyed steel are given an anti-corrosion prime coating. Stainless steel parts are used to meet tougher corrosion protection requirements. Other materials and forms of corrosion protection (special varnish, special coating etc.) can be supplied on request.

Material hinge restraint	Material No. as per DIN EN	Designation as per DIN EN (DIN)
Unalloyed steel	1.0038	S235JR
	1.0577	S355J2
Stainless steel	1.4541	X6CrNiTi18-10
	1.4571	X6CrNiMoTi17-12-2
High-temperature steel	1.0305	P235G1TH (St 35.8I)
	1.5415	16Mo3 (15Mo3)

ACCESSORIES

STENFLEX® steel expansion joints can be provided with the following accessories:

- Internal guide sleeve
- Guide sleeve
- Protective cover

INTERNAL GUIDE SLEEVES

Internal guide sleeves can be inserted or welded into the expansion joint. As a rule they are made of stainless steel. Internal guide sleeves are required to handle higher flow speeds (see diagram) and the resulting possible resonance in the bellows. Also to deal with turbulence as a result of deflection in the direction of flow (e.g. behind pumps, valves, T-pieces, pipe bends).

Even under these conditions, the internal guide sleeve is intended to guide the medium turbulence free through the convoluted bellows.

An internal guide sleeve also provides the bellows with reliable protection from abrasion by the medium. In this case the internal guide sleeve must have thicker walls.

Axial expansion joints are equipped with cylindrical internal guide sleeves and lateral expansion joints with conical internal guide sleeves. Axial expansion joints with internal guide sleeve and flared flange require an additional seal between the bellows flare and the flared flange. In conical internal guide sleeves the tapered cross-section must be taken into account (pressure loss and flow rates). Telescopic internal guide sleeves with a narrow gap are used where the medium is able to flow through the expansion joint in both directions. Attention must be paid to the direction of flow to ensure that expansion joints with internal guide sleeve function properly. The direction of flow is indicated by the arrow marked on the expansion joint.

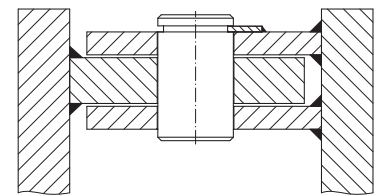

Hinge restraint with joint bars and bolts (angular expansion joints)

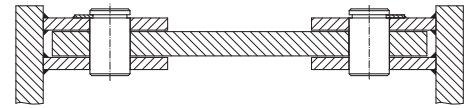

Hinge restraint with joint bars and bolts (lateral expansion joints)

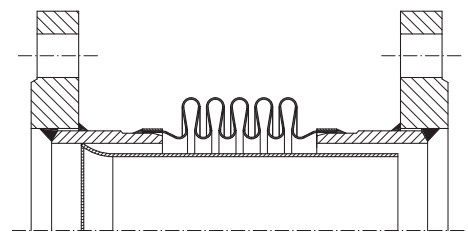

Axial expansion joint with cylindrical internal guide sleeve

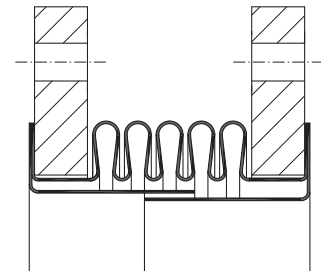

Axial expansion joint with telescopic internal guide sleeve

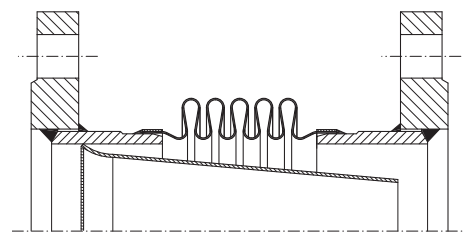

Lateral expansion joint with conical internal guide sleeve

STEEL EXPANSION JOINTS

GENERAL DESCRIPTION OF STEEL EXPANSION JOINTS

GUIDE SLEEVES

Guide sleeves stabilize the expansion joint in its axial movement and prevent it from buckling. As a rule, guide sleeves are made of thick-walled, stainless or unalloyed steel.

Axial expansion joints with two bellows are provided with guide sleeves in the factory, as a rule with a telescopic design.

Expansion joint guide sleeves do not supersede pipe guide bearings.

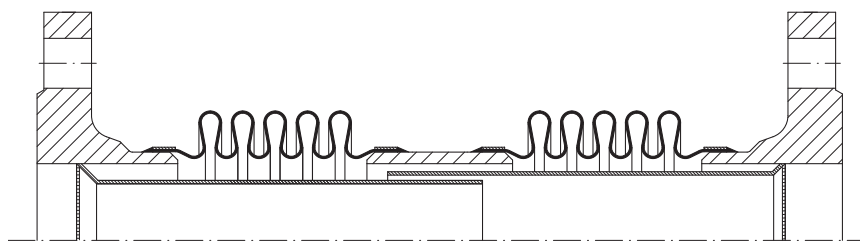

Direction of flow →

Axial expansion joint with telescopic guide sleeve

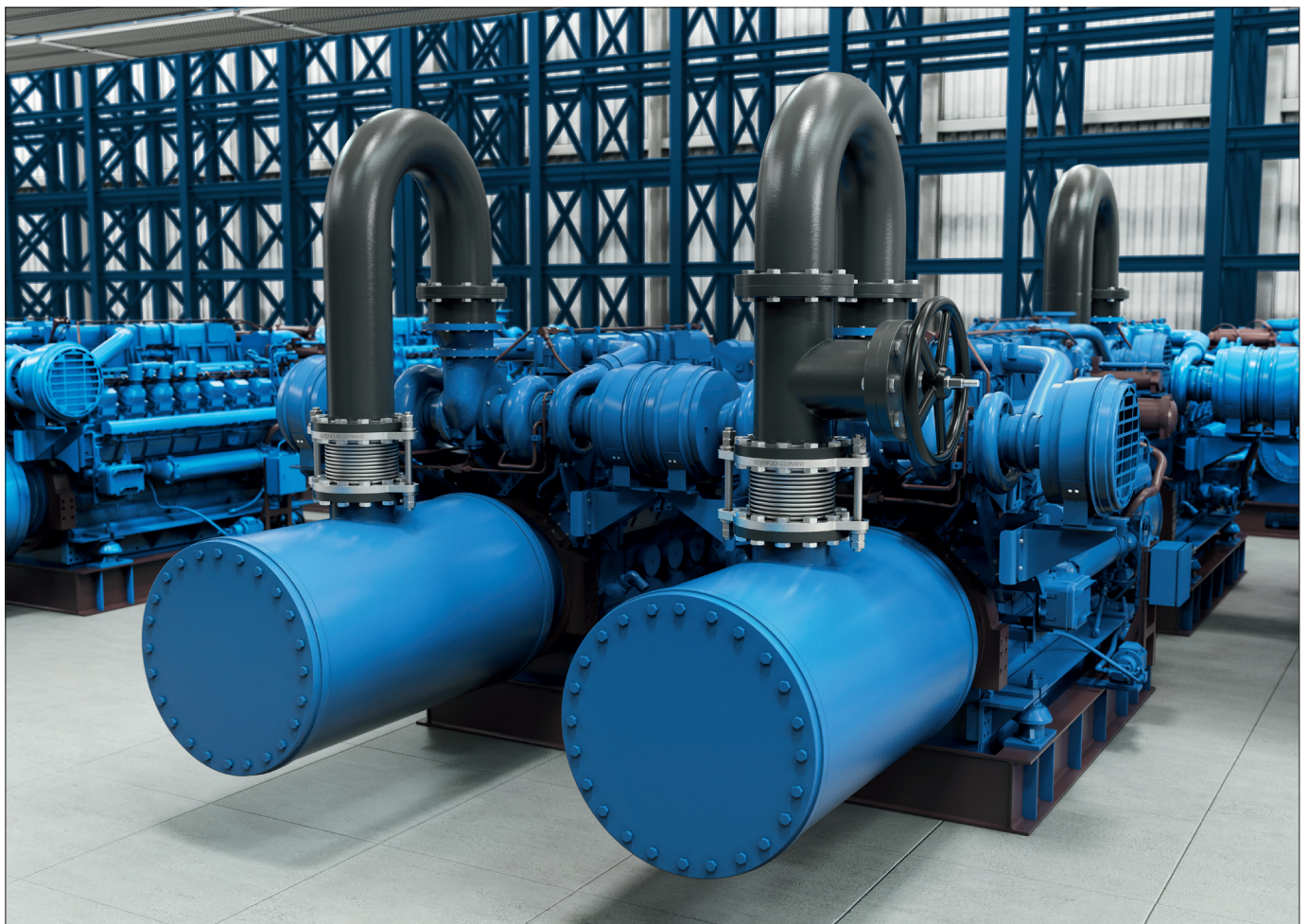

Restrained STENFLEX® stainless steel expansion joints type SF20 / SF21 to absorb thermal expansion in a transformer plant

STEEL EXPANSION JOINTS

COMPENSATION SYSTEMS

With 50 years of experience in expansion joint engineering, STENFLEX® is the competent partner for application-oriented solutions.

STENFLEX® compensation pipe pieces can be supplied on request as complete system solution with ready mounted expansion joints. As a rule, these are angular and lateral expansion joints, designed according to customer requirements.

Pipe sections, bends, T-pieces and expansion joints are put together with the

necessary restraints, hinges, and accessories, to form a unit.

Our experts assist in the selection and optimum arrangement of the system components to produce a compensation system ready to be installed.

COMPENSATION SYSTEMS WITH LATERAL AND ANGULAR EXPANSION JOINTS

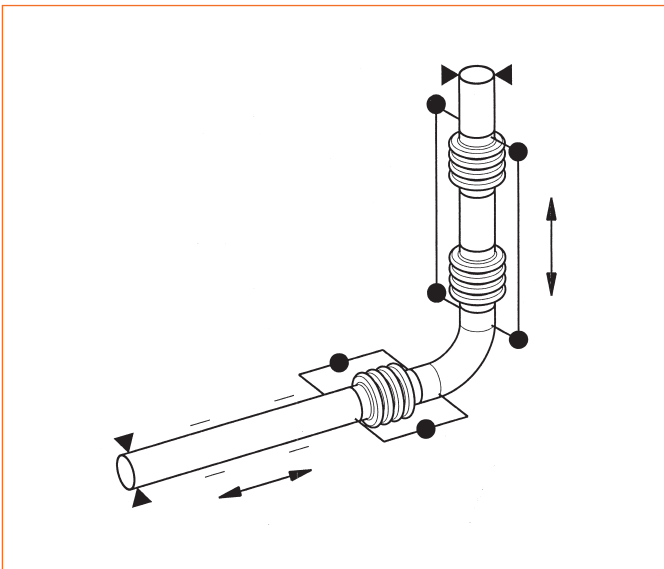

L-shaped triple joint
1 angular and 1 lateral expansion joint with hinge restraints

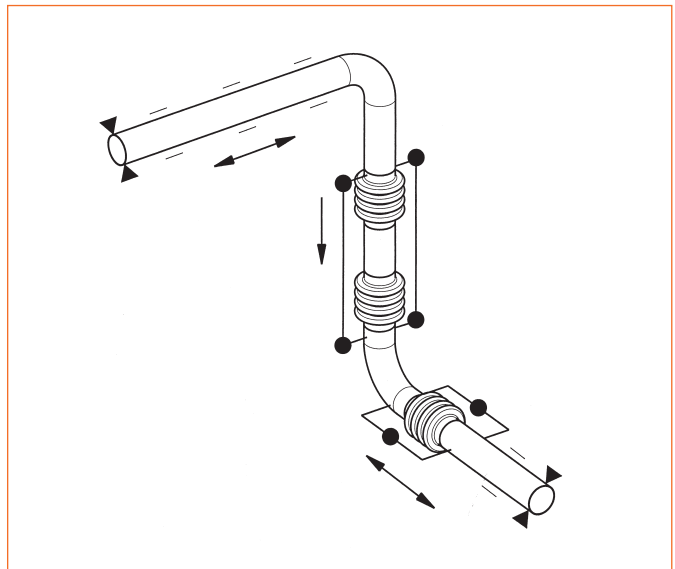

3D triple joint
1 angular and 1 lateral expansion joint with tie rod restraints

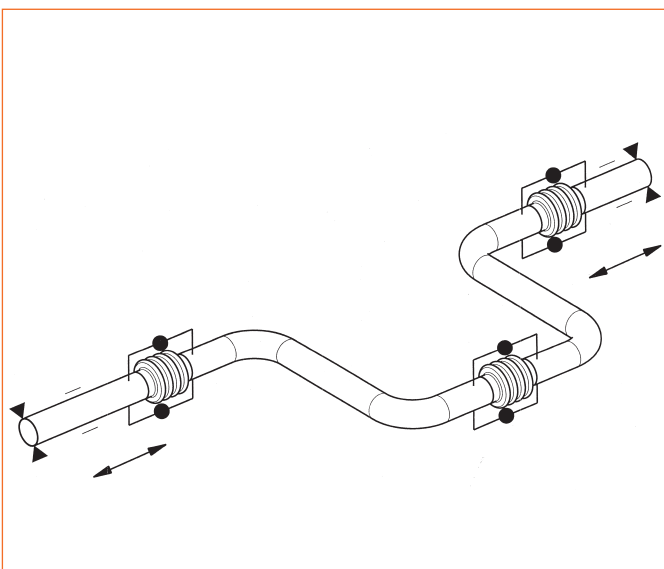

U-shaped triple joint
3 angular expansion joints with hinge restraints

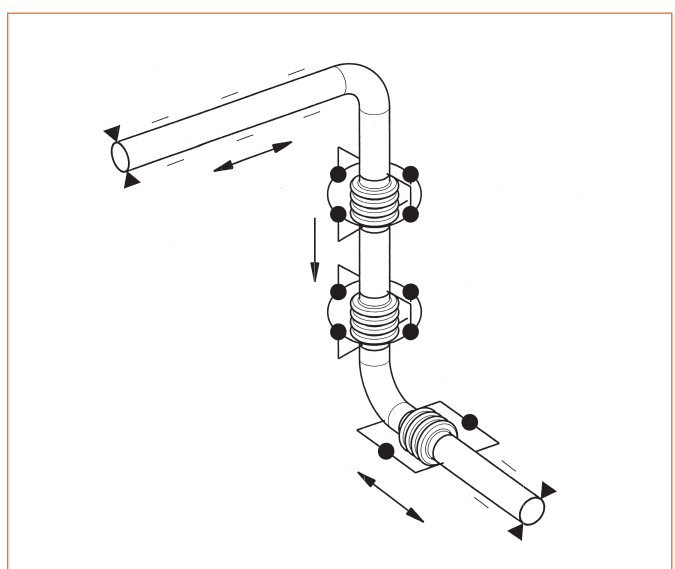

3D triple joint
2 angular expansion joints with cardan hinge restraint and 1 angular expansion joint with hinge restraint



STEEL EXPANSION JOINTS





APPLICATIONS / POSSIBLE USES / INDUSTRIES

Basic expansion joint types		Axial expansion joints						Lateral expansion joints						Angular expansion joints						
		SF-10	SF-11	SF-13	SA-10	SA-13	SG-10	SG-11	SF-20	SF-21	SF-23	SF-24	SF-25	SA-20	SA-23	SA-24	SA-25	SF-32	SF-33	SA-33
STENFLEX® Expansion joint types																				
Applications	Reducing tension	■	■	■	■	■	■	■	■	■	■	■	■	■	■	■	■	■	■	■
	Absorbing axial movement	■	■	■	■	■	■			■					■					
	Absorbing lateral movement								■	■	■	■	■	■	■	■	■			
	Absorbing angular movement																	■	■	■
	Double or triple joint systems for absorbing large movement																	■	■	■
	Absorbing oscillation	■	■		■		■	■	■	■	■			■	■					
	Muffling sound	■	■		■		■	■	■	■	■			■	■					
	Installation and dismantling aid								■	■										
	Compensating for installation inaccuracies	■	■		■		■	■	■	■	■			■	■	■		■		
Possible uses	Metal pipes	■	■	■	■	■	■	■	■	■	■	■	■	■	■	■	■	■	■	■
	Plastic/copper pipes						■	■												
	Engines	■	■		■				■	■	■			■	■					
	Pumps	■	■						■	■	■			■	■					
	Compressors	■	■		■				■	■	■			■	■					
	Turbines	■	■		■				■	■	■			■	■					
	Heat exchangers	■	■		■				■	■	■			■	■					
	Condensers	■	■						■	■	■				■					
	Separators	■	■		■				■	■				■						
	Biogas plants	■	■		■	■		■	■					■						
	Solar technology	■	■	■	■	■	■	■	■					■						
Industries	Mechanical engineering	■	■		■		■	■	■	■			■	■						
	Domestic industry	■	■	■	■	■	■	■	■				■							
	Heating installation	■	■	■	■	■	■	■	■	■			■	■						
	Chemical industry	■							■											
	Plant construction	■	■	■					■	■	■	■	■		■	■	■	■	■	■
	Power industry		■	■		■			■	■	■	■	■		■	■	■	■	■	■
	Shipbuilding	■	■		■	■			■	■	■			■	■					
	Pipeline construction	■	■	■	■	■			■	■	■	■	■	■	■	■	■	■	■	■
	Hydraulic systems	■			■				■		■		■	■	■		■			
	Printing and paper industry	■	■						■	■										
	Exhaust technology/gas supply systems	■	■		■	■		■	■	■				■	■					
	Water supply and water treatment	■			■		■		■											
	Renewable energy technology	■	■	■	■	■	■	■	■	■				■						

Table showing the prime applications, possible uses and industries.

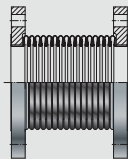
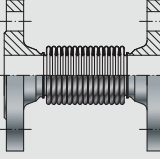
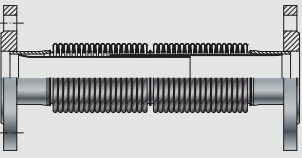
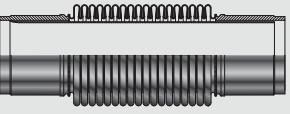
STEEL-EXPANSION JOINTS



PROGRAM SUMMARY

AXIAL STEEL EXPANSION JOINTS							
	Type	DN	Pressure rate bar	Max. operating temperature	Bellows material	Connection parts/restraints	Page
	SF-10	DN 25 – 2800 DN 300 – 2000 DN 15 – 1000 DN 15 – 500 on request on request	PN 2,5 PN 6 PN 10 PN 16	+550 °C +550 °C +550 °C +550 °C +450 °C +900 °C	1.4541, 1.4571, 1.4404 1.4541, 1.4571, 1.4404 1.4541, 1.4571, 1.4404 1.4541, 1.4571, 1.4404 2.4858 1.4828, 1.4878	rotatable flanges	108
	SF-11	DN 15 – 500 DN 200 – 250	PN 16 PN 10	+550 °C +550 °C	1.4541, 1.4571 1.4541, 1.4571	fixed flanges	112
	SF-13	DN 20 – 250 DN 20 – 1200	PN 16	+550 °C +550 °C	1.4541, 1.4571, 1.4404 1.4541, 1.4571, 1.4404	fixed flanges	114
	SA-10	DN 20 – 2800 DN 15 – 2000 DN 15 – 1200 DN 15 – 1000 on request on request	PN 2,5 PN 6 PN 10 PN 16	+550 °C +550 °C +550 °C +550 °C +450 °C +900 °C	1.4541, 1.4571, 1.4404 1.4541, 1.4571, 1.4404 1.4541, 1.4571, 1.4404 1.4541, 1.4571, 1.4404 2.4858 1.4828, 1.4878	welding ends	116
	SA-13	DN 15 – 1200 DN 15 – 250	PN 10 PN 16	+550 °C +550 °C	1.4541, 1.4571, 1.4404 1.4541, 1.4571, 1.4404	welding ends	120
	SG-10	DN 15 – 50	PN 16	+550 °C	1.4541, 1.4571, 1.4404	male thread and hexagon	122
	SG-11	DN 15 – 50	PN 16	+550 °C	1.4541, 1.4571, 1.4404	female thread and hexagon	123

STEEL EXPANSION JOINTS

PROGRAM SUMMARY

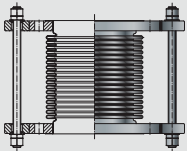
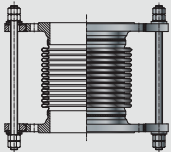
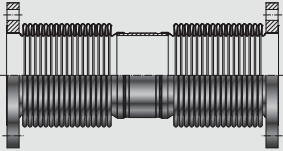
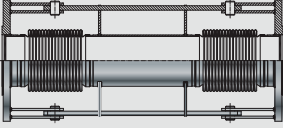
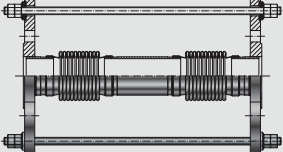
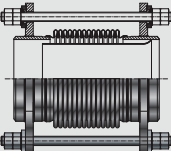
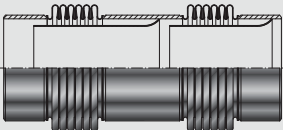
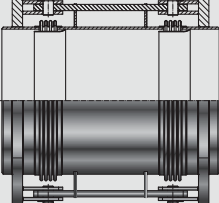
LATERAL STEEL EXPANSION JOINTS

	Type	DN	Pressure rate bar	Max. operating temperature	Bellows material	Connection parts/restraints	Page
	SF-20	DN 32 – 500 DN 32 – 500 on request	PN 10 PN 16	+550 °C +550 °C +900 °C	1.4541, 1.4571, 1.4404 1.4541, 1.4571, 1.4404 1.4828, 1.4878	rotable flanges with tie rod restraints	124
	SF-21	DN 32 – 500	PN 16	+550 °C	1.4541, 1.4571	fixed flanges with tie rod restraints	126
	SF-23	on request	PN 1 PN 6	+550 °C +550 °C	1.4541, 1.4571, 1.4404 1.4541, 1.4571, 1.4404	rotable flanges	128
	SF-24	on request	PN 6 PN 10	+550 °C +550 °C	1.4541, 1.4571, 1.4404 1.4541, 1.4571, 1.4404	fixed flanges with hinge restraints	129
	SF-25	on request	PN 6 PN 10	+550 °C +550 °C	1.4541, 1.4571, 1.4404 1.4541, 1.4571, 1.4404	fixed flanges with tie rod restraints	130
	SA-20	on request	PN 16	+550 °C	1.4541, 1.4571, 1.4404	welding ends with tie rod restraints	131
	SA-23	on request	PN 1 PN 6	+550 °C +550 °C	1.4541, 1.4571, 1.4404 1.4541, 1.4571, 1.4404	welding ends	132
	SA-24	on request	PN 6 PN 10	+550 °C +550 °C	1.4541, 1.4571, 1.4404 1.4541, 1.4571, 1.4404	welding ends with hinge restraints	133
	SA-25	on request	PN 6 PN 10	+550 °C +550 °C	1.4541, 1.4571, 1.4404 1.4541, 1.4571, 1.4404	welding ends with tie rod restraints	134

STEEL EXPANSION JOINTS

PROGRAM SUMMARY

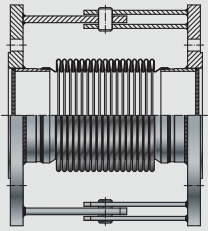
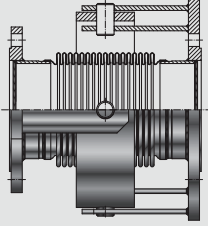
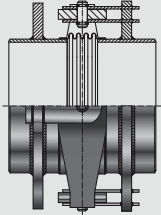
ANGULAR STEEL EXPANSION JOINTS							
	Type	DN	Pressure rate bar	Max. operating temperature	Bellows material	Connection parts/restraints	Page
	SF-32	on request	PN 6 PN 16	+550 °C +550 °C	1.4541, 1.4571, 1.4404 1.4541, 1.4571, 1.4404	fixed flanges with hinge restraints	135
	SF-33	on request	PN 6 PN 16	+550 °C +550 °C	1.4541, 1.4571, 1.4404 1.4541, 1.4571, 1.4404	fixed flanges with cardan-hinge restraints	136
	SA-33	on request	PN 6 PN 16	+550 °C +550 °C	1.4541, 1.4571, 1.4404 1.4541, 1.4571, 1.4404	welding ends with cardan-hinge restraints	137

STEEL-EXPANSION JOINT TYPE SF-10

AXIAL EXPANSION JOINT DN 15 – DN 2800

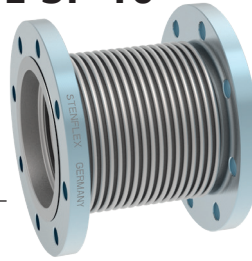

STRUCTURE TYPE SF-10 STEEL BELLOWS PN 2,5, PN 6, PN 10, PN 16

- Vacuum-proof, short-length axial expansion joint, consisting of a stainless steel bellows and rotatable flanges
- Multiple convolution bellows in various stainless steel grades
- Single ply or multi-ply structure
- DN 15 – DN 500 with flared ends
- DN 600 – DN 2800 with pre-welded flared ends

Material grade*	Material No. as per DIN EN	Temperature**	Possible uses
Stainless steel	1.4541	-196 °C up to +550 °C	Low temperature, acids, lyes, gases, fertilizers
	1.4404 1.4571	+550 °C	Media containing chloride, oil, soap, drinking water, food stuff, petrol
Heat-resistant steel	1.4828 1.4878	+900 °C +800 °C	Hot gases, steam, air
Nickel-based alloy	2.4858 (Incoloy 825)	+450 °C	Sulphuric acid, phosphoric acid, petrol, oil, gases

* Check or inquire about the resistance of material grades to temperature and medium.

** Check or inquire about reduction in pressure by temperature.

FLANGES / VERSIONS

- Rotatable flanges
- Flange drilling for through bolts

	Standard		Others
Dimensions	EN 1092		ANSI, BS etc. Connection dimensions see technical annex page 213 – 215
Materials	1.0038 (S235JR), 1.4541, 1.4404		stainless steel etc.
Corrosion protection	DN 32 – DN 250 electro- galvanized	DN 300 – DN 2800 anti-corro- sion primed	hot-dip galvanized, special varnish, special coating etc.

NOTE

Please comply with the general technical instructions regarding reaction force, moving force, fixed point load, installation instructions, etc.

Subject to technical alterations and deviations resulting from the manufacturing process.

APPLICATIONS

- for compensating axial movement
- for reducing tension, damping noise and oscillation in pipes and their system components, e.g.
 - pumps
 - engines
 - machines
- for installation in
 - industrial applications
 - gas and water supply
 - exhaust systems
 - heating installations
 - drinking water systems
- to compensate for installation inaccuracies

SPECIAL DESIGNS

Other sizes (DN), lengths or pressure ratings on request.

CERTIFICATES

- CE (PED 2014/68/EU)
- American Bureau of Shipping
- Bureau Veritas
- DVGW (DN 32 – DN 200)
- DNV GL® / DNV®
- RMRS
- RINA

ACCESSORIES

- Internal guide sleeve
- Protective tube
- Gas sealings for DVGW-application

PRESSURE RATE STANDARD PROGRAM PN 2,5

DN	BL	$\Delta a_{x\text{tot}}^{**}$ Axial movement mm	C_{ax} Axial spring rate N/mm	Δlat_{tot} Lateral movement mm	C_{lat} Lateral spring rate N/mm	A* Effective bellows cross sectional area cm ²	$\varnothing d_4$ Flared end \varnothing mm	$\varnothing D_a$ Bellows outer \varnothing mm	PN Flange connection EN1092	$\varnothing D$ Flange outer \varnothing mm	b Flange thickness mm	Weight approx. kg
25	105	25	28	13	10	10	68	42	16	115	16	3.9
32	135	30	15	26	8	15	56	51	16	140	18	3.8
40	135	30	17	20	15	22	65	61	16	150	18	3.9
50	160	44	16	34	12	34	80	76	16	165	18	5.3
65	175	56	25	26	18	55	95	96	16	185	18	7.0
80	190	68	20	28	18	78	110	114	16	200	20	7.9
100	195	70	19	26	22	114	140	136	16	220	20	10.0
125	200	72	26	21	49	174	165	168	16	250	22	12.3
150	220	80	28	21	62	246	200	197	16	285	24	16.1
200	230	86	36	19	118	424	254	253	10	340	24	20.7
250	245	96	50	19	208	622	310	302	10	395	26	26.1
300	180	48	119	-	-	990	364	386	6	440	24	27.0
300	265	98	60	14	399	990	364	386	6	440	24	30.0
350	185	48	129	-	-	1176	396	418	6	490	26	38.0
350	270	96	65	14	515	1176	396	418	6	490	26	40.0
400	185	46	146	-	-	1507	452	469	6	540	28	44.0
400	270	94	73	12	744	1507	452	469	6	540	28	47.0
450	190	46	162	-	-	1878	498	520	6	595	30	54.0
450	275	92	81	10	1032	1878	498	520	6	595	30	57.0
500	190	44	178	-	-	2282	548	570	6	645	30	58.0
500	275	90	89	8	1378	2282	548	570	6	645	30	62.0
600	195	44	212	-	-	3227	670	672	6	755	32	77.0
600	280	88	106	7	2315	3227	670	672	6	755	32	81.0
700	210	44	246	-	-	4336	775	774	6	860	40	111.0
700	295	88	123	-	-	4336	775	774	6	860	40	116.0
800	220	42	279	-	-	5595	875	875	6	975	44	150.0
800	305	86	140	-	-	5595	875	875	6	975	44	156.0
900	225	42	313	-	-	7014	975	976	6	1075	48	182.0
900	310	86	156	-	-	7014	975	976	6	1075	48	188.0
1000	235	42	346	-	-	8610	1080	1078	6	1175	52	212.0
1000	320	86	173	-	-	8610	1080	1078	6	1175	52	220.0
1200	210	42	413	-	-	12291	1262	1282	2.5	1375	30	152.0
1200	295	84	207	-	-	12291	1262	1282	2.5	1375	30	160.0
1400	210	42	478	-	-	16536	1462	1482	2.5	1575	30	175.0
1400	295	84	239	-	-	16536	1462	1482	2.5	1575	30	185.0
1600	210	42	543	-	-	21408	1662	1682	2.5	1790	30	219.0
1600	295	84	271	-	-	21408	1662	1682	2.5	1790	30	231.0
1800	210	42	607	-	-	26909	1862	1882	2.5	1990	30	245.0
1800	295	84	304	-	-	26909	1862	1882	2.5	1990	30	258.0
2000	210	42	672	-	-	33039	2062	2082	2.5	2190	30	271.0
2000	295	84	336	-	-	33039	2062	2082	2.5	2190	30	285.0
2200	210	42	736	-	-	39796	2262	2282	2.5	2405	35	365.0
2200	295	84	368	-	-	39796	2262	2282	2.5	2405	35	381.0
2400	210	42	800	-	-	47182	2462	2482	2.5	2605	35	387.0
2400	295	84	400	-	-	47182	2462	2482	2.5	2605	35	414.0
2800	210	42	928	-	-	63839	2862	2882	2.5	3030	35	520.0
2800	295	84	464	-	-	63839	2862	2882	2.5	3030	35	540.0

Table values refer to +20 °C, bellows material 1.4541, 1000 cycles. Please inquire for deviating values. For pure axial movement: inner diameter of internal guide sleeve mentioned in tables PN 6, PN 10, PN 16. If Δax and Δlat occur simultaneously, the table values must be reduced accordingly. The sum of all shares must not exceed 100 %.

*Effective bellows cross sectional area is a theoretical value.

**This value represents the total possible movement. Example: $\Delta ax_{tot}=28\text{mm}$. This means that the expansion joint has a total movement value of 28 mm (= +/- 14 mm).

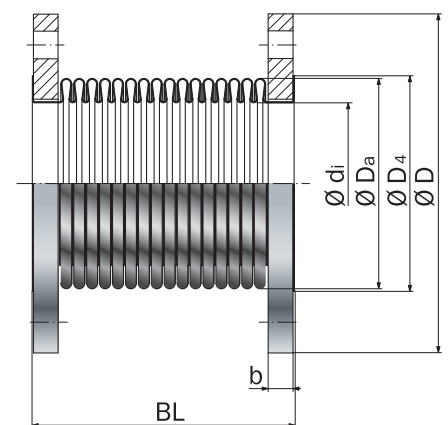

Type SF-10

STEEL EXPANSION JOINT TYPE SF-10

AXIAL EXPANSION JOINT DN 15 – DN 2800

PRESSURE RATE STANDARD PROGRAM PN 6

DN	BL mm	$\Delta a_{x\text{tot}}^{**}$ Axial move- ment mm	C_{ax} Axial spring rate N/mm	A* Effective bellows cross sectional area cm ²	$\varnothing d_4$ Flared end \varnothing mm	$\varnothing D_a$ Bellows outer \varnothing mm	$\varnothing d_i$ Internal guide sleeve \varnothing mm	PN Flange connection EN1092	$\varnothing D$ Flange outer \varnothing mm	b Flange thick- ness mm	Weight approx. kg
300	195	28	455	993	364	387	310	6	440	24	29.0
300	290	58	228	993	364	387	310	6	440	24	33.0
350	200	28	496	1180	396	419	342	6	490	26	40.0
350	295	58	248	1180	396	419	342	6	490	26	44.0
400	200	28	564	1511	452	470	393	6	540	28	47.0
400	300	56	282	1511	452	470	393	6	540	28	51.0
450	205	28	632	1883	498	521	444	6	595	30	57.0
450	305	56	316	1883	498	521	444	6	595	30	62.0
500	205	28	699	2287	548	571	494	6	645	30	62.0
500	305	56	350	2287	548	571	494	6	645	30	68.0
600	210	28	835	3233	670	673	596	6	755	32	81.0
600	310	56	418	3233	670	673	596	6	755	32	88.0
700	230	27	970	4343	775	775	698	6	860	40	116.0
700	325	54	485	4343	775	775	698	6	860	40	124.0
800	225	27	1104	5603	857	876	795	6	975	30	112.0
800	320	55	552	5603	857	876	795	6	975	30	121.0
900	225	27	1236	7023	958	977	896	6	1075	30	125.0
900	320	54	618	7023	958	977	896	6	1075	30	135.0
1000	225	27	1369	8619	1060	1079	998	6	1175	30	135.0
1000	320	54	685	8619	1060	1079	998	6	1175	30	147.0
1200	225	27	1634	12303	1264	1283	1202	6	1405	30	186.0
1200	320	54	817	12303	1264	1283	1202	6	1405	30	200.0
1400	225	27	1894	16549	1464	1483	1402	6	1630	35	275.0
1400	320	54	947	16549	1464	1483	1402	6	1630	35	291.0
1600	225	27	2152	21424	1664	1683	1602	6	1830	35	312.0
1600	320	54	1076	21424	1664	1683	1602	6	1830	35	331.0
1800	225	27	2410	26927	1864	1883	1802	6	2045	35	371.0
1800	320	54	1205	26927	1864	1883	1802	6	2045	35	392.0
2000	225	27	2667	33058	2064	2083	2002	6	2265	35	444.0
2000	320	54	1334	33058	2064	2083	2002	6	2265	35	467.0

Table values refer to +20 °C, bellows material 1.4541, 1000 cycles. Please inquire for deviating values.

*Effective bellows cross sectional area is a theoretical value.

**This value represents the total possible movement. Example: $\Delta a_{x\text{tot}} = 28\text{mm}$. This means that the expansion joint has a total movement value of 28 mm (= +/- 14 mm).

PRESSURE RATE STANDARD PROGRAM PN 10

DN	BL mm	$\Delta a_{x\text{tot}}^{**}$ Axial movement mm	C_{ax} Axial spring rate N/mm	A* Effective bellows cross sectional area cm ²	$\varnothing d_4$ Flared end \varnothing mm	$\varnothing D_a$ Bellows outer \varnothing mm	$\varnothing d_i$ Internal guide sleeve \varnothing mm	PN Flange connection EN1092	$\varnothing D$ Flange outer \varnothing mm	b Flange thick- ness mm	Weight approx. kg
15	108	17	21	7	45	38	18	16	95	14	1.5
20	108	17	21	7	58	38	18	16	105	16	2.1
25	125	26	49	16	54	54	25	16	115	16	2.4
32	135	26	49	16	54	54	32	16	140	18	4.0
40	135	30	111	25	68	66	38	16	150	18	4.5
50	155	36	177	34	75	79	49	16	165	18	5.5
65	165	40	199	54	95	96	63	16	185	18	7.4
80	175	46	148	78	110	115	76	16	200	20	8.4
100	180	46	175	115	140	137	96	16	220	20	10.1
125	200	50	143	173	165	168	123	16	250	22	13.2
150	230	50	160	243	200	197	148	16	285	24	17.3
200	230	38	219	422	254	253	198	10	340	24	22.1
250	245	38	624	620	310	302	249	10	395	26	28.6
300	200	28	455	993	364	387	310	10	445	26	33.0
300	295	56	288	993	364	387	310	10	445	26	36.0
350	205	27	496	1180	396	419	342	10	505	30	50.0
350	305	54	248	1180	396	419	342	10	505	30	54.0
400	210	27	564	1511	452	470	393	10	565	32	62.0
400	310	54	282	1511	452	470	393	10	565	32	67.0
450	220	27	632	1883	498	521	444	10	615	36	76.0
450	315	54	316	1883	498	521	444	10	615	36	81.0
500	225	26	699	2287	548	571	494	10	670	38	90.0
500	320	53	350	2287	548	571	494	10	670	38	96.0
600	225	26	835	3233	654	673	596	10	780	30	90.0
600	320	52	418	3233	654	673	596	10	780	30	97.0
700	225	26	970	4343	756	775	698	10	895	30	112.0
700	320	52	485	4343	756	775	698	10	895	30	120.0
800	225	25	1104	5603	857	876	795	10	1015	30	140.0
800	320	51	552	5603	857	876	795	10	1015	30	149.0
900	225	25	1236	7023	958	977	896	10	1115	30	154.0
900	320	51	618	7023	958	977	896	10	1115	30	164.0
1000	225	25	1369	8619	1060	1078	998	10	1230	35	205.0
1000	320	50	685	8619	1060	1078	998	10	1230	35	217.0

PRESSURE RATE STANDARD PROGRAM PN 16

DN	BL mm	$\Delta a_{x\text{tot}}^{**}$ Axial move- ment mm	C_{ax} Axial spring rate N/mm	A* Effective bellows cross sectional area cm ²	$\varnothing d_4$ Flared end \varnothing mm	$\varnothing D_a$ Bellows outer \varnothing mm	$\varnothing d_i$ Internal guide sleeve \varnothing mm	PN Flange connection EN1092	$\varnothing D$ Flange outer \varnothing mm	b Flange thick- ness mm	Weight approx. kg
15	108	17	21	7	45	38	18	16	95	14	1.5
20	108	17	21	7	58	38	18	16	105	16	2.1
25	125	26	49	16	54	54	25	16	115	16	2.4
32	135	26	49	16	54	54	32	16	140	18	4.0
40	135	30	111	25	68	66	38	16	150	18	4.5
50	155	36	177	34	75	79	49	16	165	18	5.5
65	165	40	199	54	95	96	63	16	185	18	7.4
80	175	46	148	78	110	115	76	16	200	20	8.4
100	180	46	175	115	140	137	96	16	220	20	10.1
125	200	50	79	173	165	168	123	16	250	22	13.2
150	230	50	160	243	200	197	148	16	285	24	17.3
200	230	38	219	422	254	253	198	16	340	26	23.1
250	245	38	624	620	310	302	249	16	405	29	33.3
300	220	22	863	995	364	388	310	16	460	32	44.0
300	320	44	432	995	364	388	310	16	460	32	49.0
350	225	21	946	1182	396	420	342	16	520	35	63.0
350	325	43	473	1182	396	420	342	16	520	35	68.0
400	230	21	1078	1514	452	471	393	16	580	38	80.0
400	330	43	539	1514	452	471	393	16	580	38	85.0
450	240	21	1210	1886	498	522	444	16	640	42	101.0
450	340	43	605	1886	498	522	444	16	640	42	108.0
500	245	21	1338	2290	548	572	494	16	715	46	140.0
500	345	42	669	2290	548	572	494	16	715	46	148.0

Table values refer to +20 °C, bellows material 1.4541, 1000 cycles. Max. allowable pressure pulsation of 1.0 bar (brief periods). Please inquire for deviating values. *Effective bellows cross sectional area is a theoretical value. **This value represents the total possible movement. Example:

$\Delta a_{x\text{tot}} = 28\text{mm}$. This means that the expansion joint has a total movement value of 28 mm (= +/- 14 mm).

www.stenflex.com / info@stenflex.com

STEEL EXPANSION JOINT TYPE SF-11

AXIAL EXPANSION JOINT DN 15 – DN 500



STRUCTURE TYPE SF-11, STEEL BELLOWS PN 16

- Vacuum-proof axial expansion joint consisting of a stainless steel bellows and welded flanges
- Multiple convolution bellows in various stainless steel grades
- Single ply or multi-ply structure

Material grade*	Material No. as per DIN EN	Temperature**	Possible uses
Stainless steel	1.4541	-196 °C up to +550 °C	Low temperature, acids, lyes, gases, fertilizers
	1.4404 1.4571	+550 °C	Media containing chloride, oil, soap, drinking water, food stuff, petrol

* Check or inquire about the resistance of material grades to temperature and medium.

** Check or inquire about reduction in pressure by temperature.

FLANGES / VERSIONS

- Welded flanges with turned seal
- Flange drilling for through bolts

	Standard	Others
Dimensions	EN 1092	ANSI, BS etc. Connection dimensions see technical annex page 213 – 215
Materials	1.0038 (S235JR), 1.0460 (P250GH)	stainless steel etc.
Corrosion protection	anti-corrosion primed	special varnish etc.

NOTE

Please comply with the general technical instructions regarding reaction force, moving force, fixed point load, installation instructions, etc.

Subject to technical alterations and deviations resulting from the manufacturing process.

APPLICATIONS

- for compensating axial movement
- for reducing tension, in pipes and their system components, e.g.
 - pumps
 - compressors
 - engines
 - turbines
 - machines
 - process plants
- for installation in
 - industrial applications
 - gas and water supply
 - exhaust systems
 - heating installations
- to compensate for installation inaccuracies

GUIDE SLEEVE

Materials

Standard: 1.4541

SPECIAL DESIGN

Other sizes (DN), lengths or pressure ratings on request.

CERTIFICATES

- CE (PED 2014/68/EU)
- American Bureau of Shipping
- Bureau Veritas
- DVGW (DN 32 – DN 200)
- DNV GL® / DNV®
- RMRS
- Rina

ACCESSORIES

- internal guide sleeve
- Protective tube
- Gas sealings for DVGW-application

PRESSURE RATE STANDARD PROGRAM PN 16

DN	BL mm	$\Delta a_{x\text{tot}}^{**}$ Axial movement mm	C_{ax} Axial spring rate N/mm	A* Effective bellows cross sectional area cm ²	$\varnothing D_a$ Bellows outer \varnothing mm	$\varnothing d_i$ Internal guide sleeve \varnothing mm	PN Flange connection EN1092	$\varnothing D$ Flange outer \varnothing mm	b Flange thick- ness mm	Weight approx. kg
15	100	20	30	7	36	14	16	95	14	1.5
20	100	20	30	7	36	18	16	105	16	2.0
25	105	25	28	10	42	24	16	115	16	2.4
32	150	20	49	16	54	32	16	140	18	3.9
40	175	26	132	25	66	38	16	150	18	4.3
50	205	32	197	36	79	49	16	165	18	5.3
65	210	36	221	54	96	64	16	185	20	6.4
80	225	38	188	78	115	77	16	200	20	8.2
100	235	42	175	115	137	96	16	220	20	9.7
125	265	50	79	173	168	123	16	250	22	14.0
150	290	50	156	243	197	150	16	285	22	17.2
200	310	38	237	422	253	199	16	340	24	24.9
250	335	38	624	620	302	250	16	405	26	36.0
300	260	22	863	995	388	299	16	460	28	50.0
300	410	52	379	990	386	299	16	460	28	57.0
350	265	21	946	1182	420	329	16	520	30	72.0
350	415	54	379	1182	420	329	16	520	30	79.0
400	270	21	1078	1514	471	380	16	580	32	90.0
400	420	54	431	1514	471	380	16	580	32	98.0
450	270	21	1210	1886	522	431	16	640	34	105.0
450	420	53	484	1886	522	431	16	640	34	115.0
500	270	21	1338	2290	572	482	16	715	36	136.0
500	420	53	535	2290	572	482	16	715	36	147.0

For larger sizes (DN) please see type SF-16. Also available with PN 10 flange connection.

Table values refer to +20 °C, bellows material 1.4541, 1000 cycles.

Max. allowable pressure pulsation of 1.6 bar (brief periods). Please inquire for deviating values.

*Effective bellows cross sectional area is a theoretical value.

**This value represents the total possible movement. Example: $\Delta a_{x\text{tot}} = 28\text{mm}$. This means that the expansion joint has a total movement value of 28 mm (= +/- 14 mm).

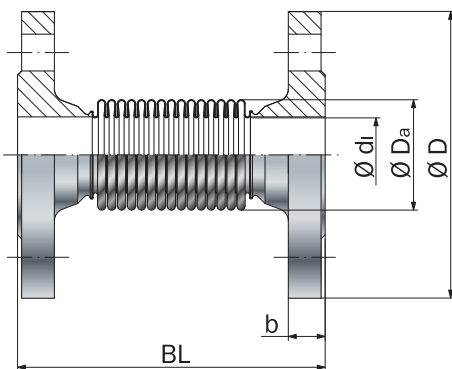

DN 15 - DN 32

Type SF-11 without inner guide sleeve

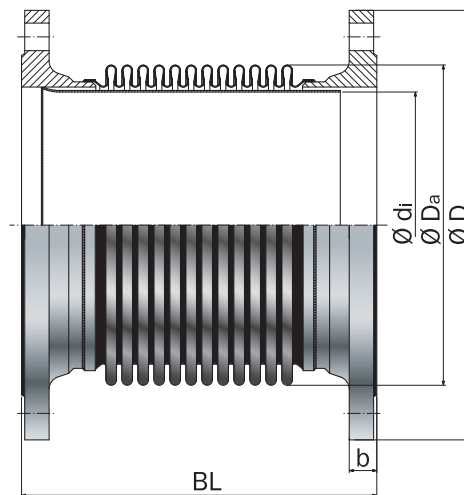

DN 40 - DN 500

Type SF-11 with inner guide sleeve

STEEL EXPANSION JOINT TYPE SF-13

AXIAL EXPANSION JOINT DN 20 – DN 1200



STRUCTURE TYPE SF-13 / STEEL BELLOWS PN 10, 16

- Vacuum-proof axial expansion joint consisting of two stainless steel bellows (DN 125 – DN 1200 with connecting pipe) and welded flanges
- Guide sleeves to stabilize the expansion joint
- Guide sleeves do not supersede pipe guide bearings
- Multiple convolution bellows in various stainless steel grades
- Single ply or multi-ply structure

Material grade*	Material No. as per DIN EN	Temperature**	Possible uses
Stainless steel	1.4541	-196 °C up to +550 °C	Low temperature, acids, lyes, gases, fertilizers
	1.4404 1.4571	+550 °C	Media containing chloride, oil, soap, drinking water, food stuff, petrol

* Check or inquire about the resistance of material grades to temperature and medium.

** Check or inquire about reduction in pressure by temperature.

FLANGES / VERSIONS

- Welded flanges, up to DN 250 with turned seal
- Flange drilling for through bolts

	Standard	Others
Dimensions	EN 1092	ANSI, BS etc. Connection dimensions see technical annex page 213 – 215
Materials	1.0038 (S235JR)	stainless steel etc.
Corrosion protection	anti-corrosion primed	special varnish etc.

NOTE

Please comply with the general technical instructions regarding reaction force, moving force, fixed point load, installation instructions, etc.

Subject to technical alterations and deviations resulting from the manufacturing process.

APPLICATIONS

- for compensating large axial movement
- for installation in
 - long pipe routings
 - industrial applications
 - heating installations

CONNECTING PIPE

Materials

Standard: 1.0345 (P235GH),
1.0038 (S235JR), 1.4541

Others: stainless steel etc.

Corrosion protection

Standard: anti-corrosion primed

Others: special varnish etc.

GUIDE SLEEVE

Materials

Standard: 1.4541

SPECIAL DESIGN

Other sizes (DN), lengths or pressure ratings on request.

CERTIFICATES

- CE (PED 2014/68/EU)

ACCESSORIES

- Protective tube

PRESSURE RATE STANDARD PROGRAM PN 10

DN	BL	$\Delta a_{x\text{tot}}^{**}$ Axial movement mm	C_{ax} Axial spring rate N/mm	A* Effective bellows cross sectional area cm ²	$\varnothing D_a$ Bellows outer \varnothing mm	$\varnothing d_i$ Internal guide sleeve \varnothing mm	PN Flange connection EN1092	$\varnothing D$ Flange outer \varnothing mm	b Flange thickness mm	Weight approx. kg
20	270	48	25	7	38	18	16	105	16	2.2
25	285	40	25	16	54	24	16	115	16	2.9
32	285	40	25	16	54	32	16	140	16	3.9
40	320	52	34	25	66	37	16	150	16	4.6
50	340	68	44	36	79	47	16	165	18	6.2
65	380	72	51	54	96	60	16	185	18	8.3
80	380	80	40	78	116	74	16	200	20	10.4
100	410	80	46	115	136	95	16	220	20	11.6
125	495	100	40	173	168	116	16	250	22	18.0
150	555	100	78	243	196	145	16	285	22	23.0
200	565	76	119	422	253	193	10	340	26	35.2
250	570	104	312	620	302	246	10	395	29	46.0
300	750	140	91	993	387	291	10	445	26	91.0
350	750	138	99	1180	419	323	10	505	30	112.0
400	750	136	113	1511	470	373	10	565	32	126.0
450	750	134	126	1883	521	424	10	615	36	159.0
500	750	132	140	2287	571	475	10	670	38	183.0
600	750	132	167	3233	673	577	10	780	42	225.0
700										
800										
900										
1000	on request	on request	on request	on request	on request	on request	on request	on request	on request	on request
1200										

PRESSURE RATE STANDARD PROGRAM PN 16

DN	BL	$\Delta a_{x\text{tot}}^{**}$ Axial movement mm	C_{ax} Axial spring rate N/mm	A* Effective bellows cross sectional area cm ²	$\varnothing D_a$ Bellows outer \varnothing mm	$\varnothing d_i$ Internal guide sleeve \varnothing mm	PN Flange connection EN1092	$\varnothing D$ Flange outer \varnothing mm	b Flange thickness mm	Weight approx. kg
20	270	48	25	7	38	18	16	105	16	2.2
25	285	40	25	16	54	24	16	115	16	2.9
32	285	40	25	16	54	32	16	140	16	3.9
40	320	52	34	25	66	37	16	150	16	4.6
50	340	68	44	36	79	47	16	165	18	6.2
65	380	72	51	54	96	60	16	185	18	8.3
80	380	80	40	78	116	74	16	200	20	10.4
100	410	80	46	115	136	95	16	220	20	11.6
125	495	100	40	173	168	116	16	250	22	18.0
150	555	100	78	243	196	145	16	285	22	23.0
200	565	76	119	422	253	193	16	340	26	35.2
250	570	104	312	620	302	246	16	405	29	47.9

Table values refer to +20 °C, bellows material 1.4541, 1000 cycles. Max. allowable pressure pulsation of 1.0 bar (brief periods).

Please inquire for deviating values. *Effective bellows cross sectional area is a theoretical value. **This value represents the total possible movement.

Example: $\Delta a_{x\text{tot}} = 28\text{mm}$. This means that the expansion joint has a total movement value of 28 mm (= +/- 14 mm).

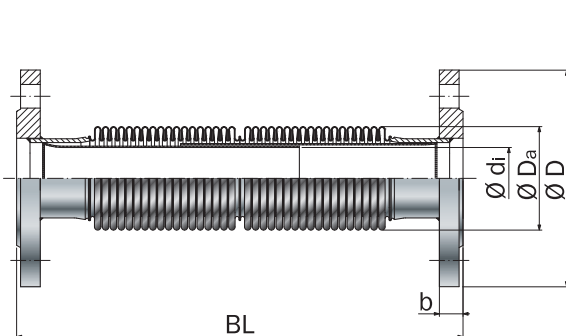

DN 15 - DN 100

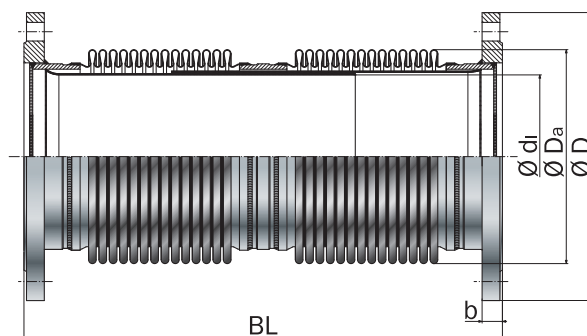

DN 125 - DN 250

Type SF-13 with inner guide sleeve

STEEL EXPANSION JOINT TYPE SA-10

AXIAL EXPANSION JOINT DN 15 – DN 2800



STRUCTURE TYPE SA-10 STEEL BELLOWS PN 2,5, PN 6, PN 10, PN 16

- Vacuum-proof axial expansion joint consisting of a stainless steel bellows and welded pipe ends (welding ends)
- Multiple convolution bellows in various stainless steel grades
- Single ply or multi-ply structure

Material grade*	Material No. as per DIN EN	Temperature**	Possible uses
Stainless steel	1.4541	-196 °C up to +550 °C	Low temperature, acids, lyes, gases, fertilizers
	1.4404 1.4571	+550 °C	Media containing chloride, oil, soap, drinking water, food stuff, petrol
Heat-resistant steel	1.4828 1.4878	+900 °C +800 °C	Hot gases, steam, air
Nickel-based alloy	2.4858 (Incoloy 825)	+450 °C	Sulphuric acid, phosphoric acid, petrol, öl, gases

* Check or inquire about the resistance of material grades to temperature and medium.

** Check or inquire about reduction in pressure by temperature.

WELDING ENDS / VERSIONS

- Welded pipe ends

	Standard	Others
Dimensions	see tables page 117 – 119	on request
Materials	1.0345 (P235GH), 1.0038 (S235JR), 1.4541	stainless steel etc.
Corrosion protection	anti-corrosion primed	special varnish etc.

NOTE

Please comply with the general technical instructions regarding reaction force, moving force, fixed point load, installation instructions, etc.

Subject to technical alterations and deviations resulting from the manufacturing process.

APPLICATIONS

- for compensating axial movement
- for reducing tension, damping noise and oscillation in pipes and their system components, e.g.
 - compressors
 - engines
 - turbines
 - machines
 - process plants
- for installation in
 - industrial applications
 - exhaust systems
 - heating installations
 - gas supply lines

SPECIAL DESIGN

Other sizes (DN), lengths or pressure ratings on request.

CERTIFICATES

- CE (PED 2014/68/EU)
- American Bureau of Shipping
- Bureau Veritas
- DVGW (DN 32 – DN 200)
- RINA

ACCESSORIES

- Internal guide sleeve
- Protective tube

PRESSURE RATE STANDARD PROGRAM PN 2,5

DN	BL	$\Delta a_{x\text{tot}}^{**}$ Axial movement mm	C_{ax} Axial spring rate N/mm	Δlat_{tot} Lateral move- ment mm	C_{lat} Lateral spring rate N/mm	A* Effective bellows cross sectional area cm ²	$\emptyset D_a$ Bellows outer \emptyset mm	$\emptyset d_a \times s$ Pipe connection mm	Weight approx. kg
20	175	20	30	11	15	7	36	26.9x2.3	0.2
25	185	25	28	13	17	10	42	33.7x2.6	0.4
32	185	28	16	22	12	15	51	42.4x2.6	0.5
40	190	30	17	20	15	22	61	48.3x2.6	0.6
50	205	40	18	20	17	34	76	60.3x2.9	0.7
65	230	52	23	20	22	55	96	76.1x2.9	1.1
80	240	60	22	22	26	75	114	88.9x3.2	1.5
100	240	64	20	20	30	114	136	114.3x4.0	1.6
125	270	72	26	21	49	174	168	139.7x4.0	2.8
150	300	80	28	21	62	246	197	168.3x4.5	3.8
200	300	86	36	19	118	424	253	219.1x6.3	5.5
250	300	96	50	19	208	622	302	273.0x6.3	6.1
300	245	49	119			990	386	323.9x8.0	13.0
300	370	122	48	24	204	990	386	323.9x8.0	16.0
350	245	48	129			1176	418	355.6x8.0	14.0
350	370	120	52	21	264	1176	418	355.6x8.0	18.0
400	245	47	146			1507	469	406.4x8.0	17.0
400	370	118	58	18	381	1507	469	406.4x8.0	21.0
450	245	46	162			1878	520	457x8.0	19.0
450	370	116	65	16	528	1878	520	457x8.0	23.0
500	245	45	178			2282	570	508x8.0	21.0
500	370	114	71	14	705	2282	570	508x8.0	26.0
600	245	44	212			3227	672	610x8.0	25.0
600	370	112	85	12	1185	3227	672	610x8.0	31.0
700	245	44	246			4336	774	711x8.0	29.0
700	370	110	98	10	1847	4336	774	711x8.0	37.0
800	245	43	279			5595	875	813x8.0	34.0
800	370	109	112	9	2707	5595	875	813x8.0	42.0
900	245	43	313			7014	976	914x10.0	45.0
900	370	109	125	8	3799	7014	976	914x10.0	54.0
1000	245	43	346			8610	1078	1016x10.0	50.0
1000	370	108	138	7	5164	8610	1078	1016x10.0	61.0
1200	245	42	413			12291	1282	1219x10.0	60.0
1200	370	107	165			12291	1282	1219x10.0	73.0
1400	245	42	478			16536	1482	1420x10.0	70.0
1400	370	106	191			16536	1482	1420x10.0	85.0
1600	245	42	543			21408	1682	1620x10.0	80.0
1600	370	106	217			21408	1682	1620x10.0	97.0
1800	245	42	607			26909	1882	1820x10.0	90.0
1800	370	106	243			26909	1882	1820x10.0	109.0
2000	245	42	672			33039	2082	2020x10.0	100.0
2000	370	106	269			33039	2082	2020x10.0	121.0
2200	245	42	736			39796	2282	2220x10.0	110.0
2200	370	106	294			39796	2282	2220x10.0	133.0
2400	245	42	800			47182	2482	2420x10.0	120.0
2400	370	106	320			47182	2482	2420x10.0	145.0
2800	245	42	928			63839	2882	2820x10.0	139.0
2800	370	105	371			63839	2882	2820x10.0	169.0

Table values refer to +20 °C, bellows material 1.4541, 1000 cycles. Max. allowable pressure pulsation of 0.25 bar (brief periods). Please inquire for deviating values. For pure axial movement: inner diameter of internal guide sleeve mentioned in tables PN 6, PN 10, PN 16. If D_{ax} and D_{lat} occur simultaneously, the table values must be reduced accordingly. The sum of all shares must not exceed 100 %. *Effective bellows cross sectional area is a theoretical value. **This value represents the total possible movement. Example: $\Delta a_{x\text{tot}} = 28\text{mm}$. This means that the expansion joint has a total movement value of 28 mm (= +/- 14 mm).

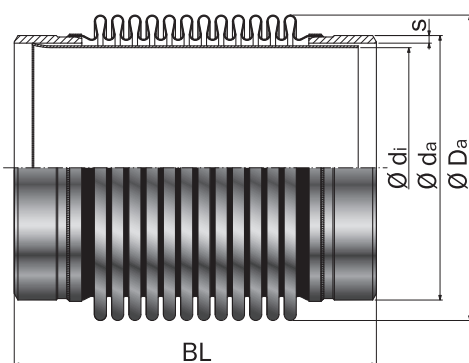

DN 125 - DN 2800

Type SA-10 with inner guide sleeve

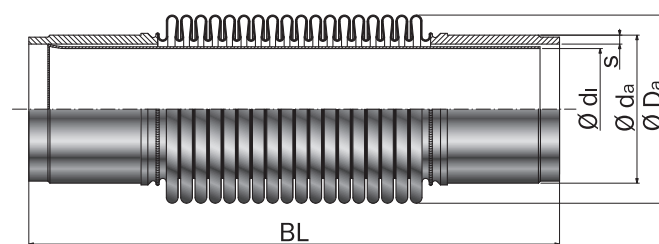

DN 15 - DN 100

STEEL EXPANSION JOINT TYPE SA-10

AXIAL EXPANSION JOINT DN 15 – DN 2800

PRESSURE RATE STANDARD PROGRAM PN 6

DN	BL mm	$\Delta a_{x\text{tot}}^{**}$ Axial movement mm	C_{ax} Axial spring rate N/mm	A* Effective bellows cross sectional area cm ²	$\varnothing D_a$ Bellows outer \varnothing mm	$\varnothing d_i$ Internal guide sleeve \varnothing mm	$\varnothing d_a \times s$ Pipe connection mm	Weight approx. kg
15	175	24	49	7	38	14	21,3x2,0	0,4
20	175	24	49	7	38	18	26,9x2,3	0,4
25	185	20	49	16	54	24	33,7x2,6	0,6
32	185	20	49	16	54	32	42,4x2,9	0,5
40	190	26	67	25	66	37	48,3x2,6	0,6
50	205	34	87	36	79	51	60,3x2,9	0,8
65	230	36	102	54	96	64	76,1x2,9	1,4
80	230	40	80	78	116	78	88,9x3,2	1,9
100	240	40	91	115	136	99	114,3x4,0	2,1
125	270	50	79	173	168	123	139,7x4,0	3,6
150	300	50	156	243	196	150	168,3x4,5	4,8
200	300	38	237	422	253	199	219,1x6,3	6,8
250	300	38	624	620	302	251	273,0x6,3	8,3
300	255	29	455	993	387	294	323,9x8,0	13
300	400	74	182	993	387	294	323,9x8,0	20
350	255	29	496	1180	419	326	355,6x8,0	14
350	400	73	199	1180	419	326	355,6x8,0	22
400	255	28	564	1511	470	376	406,4x8,0	17
400	400	72	226	1511	470	376	406,4x8,0	25
450	255	28	632	1883	521	427	457x8,0	19
450	400	71	253	1883	521	427	457x8,0	29
500	255	28	699	2287	571	478	508x8,0	21
500	400	71	280	2287	571	478	508x8,0	25
600	255	28	835	3233	673	580	610x8,0	25
600	400	70	334	3233	673	580	610x8,0	30
700	255	27	970	4343	775	681	711x8,0	29
700	400	69	388	4343	775	681	711x8,0	36
800	255	27	1104	5603	876	783	813x8,0	33
800	400	69	442	5603	876	783	813x8,0	41
900	255	27	1236	7023	977	880	914x10,0	44
900	400	68	495	7023	977	880	914x10,0	53
1000	255	27	1369	8619	1079	982	1016x10,0	55
1000	400	68	548	8619	1079	982	1016x10,0	72
1200	255	27	1634	12303	1283	1185	1219x10,0	66
1200	400	68	654	12303	1283	1185	1219x10,0	87
1400	255	27	1894	16549	1483	1386	1420x10,0	77
1400	400	68	757	16549	1483	1386	1420x10,0	101
1600	255	27	2152	21424	1683	1586	1620x10,0	88
1600	400	67	861	21424	1683	1586	1620x10,0	116
1800	255	27	2410	26927	1883	1786	1820x10,0	99
1800	400	67	964	26927	1883	1786	1820x10,0	130
2000	255	27	2667	33058	2083	1986	2020x10,0	110
2000	400	67	1067	33058	2083	1986	2020x10,0	144

Table values refer to +20 °C, bellows material 1.4541, 1000 cycles. Max. allowable pressure pulsation of 0.6 bar (brief periods).

Please inquire for deviating values. *Effective bellows cross sectional area is a theoretical value. **This value represents the total possible movement.

Example: $\Delta a_{x\text{tot}} = 28\text{mm}$. This means that the expansion joint has a total movement value of 28 mm (= +/- 14 mm).

PRESSURE RATE STANDARD PROGRAM PN 10

DN	BL mm	$\Delta a_{x_{tot}}^{**}$ Axial movement mm	C_{ax} Axial spring rate N/mm	A* Effective bellows cross sectional area cm ²	$\emptyset D_a$ Bellows outer \emptyset mm	$\emptyset d_i$ Internal guide sleeve \emptyset mm	$\emptyset d_a \times s$ Pipe connection mm	Weight approx. kg
15	175	24	49	7	38	14	21.3x2.0	0.4
20	175	24	49	7	38	18	26.9x2.3	0.4
25	185	20	49	16	54	24	33.7x2.6	0.6
32	185	20	49	16	54	32	42.4x2.9	0.5
40	190	26	67	25	66	37	48.3x2.6	0.6
50	205	34	87	36	79	51	60.3x2.9	0.8
65	230	36	102	54	96	64	76.1x2.9	1.4
80	230	40	80	78	116	78	88.9x3.2	1.9
100	240	40	91	115	136	99	114.3x4.0	2.1
125	270	50	79	173	168	123	139.7x4.0	3.6
150	300	50	156	243	196	150	168.3x4.5	4.8
200	300	38	237	422	253	199	219.1x6.3	6.8
250	300	38	624	620	302	251	273.0x6.3	8.3
300	255	28	455	993	387	294	323.9x8.0	16
300	400	62	220	982	383	294	323.9x8.0	20
350	255	27	496	1180	419	326	355.6x8.0	17
350	400	66	218	1174	417	326	355.6x8.0	22
400	255	27	564	1511	470	376	406.4x8.0	20
400	400	67	226	1511	470	376	406.4x8.0	25
450	255	27	632	1883	521	427	457x8.0	22
450	400	67	253	1883	521	427	457x8.0	29
500	255	26	699	2287	571	478	508x8.0	25
500	400	66	280	2287	571	478	508x8.0	32
600	255	26	835	3233	673	580	610x8.0	30
600	400	66	334	3233	673	580	610x8.0	38
700	255	26	970	4343	775	681	711x8.0	33
700	400	65	388	4343	775	681	711x8.0	45
800	255	25	1104	5603	876	783	813x8.0	37
800	400	64	442	5603	876	783	813x8.0	51
900	255	25	1236	7023	977	880	914x10.0	49
900	400	64	495	7023	977	880	914x10.0	65
1000	255	25	1369	8619	1079	982	1016x10.0	55
1000	400	64	548	8619	1079	982	1016x10.0	72
1200	260	21	3135	12311	1284	1185	1219x10.0	70
1200	410	54	1254	12311	1284	1185	1219x10.0	96

PRESSURE RATE STANDARD PROGRAM PN 16

DN	BL mm	$\Delta a_{x_{tot}}^{**}$ Axial movement mm	C_{ax} Axial spring rate N/mm	A* Effective bellows cross sectional area cm ²	$\emptyset D_a$ Bellows outer \emptyset mm	$\emptyset d_i$ Internal guide sleeve \emptyset mm	$\emptyset d_a \times s$ Pipe connection mm	Weight approx. kg
15	175	24	49	7	38	14	21.3x2.0	0.4
20	175	24	49	7	38	18	26.9x2.3	0.4
25	185	20	49	16	54	24	33.7x2.6	0.6
32	185	20	49	16	54	32	42.4x2.9	0.5
40	190	26	67	25	66	37	48.3x2.6	0.6
50	205	34	87	36	79	51	60.3x2.9	0.8
65	230	36	102	54	96	64	76.1x2.9	1.4
80	230	40	80	78	116	78	88.9x3.2	1.9
100	240	40	91	115	136	99	114.3x4.0	2.1
125	270	50	79	173	168	123	139.7x4.0	3.6
150	300	50	156	243	196	150	168.3x4.5	4.8
200	300	38	237	422	253	199	219.1x6.3	6.8
250	300	38	624	620	302	251	273.0x6.3	8.3
300	260	22	863	995	388	294	323.9x8.0	16
300	410	52	379	990	386	294	323.9x8.0	22
350	260	21	946	1182	420	326	355.6x8.0	17
350	410	54	379	1182	420	326	355.6x8.0	25
400	260	21	1078	1514	471	376	406.4x8.0	20
400	410	54	431	1514	471	376	406.4x8.0	28
450	260	21	1210	1886	522	427	457.0x8.0	22
450	410	53	484	1886	522	427	457.0x8.0	32
500	260	21	1338	2290	572	478	508.0x8.0	25
500	410	53	535	2290	572	478	508.0x8.0	36
600	260	21	1600	3237	674	580	610.0x8.0	30
600	410	52	640	3237	674	580	610.0x8.0	43
700	260	20	1860	4347	776	681	711.0x8.0	35
700	410	52	744	4347	776	681	711.0x8.0	50
800	260	20	2115	5608	877	783	813.0x8.0	40
800	410	52	846	5608	877	783	813.0x8.0	58
900	270	22	3486	7044	980	880	914.0x10.0	53
900	430	56	1394	7044	980	880	914.0x10.0	83
1000	270	22	3860	8643	1082	982	1016.0x10.0	59
1000	430	56	1544	8643	1082	982	1016.0x10.0	92

Table values refer to +20 °C, bellows material 1.4541, 1000 cycles. Max. allowable pressure pulsation of 0.6 bar (brief periods). Please inquire for deviating values. *Effective bellows cross sectional area is a theoretical value. **This value represents the total possible movement. Example:

$\Delta a_{x_{tot}} = 28$ mm. This means that the expansion joint has a total movement value of 28 mm (= +/- 14 mm).

www.stenflex.com / info@stenflex.com

STEEL EXPANSION JOINT TYPE SA-13

AXIAL EXPANSION JOINT DN 15 – DN 1200

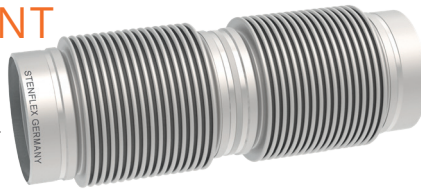

STRUCTURE TYPE SA-13 / STEEL BELLOWS PN 16

- Vacuum-proof axial expansion joint consisting of two stainless steel bellows (DN 125 - DN 1200 with connecting pipe) and welded pipe ends (welding ends)
- Guide sleeves to stabilize the expansion joint
- Guide sleeves do not supersede pipe guide bearings
- Multiple convolution bellows in various stainless steel grades
- Single ply or multi-ply structure

Material grade*	Material No. as per DIN EN	Temperature**	Possible uses
Stainless steel	1.4541	-196 °C up to +550 °C	Low temperature, acids, lyes, gases, fertilizers
	1.4404 1.4571	+550 °C	Media containing chloride, oil, soap, drinking water, food stuff, petrol

* Check or inquire about the resistance of material grades to temperature and medium.

** Check or inquire about reduction in pressure by temperature.

VERSIONS: WELDING ENDS/CONNECTING PIPE

- Welded pipe ends and connecting pipe

	Standard	Others
Dimensions	see tables page 121	on request
Materials	1.0345 (P235GH), 1.0038 (S235JR),	stainless steel etc.
Corrosion protection	anti-corrosion primed	special varnish etc.

NOTE

Please comply with the general technical instructions regarding reaction force, moving force, fixed point load, installation instructions, etc.

Subject to technical alterations and deviations resulting from the manufacturing process.

APPLICATIONS

- for compensating large axial movement
- for installation in
 - long pipe routings
 - industrial applications
 - heating installations
- for gas supply lines

GUIDE SLEEVE

Materials

Standard: 1.4541

SPECIAL DESIGN

Other sizes (DN), lengths or pressure ratings on request.

CERTIFICATES

- CE (PED 2014/68/EU)
- American Bureau of Shipping
- Bureau Veritas
- DVGW (DN 32 – DN 200)
- RINA

ACCESSORIES

- Protective tube

PRESSURE RATE STANDARD PROGRAM PN 16

DN	BL	$\Delta a_{x\text{tot}}^{**}$ Axial movement	C_{ax} Axial spring rate	A* Effective bellows cross sectional area	$\emptyset D_a$ Bellows outer \emptyset mm	$\emptyset d_i$ Internal guide sleeve \emptyset mm	$\emptyset d_a \times s$ Pipe connection	Weight approx. kg
	mm	mm	N/mm	cm ²	mm	mm	mm	
15	260	48	25	7	38	14	21.3x2.0	0.7
20	260	48	25	7	38	18	26.9x2.3	0.7
25	270	40	25	16	54	24	33.7x2.6	1.0
32	270	40	25	16	54	32	42.4x2.9	1.0
40	300	52	34	25	66	37	48.3x2.6	1.1
50	320	68	44	36	79	47	60.3x2.9	1.9
65	357	72	51	54	96	60	76.1x2.9	2.8
80	358	80	40	78	116	74	88.9x3.2	3.6
100	386	80	46	115	136	95	114.3x4.0	4.4
125	475	100	40	173	168	116	139.7x4.0	8.1
150	535	100	78	243	196	145	168.3x4.5	11.0
200	545	76	119	422	253	193	219.1x6.3	17.1
250	545	104	312	620	302	246	273.0x6.3	21.4

Table values refer to +20 °C, bellows material 1.4541, 1000 cycles. Max. allowable pressure pulsation of 1.0 bar (brief periods). Please inquire for deviating values.

*Effective bellows cross sectional area is a theoretical value.

**This value represents the total possible movement. Example: $\Delta a_{x\text{tot}} = 28\text{mm}$. This means that the expansion joint has a total movement value of 28 mm (= +/- 14 mm).

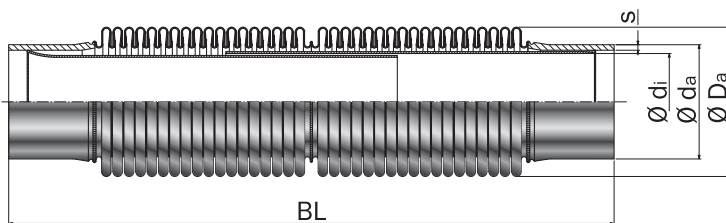

DN 15 - DN 100

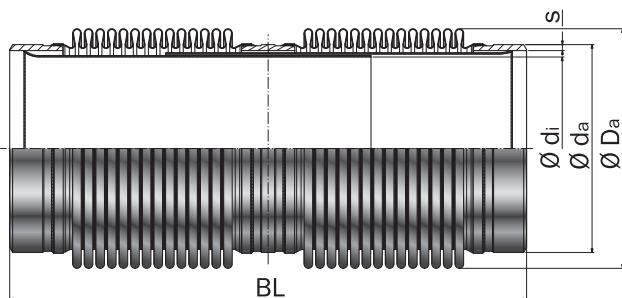

DN 125 - DN 250

Type SA-13 with inner guide sleeve

STEEL EXPANSION JOINT TYPE SG-10

AXIAL EXPANSION JOINT DN 15 – 50 MALE THREAD



STRUCTURE TYPE SG-10 / STEEL BELLOWS PN 16

- Vacuum-proof axial expansion joint consisting of a stainless steel bellows and threaded connection parts
- Connection parts with hexagon insert bit and male thread
- Multiple convolution bellows in various stainless steel grades
- Single ply structure

Material grade*	Material No. as per DIN EN	Temperature**	Possible uses
Stainless steel	1.4541	-196 °C up to +550 °C	Low temperature, acids, lyes, gases, fertilizers
	1.4404 1.4571	+550 °C	Media containing chloride, oil, soap, drinking water, food stuff, petrol

* Check or inquire about the resistance of material grades to temperature and medium.

** Check or inquire about reduction in pressure by temperature.

VERSIONS / THREADED CONNECTION PARTS

- Male thread

	Standard	Others
Dimensions	R 1/2" - R 2" ISO 7-1 (DIN 2999)	on request
Materials	1.4541	stainless steel etc.

PRESSURE RATE STANDARD PROGRAM PN 16

DN	BL	D _{ax tot} **	C _{ax}	A*	Ø D _a	Ø D ₁	L	SW	Weight
	mm	mm	N/mm	Effective bellows cross sectional area cm ²	Bellows outer Ø	Male thread Ø	Length of thread	Width across	approx. kg
15	125	24	49	7	38	R 1/2"	13	32	0.2
20	130	24	49	7	38	R 3/4"	15	32	0.2
25	145	20	49	16	54	R 1"	17	46	0.5
32	185	20	49	16	54	R 1 1/4"	19	-	0.5
40	200	26	67	25	66	R 1 1/2"	19	-	0.8
50	225	34	87	35	79	R 2"	24	-	1.2

Table values refer to +20 °C, bellows material 1.4541, 1000 cycles. Max. allowable pressure pulsation of 1.6 bar (brief periods). Please inquire for deviating values.

*Effective bellows cross sectional area is a theoretical value.

**This value represents the total possible movement. Example: Δ a_{xtot}= 28mm. This means that the expansion joint has a total movement value of 28 mm (= +/- 14 mm).

NOTE

Please comply with the general technical instructions regarding reaction force, moving force, fixed point load, installation instructions, etc.

Subject to technical alterations and deviations resulting from the manufacturing process.

APPLICATIONS

- for compensating axial movement
- for reducing tension, in pipes and their system components, e.g.
 - pumps
 - compressors
 - engines
 - turbines
 - machines
- to compensate for installation inaccuracies
- for installation in
 - heating installations
 - drinking water systems
- for pipe systems of stainless or unalloyed steel
- for copper or plastic pipes
- for pressfitting systems

CERTIFICATES

- CE (PED 2014/68/EU)

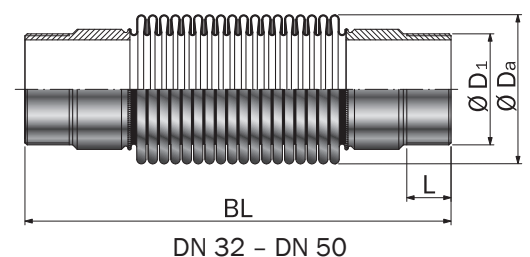
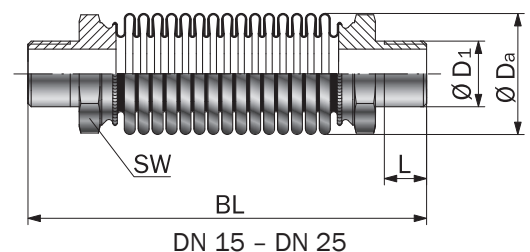

Type SG-10

STEEL EXPANSION JOINT TYPE SG-11

AXIAL EXPANSION JOINT DN 15 – 50 FEMALE THREAD

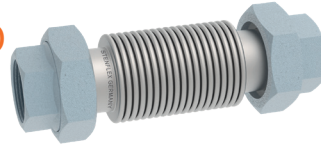

STRUCTURE TYPE SG-11 / STEEL BELLOWS PN 16

- Vacuum-proof axial expansion joint consisting of a stainless steel bellows and threaded connection parts
- Bellows with flared ends, connection parts with union nut and flat packing
- Connection parts with female thread
- Multiple convolution bellows in various stainless steel grades
- Single ply structure

Material grade*	Material No. as per DIN EN	Temperature**	Possible uses
Stainless steel	1.4541	-196 °C up to +550 °C	Low temperature, acids, lyes, gases, fertilizers
	1.4404 1.4571	+550 °C	Media containing chloride, oil, soap, drinking water, food stuff, petrol

* Check or inquire about the resistance of material grades to temperature and medium.

** Check or inquire about reduction in pressure by temperature.

VERSIONS / THREADED CONNECTION PARTS

- Female thread
- Union nut with female thread acc. ISO 228-1

	Standard
Dimensions	Female thread Rp 1/2" - Rp 2" acc. ISO 7-1 (DIN 2999)
Materials	GJMW-400-5 (malleable casting)
Corrosion protection	electrogalvanized

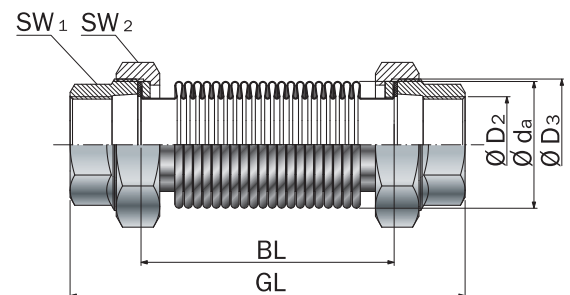

Type SG-11

PRESSURE RATE STANDARD PROGRAM PN 16

DN	BL	GL	D _{ax tot} **	C _{ax}	A* Effective bellows cross sectional area	Ø D _a	Ø D ₂	Ø D ₃	SW ₁	SW ₂	Weight
	mm	mm	Axial movement mm	Axial spring rate N/mm	cm ²	Bellows outer ø mm	Female thread ø inch	Union nut ø inch	Width across mm	Width across mm	approx. kg
15	130	185	24	28	5	36	Rp 1/2"	G 1"	25	38	0.5
20	135	190	24	30	7	36	Rp 3/4"	G 1 1/4"	31	47	0.8
25	150	212	26	49	16	54	Rp 1"	G 1 1/2"	38	53	0.9
32	158	224	30	111	25	66	Rp 1 1/4"	G 2"	48	66	1.3
40	154	226	30	111	25	66	Rp 1 1/2"	G 2 1/4"	53	73	1.7
50	161	245	36	177	35	79	Rp 2"	G 2 3/4"	66	90	2.6

Table values refer to +20 °C, bellows material 1.4541, 1000 cycles. Max. allowable pressure pulsation of 1.6 bar (brief periods). Please inquire for deviating values. *Effective bellows cross sectional area is a theoretical value. **This value represents the total possible movement. Example: $\Delta x_{tot} = 28$ mm. This means that the expansion joint has a total movement value of 28 mm (= +/- 14 mm). www.stenflex.com / info@stenflex.com

NOTE

Please comply with the general technical instructions regarding reaction force, moving force, fixed point load, installation instructions, etc.

Subject to technical alterations and deviations resulting from the manufacturing process.

APPLICATIONS

- for compensating axial movement
- for reducing tension, in pipes and their system components, e.g.
 - pumps
 - compressors
 - engines
 - turbines
 - machines
- to compensate for installation inaccuracies
- for installation in
 - exhaust systems
 - heating installations
- gas supply lines

CERTIFICATES

- CE (PED 2014/68/EU)
- DVGW (DN 25 -DN 50)

STEEL EXPANSION JOINT TYPE SF-20

LATERAL EXPANSION JOINT DN 32 – DN 500

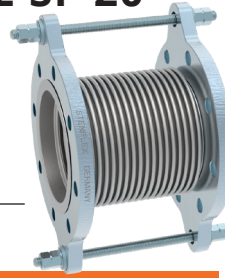

STRUCTURE TYPE SF-20 / STEEL BELLOWS PN 10, 16

- Vacuum-proof, short-length lateral expansion joint, consisting of a stainless steel bellows and rotatable flanges
- Rotatable flanges with tie rods to absorb reaction force
- Multiple convolution bellows in various stainless steel grades
- Single ply or multi-ply structure

Material grade*	Material No. as per DIN EN	Temperature**	Possible uses
Stainless steel	1.4541	-196 °C up to +550 °C	Low temperature, acids, lyes, gases, fertilizers
	1.4404 1.4571	+550 °C	Media containing chloride, oil, soap, drinking water, food stuff, petrol
Heat-resistant steel	1.4828	+900 °C	Hot gases, steam, air
	1.4878	+800 °C	

* Check or inquire about the resistance of material grades to temperature and medium.

** Check or inquire about reduction in pressure by temperature.

FLANGES / VERSIONS

- Rotatable flanges
- Flange drilling for through bolts

	Standard		Others
Dimensions	DN 32 – DN 500 acc. EN 1092-1 PN 10/16		ANSI, BS etc. Connection dimensions see technical annex page 213 – 215
Materials	1.0038 (S235JR), 1.4541		stainless steel etc.
Corrosion protection	DN 32 – DN 250 electro-galvanized	DN 300 – DN 500 anti-corrosion primed	hot-dip galvanized, special varnish, special coating etc.

NOTE

Please comply with the general technical instructions regarding reaction force, moving force, fixed point load, installation instructions, etc.

Subject to technical alterations and deviations resulting from the manufacturing process.

APPLICATIONS

- for compensating lateral movement
- for reducing tension, in pipes and their system components, e.g.
 - pumps
 - engines
 - machines
- for installation in
 - industrial applications
 - gas and water supply
 - exhaust systems
 - heating installations
 - drinking water systems
- to compensate for installation inaccuracies

TIE ROD RESTRAINTS

- External restraints carried on spherical washers/conical seats

Materials

Standard: tie rods 8.8

Others: stainless steel

Corrosion protection

Standard: electrogalvanized

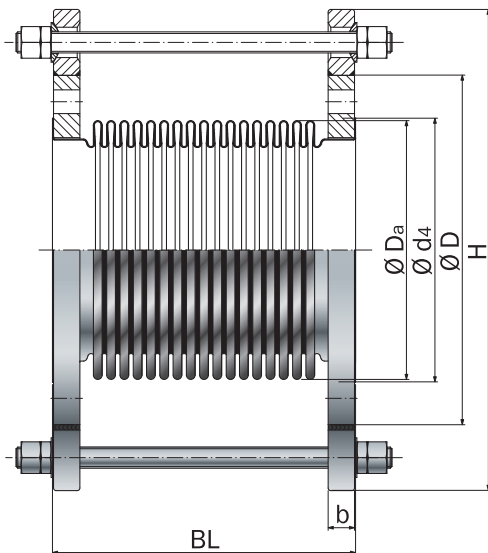
**Type SF-20**

External restraints, carried on spherical washers/conical seats (ball joint)

SPECIAL DESIGN

Other sizes (DN), lengths or pressure ratings on request.

CERTIFICATES

- CE (PED 2014/68/EU)
- American Bureau of Shipping
- Bureau Veritas
- DVGW (DN 32 – DN 200)
- DNV GL® / DNV®
- RINA

ACCESSORIES

- Internal guide sleeve
- Protective tube
- Gas sealings for DVGW-application

PRESSURE RATE STANDARD PROGRAM PN 10

DN	BL	$\Delta \text{lat}_{\text{tot}}$ Lateral movement	C_{lat} Lateral spring rate	F_{fric} Friction force restraints	$\varnothing d_4$ Flared end \varnothing mm	$\varnothing D_a$ Bellows outer \varnothing mm	PN Flange connection	$\varnothing D$ Flange outer \varnothing mm	H Flange height	b Flange thickness	Weight approx. kg
	mm	mm	N/mm	N/bar	mm	mm	EN1092	mm	mm	mm	kg
32	135	14	28	4	54	54	16	140	226	16	5.0
40	135	16	74	6	68	66	16	150	236	16	5.5
50	155	16	114	8	75	79	16	165	251	18	7.1
65	165	18	177	11	95	96	16	185	271	18	8.6
80	175	18	174	15	110	115	16	200	286	20	10.2
100	180	16	266	21	140	137	16	220	306	20	11.5
125	200	14	156	37	165	168	16	250	353	22	16.3
150	230	14	313	46	200	197	16	285	388	22	19.3
200	230	9	715	93	254	253	10	340	457	24	27.0
250	245	8	2571	130	310	302	10	395	512	26	33.9
300	295	10	1152	175	364	387	10	445	570	26	48.0
350	305	9	1493	202	396	419	10	505	630	30	65.0
400	310	8	2171	255	452	470	10	565	690	32	78.0
450	315	7	3034	440	498	521	10	615	793	36	108.0
500	320	6	4074	528	548	571	10	670	848	38	123.0

PRESSURE RATE STANDARD PROGRAM PN 16

DN	BL	$\Delta \text{lat}_{\text{tot}}$ Lateral movement	C_{lat} Lateral spring rate	F_{fric} Friction force restraints	$\varnothing d_4$ Flared end \varnothing mm	$\varnothing D_a$ Bellows outer \varnothing mm	PN Flange connection	$\varnothing D$ Flange outer \varnothing mm	H Flange height	b Flange thickness	Weight approx. kg
	mm	mm	N/mm	N/bar	mm	mm	EN1092	mm	mm	mm	kg
32	135	14	28	4	54	54	16	140	226	16	5.0
40	135	16	74	6	68	66	16	150	236	16	5.5
50	155	16	114	8	75	78	16	165	251	18	7.1
65	165	18	177	11	95	96	16	185	271	18	8.6
80	175	18	174	15	110	115	16	200	286	20	10.2
100	180	16	266	21	140	137	16	220	306	20	11.5
125	200	14	156	37	165	168	16	250	353	22	16.3
150	230	14	313	46	200	197	16	285	388	22	19.3
200	230	9	715	93	254	253	16	340	457	26	28.1
250	245	8	2571	130	310	302	16	405	570	29	47.0
300	320	8	2051	163	364	388	16	460	584	32	63.0
350	325	7	2671	191	396	420	16	520	644	35	82.0
400	330	6	3896	242	452	471	16	580	704	38	105.0
450	340	5	5446	415	498	522	16	640	820	42	144.0
500	345	5	7317	499	548	572	16	715	893	46	193.0

Table values refer to +20 °C, bellows material 1.4541, 1000 cycles. Max. allowable pressure pulsation of 1.0 bar (brief periods).
Please inquire for deviating values.

STEEL EXPANSION JOINT TYPE SF-21

LATERAL EXPANSION JOINT DN 32 – DN 500

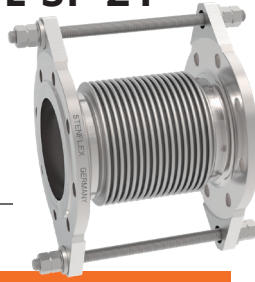

STRUCTURE TYPE SF-21 / STEEL BELLOWS PN 16

- Vacuum-proof lateral expansion joint consisting of a stainless steel bellows and welded flanges
- Flanges with tie rods to absorb reaction force
- Multiple convolution bellows in various stainless steel grades
- Single ply or multi-ply structure

Material grade*	Material No. as per DIN EN	Temperature**	Possible uses
Stainless steel	1.4541	-196 °C up to +550 °C	Low temperature, acids, lyes, gases, fertilizers
	1.4404 1.4571	+550 °C	Media containing chloride, oil, soap, drinking water, food stuff, petrol

* Check or inquire about the resistance of material grades to temperature and medium.

** Check or inquire about reduction in pressure by temperature.

FLANGES / VERSIONS

- Welded flanges with turned seal
- Flange drilling for through bolts

	Standard	Others
Dimensions	DN 32 – DN 500 acc. EN 1092-1 PN 10/16	ANSI, BS etc. Connection dimensions see technical annex page 213 – 215
Materials	1.0038 (S235JR) 1.0460 (P250GH)	stainless steel etc.
Corrosion protection	anti-corrosion primed	special varnish etc.

NOTE

Please comply with the general technical instructions regarding reaction force, moving force, fixed point load, installation instructions, etc.

Subject to technical alterations and deviations resulting from the manufacturing process.

APPLICATIONS

- for compensating lateral movement
- for reducing tension, in pipes and their system components, e.g.
 - pumps
 - compressors
 - engines
 - turbines
 - machines
 - process plants
- for installation in
 - industrial applications
 - gas and water supply
 - exhaust systems
 - heating installations
- to compensate for installation inaccuracies

TIE ROD RESTRAINTS

- External restraints carried on spherical washers/conical seats

Materials

Standard: tie rods 8.8

Others: stainless steel

Corrosion protection

Standard: electrogalvanized

SPECIAL DESIGN

Other sizes (DN), lengths or pressure ratings on request.

CERTIFICATES

- CE (PED 2014/68/EU)
- American Bureau of Shipping
- Bureau Veritas
- DVGW (DN 32 – DN 200)
- RINA

ACCESSORIES

- Internal guide sleeve
- Protective tube
- Gas sealings for DVGW-application

PRESSURE RATE STANDARD PROGRAM PN 16

DN	BL	$\Delta \text{lat}_{\text{tot}}$ Lateral movement	C_{lat} Lateral spring rate	F_{fric} Friction force restraints	$\varnothing D_a$ Bellows outer \varnothing mm	PN Flange connection	$\varnothing D$ Flange outer \varnothing mm	H Flange height	b Flange thickness	Weight approx. kg
	mm	mm	N/mm	N/bar		EN1092	mm	mm	mm	
32	150	8	28	4	54	16	140	220	18	4.9
40	175	10	125	5	66	16	150	230	18	5.4
50	205	14	157	6	79	16	165	245	18	6.5
65	210	14	237	9	96	16	185	265	18	7.6
80	225	13	278	12	115	16	200	280	20	9.7
100	235	14	302	18	137	16	220	300	20	10.9
125	265	14	156	35	168	16	250	370	22	19.0
150	290	14	313	45	197	16	285	405	22	22.6
200	310	9	761	73	253	16	340	460	24	33.0
250	335	8	2571	101	302	16	405	525	26	44.2
300	410	12	1145	131	386	16	460	584	28	71.0
350	415	11	1368	155	420	16	520	644	30	94.0
400	420	10	1995	197	471	16	580	704	32	118.0
450	420	9	2788	350	522	16	640	818	34	153.0
500	420	8	3746	425	572	16	715	893	36	193.0

Table values refer to +20 °C, bellows material 1.4541, 1000 cycles. Max. allowable pressure pulsation of 1.6 bar (brief periods). Please inquire for deviating values.

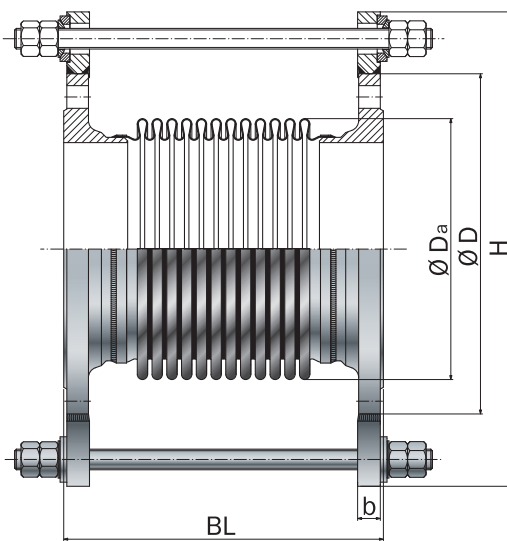
**Type SF-21**

External restraints, carried on spherical washers/conical seats (ball joint)

CUSTOMIZED PRODUCTION

STEEL EXPANSION JOINT TYPE SF-23

LATERAL EXPANSION JOINT



STRUCTURE TYPE SF-23 / STEEL BELLOWS PN 1, PN 6

- Vacuum-proof lateral expansion joint consisting of two stainless steel bellows with connecting pipe and rotatable flanges
- Suitable for simultaneous movements
- Long connecting pipes allow large lateral movements
- Multiple convolution bellows in various stainless steel grades
- Single ply or multi-ply structure
- DN 50 – DN 500 with flared ends
- DN 600 – DN 1000 with pre-welded flared ends

Material grade*	Material No. as per DIN EN	Temperature**	Possible uses
Stainless steel	1.4541	-196 °C up to +550 °C	Low temperature, acids, lyes, gases, fertilizers
	1.4404 1.4571	+550 °C	Media containing chloride, oil, soap, drinking water, food stuff, petrol

* Check or inquire about the resistance of material grades to temperature and medium.

** Check or inquire about reduction in pressure by temperature.

FLANGES / VERSIONS

- Rotable flanges
- Flange drilling for through bolts

	Standard		Others
Dimensions	DN 50 – DN 1000 acc. EN 1092-1 PN 6		ANSI, BS etc. Connection dimensions see technical annex page 213 – 215
Materials	1.0038 (S235JR)		stainless steel etc.
Corrosion protection	DN 50 – DN 250 electro-galvanized	DN 300 – DN 1000 anti-corrosion primed	hot-dip galvanized, special varnish, special coating etc.

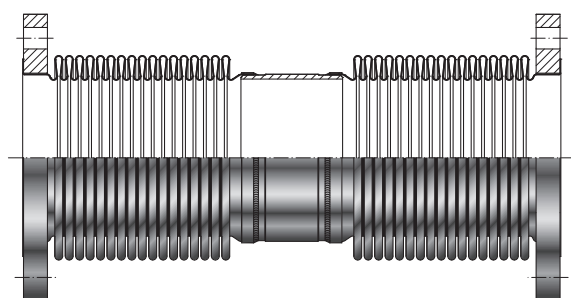

Type SF-23

NOTE

Please comply with the general technical instructions regarding reaction force, moving force, fixed point load, installation instructions, etc.

Subject to technical alterations and deviations resulting from the manufacturing process.

APPLICATIONS

- for compensating simultaneous axial and lateral movement
- for reducing tension, in pipes and their system components, e.g.
 - pumps
 - compressors
 - engines
 - turbines
 - machines
 - process plants
- for installation in
 - long pipe routings
 - industrial application
 - exhaust systems
 - heating installations
- to compensate for installation inaccuracies

CONNECTING PIPE / GUIDE SLEEVE

Materials

Standard: 1.0345 (P235GH)
1.0038 (S235JR)

Others: stainless steel etc.

Corrosion protection

Standard: anti-corrosion primed

Others: special varnish etc.

SPECIAL DESIGN

Other sizes (DN), lengths or pressure ratings on request.

CERTIFICATES

- CE (PED 2014/68/EU)
- American Bureau of Shipping
- Bureau Veritas
- RINA

CUSTOMIZED PRODUCTION

STEEL EXPANSION JOINT TYPE SF-24

LATERAL EXPANSION JOINT MOVABLE IN ONE PLANE

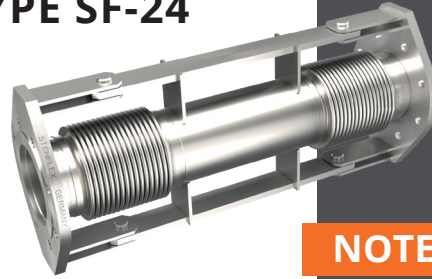

STRUCTURE TYPE SF-24 / STEEL BELLOWS PN 6, PN 10

- Vacuum-proof lateral expansion joint consisting of two stainless steel bellows with connecting pipe, pipe ends and welded flanges
- Double hinge restraints to absorb reaction force
- Long connecting pipes allow large lateral movements
- Multiple convolution bellows in various stainless steel grades
- Single ply or multi-ply structure

Material grade*	Material No. as per DIN EN	Temperature**	Possible uses
Stainless steel	1.4541	-196 °C up to +550 °C	Low temperature, acids, lyes, gases, fertilizers
	1.4404 1.4571	+550 °C	Media containing chloride, oil, soap, drinking water, food stuff, petrol

* Check or inquire about the resistance of material grades to temperature and medium.

** Check or inquire about reduction in pressure by temperature.

FLANGES / VERSIONS

- Welded flanges
- Flange drilling for through bolts

	Standard	Others
Dimensions	DN 32 – DN 150 / PN 16 DN 200 – DN 500 / PN 10 acc. EN 1092-1	ANSI, BS etc. Connection dimensions see technical annex page 213 – 215
Materials	1.0038 (S235JR)	stainless steel etc.
Corrosion protection	anti-corrosion primed	special varnish etc.

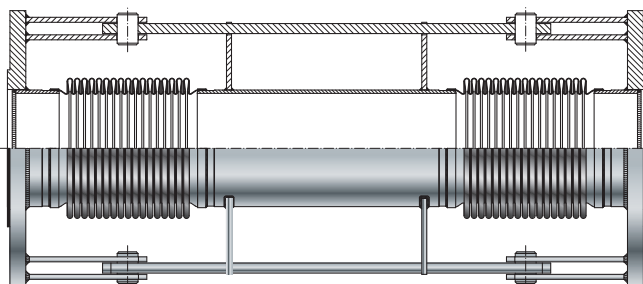

Type SF-24

NOTE

Please comply with the general technical instructions regarding reaction force, moving force, fixed point load, installation instructions, etc.

Subject to technical alterations and deviations resulting from the manufacturing process.

APPLICATIONS

- for compensating large lateral movement
- for reducing tension
- for installation in
 - industrial applications
 - pipe line and plant construction

HINGE RESTRAINTS

- Pivot of joint bars at bellow's center
- Joint bars control bellow's movement

Materials

Standard: 1.0038 (S235JR)

Others: stainless steel, etc.

Corrosion protection

Standard: anti-corrosion primed

Others: special varnish, etc.

CONNECTING PIPE / GUIDE SLEEVE

Materials

Standard: 1.0345 (P235GH)

1.0038 (S235JR)

Others: stainless steel etc.

Corrosion protection

Standard: anti-corrosion primed

Others: special varnish etc.

SPECIAL DESIGN

Other sizes (DN), lengths or pressure ratings on request.

CERTIFICATES

- CE (PED 2014/68/EU)

CUSTOMIZED PRODUCTION

STEEL EXPANSION JOINT TYPE SF-25

LATERAL-EXPANSION JOINT MOVABLE IN ALL PLANES

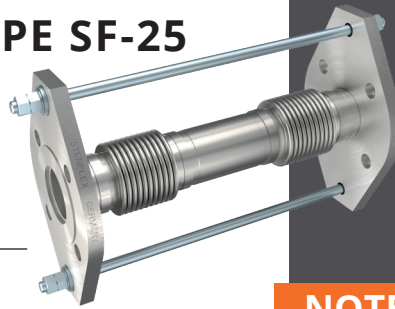

STRUCTURE TYPE SF-25 / STEEL BELLOWS PN 10

- Vacuum-proof lateral expansion joint consisting of two stainless steel bellows with connecting pipe, pipe ends and welded flanges
- Tie rods to absorb reaction force
- Long connecting pipes allow large movements
- Multiple convolution bellows in various stainless steel grades
- Single ply or multi-ply structure

Material grade*	Material No. as per DIN EN	Temperature**	Possible uses
Stainless steel	1.4541	-196 °C up to +550 °C	Low temperature, acids, lyes, gases, fertilizers
	1.4404 1.4571	+550 °C	Media containing chloride, oil, soap, drinking water, food stuff, petrol

* Check or inquire about the resistance of material grades to temperature and medium.

** Check or inquire about reduction in pressure by temperature.

FLANGES / VERSIONS

- Welded flanges
- Flange drilling for through bolts

	Standard	Others
Dimensions	DN 32 – DN 150 / PN 16 DN 200 – DN 500 / PN 10 acc. EN 1092-1	ANSI, BS etc. Connection dimensions see technical annex page 213 – 215
Materials	1.0038 (S235JR)	stainless steel etc.
Corrosion protection	anti-corrosion primed	special varnish etc.

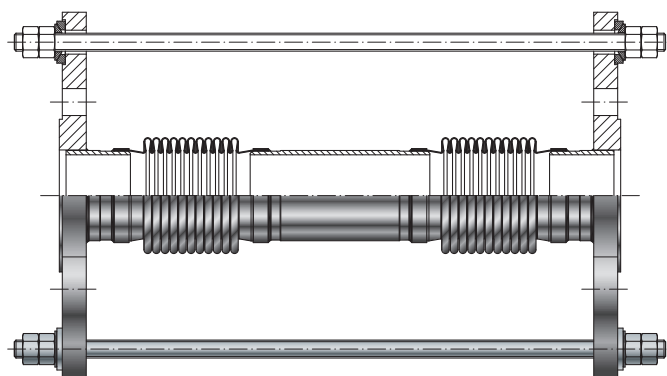

Type SF-25

NOTE

Please comply with the general technical instructions regarding reaction force, moving force, fixed point load, installation instructions, etc.

Subject to technical alterations and deviations resulting from the manufacturing process.

APPLICATIONS

- for compensating large lateral movement
- for 3D movement absorption in pipe systems
- for reducing tension
- for installation in
 - industrial applications
 - pipe line and plant construction

TIE ROD RESTRAINTS

- External restraints, carried on spherical washers and conical seats

Materials

Standard: tie rods 8.8

Others: stainless steel, etc.

Corrosion protection

Standard: electrogalvanized

CONNECTING PIPE / GUIDE SLEEVE

Materials

Standard: 1.0345 (P235GH)

1.0038 (S235JR)

Others: stainless steel etc.

Corrosion protection

Standard: anti-corrosion primed

Others: special varnish etc.

SPECIAL DESIGN

Other sizes (DN), lengths or pressure ratings on request.

CERTIFICATES

- CE (PED 2014/68/EU)

CUSTOMIZED PRODUCTION

STEEL EXPANSION JOINT TYPE SA-20

LATERAL-EXPANSION JOINT

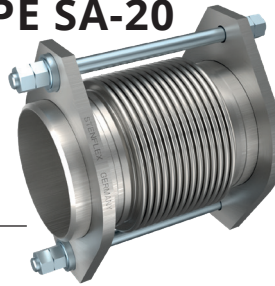

NOTE

Please comply with the general technical instructions regarding reaction force, moving force, fixed point load, installation instructions, etc.

Subject to technical alterations and deviations resulting from the manufacturing process.

STRUCTURE TYPE SA-20 / STEEL BELLOWS PN 16

- Vacuum-proof lateral expansion joint consisting of a stainless steel bellows and welded pipe ends (welding ends)
- Welded joint bars with tie rod restraints to absorb reaction force
- Multiple convolution bellows in various stainless steel grades
- Single ply or multi-ply structure

Material grade*	Material No. as per DIN EN	Temperature**	Possible uses
Stainless steel	1.4541	-196 °C up to +550 °C	Low temperature, acids, lyes, gases, fertilizers
	1.4404 1.4571	+550 °C	Media containing chloride, oil, soap, drinking water, food stuff, petrol

* Check or inquire about the resistance of material grades to temperature and medium.

** Check or inquire about reduction in pressure by temperature.

APPLICATIONS

- for compensating lateral movement
- for reducing tension, in pipes and their system components, e.g.
 - compressors
 - engines
 - turbines
 - machines
 - process plants
- for installation in
 - industrial applications
 - exhaust systems
 - heating installations
 - gas supply lines

TIE ROD RESTRAINTS

- External restraints carried on spherical washers/conical seats

Materials

Standard: tie rods 8.8

Others: stainless steel

Corrosion protection

Standard: electrogalvanized

SPECIAL DESIGN

Other sizes (DN), lengths or pressure ratings on request.

CERTIFICATES

- CE (PED 2014/68/EU)
- American Bureau of Shipping
- Bureau Veritas
- DVGW (DN 32 – DN 200)
- RINA

ACCESSORIES

- Internal guide sleeve
- Protective tube

WELDING ENDS / VERSIONS

- Welded pipe ends

	Standard	Others
Dimensions	on request	
Materials	1.0345 (P235GH) 1.0038 (S235JR)	stainless steel etc.
Corrosion protection	anti-corrosion primed	special varnish etc.

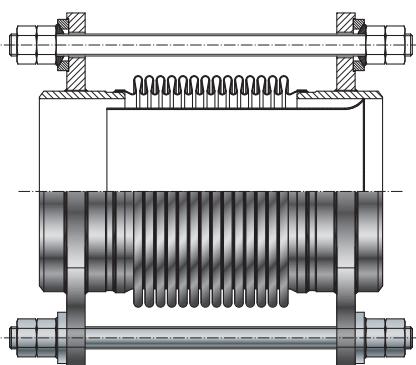

Type SA-20 with inner guide sleeve
External restraints, carried on spherical washers/conical seats (ball joint)

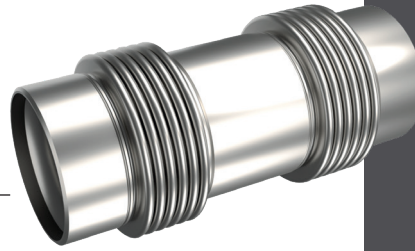
CUSTOMIZED PRODUCTION**STEEL EXPANSION JOINT TYPE SA-23****LATERAL
EXPANSION JOINT****STRUCTURE TYPE SA-23 / STEEL BELLOWS PN 1, PN 6**

- Vacuum-proof lateral expansion joint consisting of two stainless steel bellows with connecting pipe and welded pipe ends (welding ends)
- Suitable for simultaneous movements
- Long connecting pipes allow large lateral movements
- Multiple convolution bellows in various stainless steel grades
- Single ply or multi-ply structure

Material grade*	Material No. as per DIN EN	Temperature**	Possible uses
Stainless steel	1.4541	-196 °C up to +550 °C	Low temperature, acids, lyes, gases, fertilizers
	1.4404 1.4571	+550 °C	Media containing chloride, oil, soap, drinking water, food stuff, petrol

* Check or inquire about the resistance of material grades to temperature and medium.

** Check or inquire about reduction in pressure by temperature.

WELDING ENDS / CONNECTING PIPE / VERSIONS

- Welded pipe ends and connecting pipe

	Standard	Others
Dimensions	see table of type SA13	on request
Materials	1.0345 (P235GH) 1.0038 (S235JR)	stainless steel etc.
Corrosion protection	anti-corrosion primed	special varnish etc.

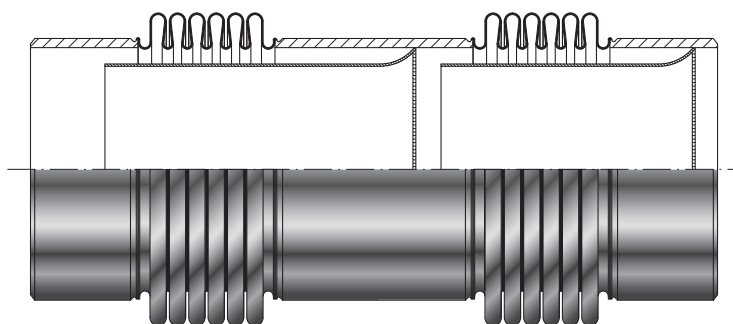

Type SA-23 with inner guide sleeve

NOTE

Please comply with the general technical instructions regarding reaction force, moving force, fixed point load, installation instructions, etc.

Subject to technical alterations and deviations resulting from the manufacturing process.

APPLICATIONS

- for compensating simultaneous axial and lateral movement
- for reducing tension, in pipes and their system components, e.g.
 - compressors
 - engines
 - turbines
 - machines
 - process plants
- for installation in
 - long pipe routings
 - industrial applications
 - exhaust systems
 - heating installations
- to compensate for installation inaccuracies

SPECIAL DESIGN

Other sizes (DN), lengths or pressure ratings on request.

CERTIFICATES

- CE (PED 2014/68/EU)
- American Bureau of Shipping
- Bureau Veritas
- RINA
-

ACCESSORIES

- Internal guide sleeve
- Protective tube

CUSTOMIZED PRODUCTION

STEEL EXPANSION JOINT TYPE SA-24

LATERAL EXPANSION JOINT MOVABLE IN ONE PLANE

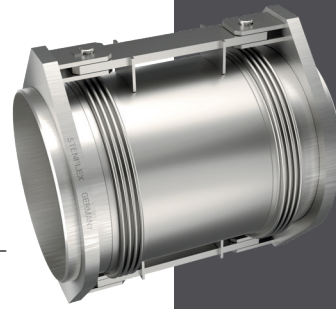
STRUCTURE TYPE SA-24 / STEEL BELLOWS PN 6, 10

- Vacuum-proof lateral expansion joint consisting of two stainless steel bellows with connecting pipe and welded pipe ends (welding ends)
- Welded joint bars with double hinge restraints to absorb reaction force
- Long connecting pipes allow large lateral movements
- Multiple convolution bellows in various stainless steel grades
- Single ply or multi-ply structure

Material grade*	Material No. as per DIN EN	Temperature**	Possible uses
Stainless steel	1.4541	-196 °C up to +550 °C	Low temperature, acids, lyes, gases, fertilizers
	1.4404 1.4571	+550 °C	Media containing chloride, oil, soap, drinking water, food stuff, petrol

* Check or inquire about the resistance of material grades to temperature and medium.

** Check or inquire about reduction in pressure by temperature.

WELDING ENDS / CONNECTING PIPE / VERSIONS

Welded pipe ends and connecting pipe

	Standard	Others
Dimensions	on request	
Materials	1.0345 (P235GH) 1.0038 (S235JR)	stainless steel etc.
Corrosion protection	anti-corrosion primed	special varnish etc.

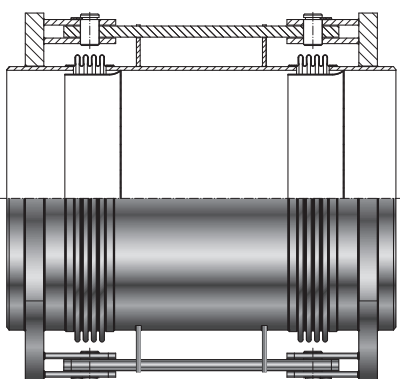

Type SA-24 with inner guide sleeve

NOTE

Please comply with the general technical instructions regarding reaction force, moving force, fixed point load, installation instructions, etc.

Subject to technical alterations and deviations resulting from the manufacturing process.

APPLICATIONS

- for compensating large lateral movement
- for reducing tension
- for installation in
 - industrial applications
 - pipe line and plant construction

HINGE RESTRAINTS

- Pivot of joint bars at center of bellows
- Joint bars control bellows movement

Materials

Standard: 1.0038 (S235JR)

Others: stainless steel, etc.

Corrosion protection

Standard: anti-corrosion primed

Others: special varnish, etc.

SPECIAL DESIGN

Other sizes (DN), lengths or pressure ratings on request.

CERTIFICATES

- CE (PED 2014/68/EU)

ACCESSORIES

- Internal guide sleeve
- Protective tube

CUSTOMIZED PRODUCTION

STEEL EXPANSION JOINT TYPE SA-25

LATERAL EXPANSION JOINT MOVABLE IN ALL PLANES

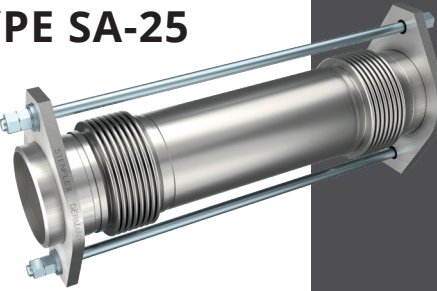

STRUCTURE TYPE SA-25 / STEEL BELLOWS PN 6, 10

- Vacuum-proof lateral expansion joint consisting of two stainless steel bellows with connecting pipe and welded pipe ends (welding ends)
- Welded joint bars with tie rods to absorb reaction force
- Long connecting pipes allow large lateral movements
- Multiple convolution bellows in various stainless steel grades
- Single ply or multi-ply structure

Material grade*	Material No. as per DIN EN	Temperature**	Possible uses
Stainless steel	1.4541	-196 °C up to +550 °C	Low temperature, acids, lyes, gases, fertilizers
	1.4404 1.4571	+550 °C	Media containing chloride, oil, soap, drinking water, food stuff, petrol

* Check or inquire about the resistance of material grades to temperature and medium.

** Check or inquire about reduction in pressure by temperature.

WELDING ENDS / CONNECTING PIPE / VERSIONS

- Welded pipe ends and connecting pipe

	Standard	Others
Dimensions	see table of type SA13	on request
Materials	1.0345 (P235GH) 1.0038 (S235JR)	stainless steel etc.
Corrosion protection	anti-corrosion primed	special varnish etc.

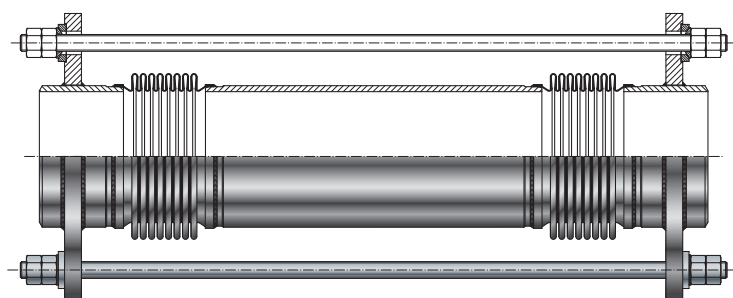

Type SA-25

NOTE

Please comply with the general technical instructions regarding reaction force, moving force, fixed point load, installation instructions, etc.

Subject to technical alterations and deviations resulting from the manufacturing process.

APPLICATIONS

- for compensating large lateral movement
- for 3D movement absorption in pipe systems
- for reducing tension
- for installation in
 - industrial applications
 - pipe line and plant construction

TIE ROD RESTRAINTS

- External restraints, carried on spherical washers and conical seats

Materials

Standard: tie rods 8.8

Others: stainless steel, etc.

Corrosion protection

Standard: electrogalvanized

SPECIAL DESIGN

Other sizes (DN), lengths or pressure ratings on request.

CERTIFICATES

- CE (PED 2014/68/EU)

CUSTOMIZED PRODUCTION

STEEL EXPANSION JOINT TYPE SF-32

ANGULAR EXPANSION JOINT MOVABLE IN ONE PLANE

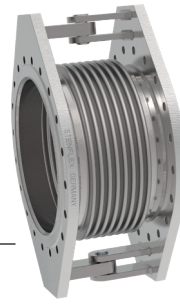

NOTE

Please comply with the general technical instructions regarding reaction force, moving force, fixed point load, installation instructions, etc.

Subject to technical alterations and deviations resulting from the manufacturing process.

STRUCTURE TYPE SF-32 / STEEL BELLOWS PN 6, 16

- Vacuum-proof angular expansion joint consisting of a stainless steel bellows with pipe ends and welded flanges
- Hinge restraints to absorb reaction force
- Multiple convolution bellows in various stainless steel grades
- Single ply or multi-ply structure

Material grade*	Material No. as per DIN EN	Temperature**	Possible uses
Stainless steel	1.4541	-196 °C up to +550 °C	Low temperature, acids, lyes, gases, fertilizers
	1.4404 1.4571	+550 °C	Media containing chloride, oil, soap, drinking water, food stuff, petrol

* Check or inquire about the resistance of material grades to temperature and medium.

** Check or inquire about reduction in pressure by temperature.

FLANGES / VERSIONS

- Welded flanges
- Flange drilling for through bolts

	Standard	Others
Dimensions	DN 50 – DN 1000 / PN 6 DN 50 – DN 250 / PN 16 acc. EN 1092-1	ANSI, BS etc. Connection dimensions see technical annex page 213 – 215
Materials	1.0038 (S235JR)	stainless steel etc.
Corrosion protection	anti-corrosion primed	special varnish etc.

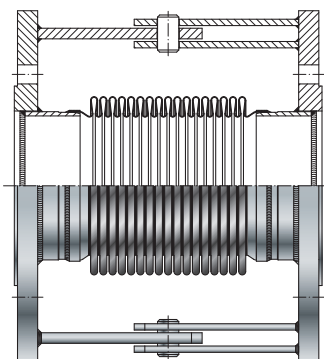

Type SF-32

APPLICATIONS

- for compensating angular movement in angular pipe routings
- as double or triple joint compensation system for large movements
- for reducing tension
- for installation in
 - industrial applications
 - pipe line and plant construction

HINGE RESTRAINTS

- Pivot of joint bars at center of bellows
- Hinge restraints control bellows movement

Materials

Standard: 1.0038 (S235JR)

Others: stainless steel, etc.

Corrosion protection

Standard: anti-corrosion primed

Others: special varnish, etc.

PIPE ENDS

Materials

Standard: 1.0305 (St 35.8),
1.0038 (S235JR)

Others: stainless steel, etc.

Corrosion protection

Standard: anti-corrosion primed

Others: special varnish, etc.

SPECIAL DESIGN

Other sizes (DN), lengths or pressure ratings on request.

CERTIFICATES

- CE (PED 2014/68/EU)

CUSTOMIZED PRODUCTION

STEEL EXPANSION JOINT TYPE SF-33

ANGULAR EXPANSION JOINT CARDANIC MOVABLE

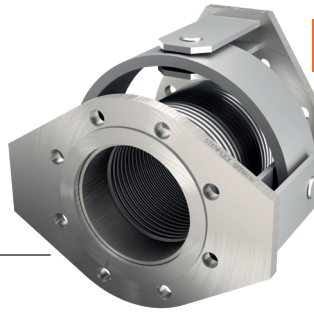
STRUCTURE TYPE SF-33 / STEEL BELLOWS PN 6, 16

- Vacuum-proof angular expansion joint consisting of a stainless steel bellows with pipe ends and welded flanges
- Welded cardan hinge restraints to absorb reaction force
- Multiple convolution bellows in various stainless steel grades
- Single ply or multi-ply structure

Material grade*	Material No. as per DIN EN	Temperature**	Possible uses
Stainless steel	1.4541	-196 °C up to +550 °C	Low temperature, acids, lyes, gases, fertilizers
	1.4404 1.4571	+550 °C	Media containing chloride, oil, soap, drinking water, food stuff, petrol

* Check or inquire about the resistance of material grades to temperature and medium.

** Check or inquire about reduction in pressure by temperature.

FLANGES / VERSIONS

- Welded flanges
- Flange drilling for through bolts

	Standard	Others
Dimensions	DN 50 – DN 1000 / PN 6 DN 50 – DN 250 / PN 16 acc. EN 1092-1	ANSI, BS etc. Connection dimensions see technical annex page 213 – 215
Materials	1.0038 (S235JR)	stainless steel etc.
Corrosion protection	anti-corrosion primed	special varnish etc.

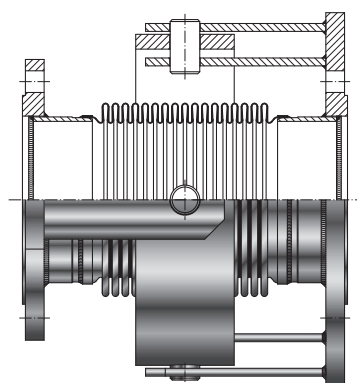

Type SF-33 with inner guide sleeve

NOTE

Please comply with the general technical instructions regarding reaction force, moving force, fixed point load, installation instructions, etc.

Subject to technical alterations and deviations resulting from the manufacturing process.

APPLICATIONS

- for compensating angular movement in angular and deflecting pipe routings
- as double or triple joint compensation system for large movements
- for reducing tension
- for installation in
 - industrial applications
 - pipe line and plant construction

CARDAN HINGE RESTRAINTS

- Pivot of joint bars at center of bellows
- Hinge restraints control bellows movement

Materials

Standard: 1.0038 (S235JR)

Others: stainless steel, etc.

Corrosion protection

Standard: anti-corrosion primed

Others: special varnish, etc.

PIPE ENDS
Materials

Standard: 1.0305 (St 35.8),

1.0038 (S235JR)

Others: stainless steel, etc.

Corrosion protection

Standard: anti-corrosion primed

Others: special varnish, etc.

SPECIAL DESIGN

Other sizes (DN), lengths or pressure ratings on request.

CERTIFICATES

- CE (PED 2014/68/EU)

CUSTOMIZED PRODUCTION

STEEL EXPANSION JOINT TYPE SA-33

ANGULAR EXPANSION JOINT CARDANIC MOVABLE

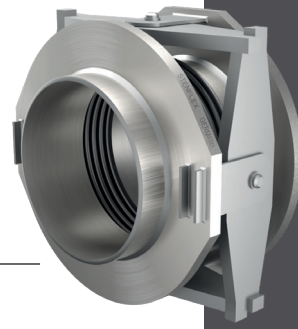

STRUCTURE TYPE SA-33 / STEEL BELLOWS PN 6, 16

- Vacuum-proof angular expansion joint consisting of a stainless steel bellows and welded pipe ends (welding ends)
- Welded joint bars with cardan hinge restraints to absorb reaction force
- Multiple convolution bellows in various stainless steel grades
- Single ply or multi-ply structure

Material grade*	Material No. as per DIN EN	Temperature**	Possible uses
Stainless steel	1.4541	-196 °C up to +550 °C	Low temperature, acids, lyes, gases, fertilizers
	1.4404 1.4571	+550 °C	Media containing chloride, oil, soap, drinking water, food stuff, petrol

* Check or inquire about the resistance of material grades to temperature and medium.

** Check or inquire about reduction in pressure by temperature.

WELDING ENDS / CONNECTING PIPE / VERSIONS

- Welded pipe ends

	Standard	Others
Dimensions	on request	
Materials	1.0345 (P235GH) 1.0038 (S235JR)	stainless steel
Corrosion protection	anti-corrosion primed	special varnish etc.

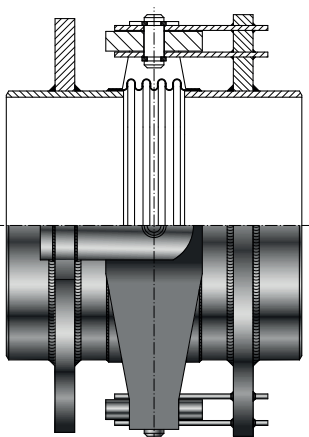

Type SA-33

NOTE

Please comply with the general technical instructions regarding reaction force, moving force, fixed point load, installation instructions, etc.

Subject to technical alterations and deviations resulting from the manufacturing process.

APPLICATIONS

- for compensating angular movement in angular and deflecting pipe routings
- as double or triple joint compensation system for large movements
- for reducing tension
- for installation in
 - industrial applications
 - pipe line and plant construction

HINGE RESTRAINTS

- Pivot of joint bars at center of bellows
- Hinge restraints control bellows movement

Materials

Standard: 1.0038 (S235JR)

Others: stainless steel, etc.

Corrosion protection

Standard: anti-corrosion primed

Others: special varnish, etc.

SPECIAL DESIGN

Other sizes (DN), lengths or pressure ratings on request.

CERTIFICATES

- CE (PED 2014/68/EU)

PTFE EXPANSION JOINTS PROGRAMME OVERVIEW

STENFLEX® **PTFE EXPANSION JOINTS** ARE PARTICULARLY SUITABLE FOR AGGRESSIVE MEDIA. VIRTUALLY FIRE-PROOF, PTFE IS UNIVERSALLY RESISTANT TO NEARLY ALL CHEMICALS AND SOLVENTS.

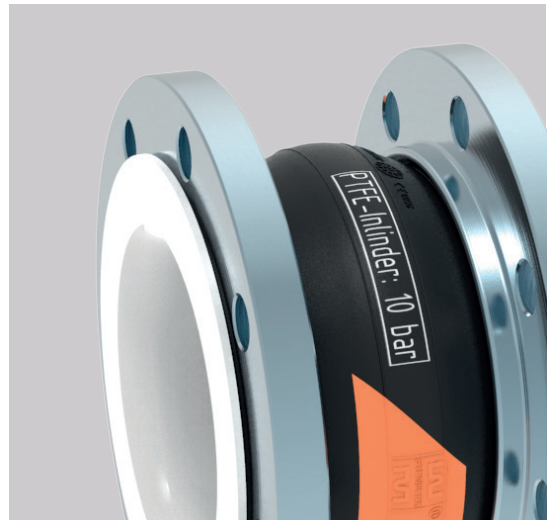

QUALITY.

PTFE EXPANSION JOINTS

GENERAL DESCRIPTION OF PTFE EXPANSION JOINTS

For 50 years STENFLEX® PTFE expansion joints have been manufactured from top quality materials. They have served with distinction throughout decades of practical use. Constant further development and innovations continuously update our product range to meet the demands of current and changing markets. The result: efficient and highly reliable products with superior durability.

DEVELOPMENT/DESIGN

STENFLEX® PTFE expansion joints are rated by calculation and optimized by experimentation. Our development engineers use the most up-to-date development tools to validate the design process in terms of form, function and installation – from the earliest stage of the development process. This ensures that we can provide efficient, highly dependable products with a long service life.

VERSIONS

STENFLEX® PTFE expansion joints vary with regard to the following criteria:

- type (universal and lateral expansion joint)
- structure of the bellows (rated to pressure and temperature load)
- flange connection

Our PTFE expansion joints are delivered ready for installation.

In addition to our standard versions featured in the catalogue, we also develop special versions that are produced to operate under special conditions.

Connecting parts (that deviate from DIN), such as ISO, ANSI, BS, VG, SAE-standards etc. can also be supplied.

APPLICATIONS

PTFE expansion joints have been developed for certain applications.

PTFE has a universal chemical resistance against almost all chemicals and solvents within its continuous operating temperature – with the exception of molten alkalis, elementary fluorine and certain halogenes.

They are used primarily in appliances, machinery, apparatus and pipe-systems

- to compensate for movement
- to compensate for expansion caused by differences in temperature
- to reduce tension
- to dampen oscillation, hinder vibration transmission, muffle noise/ sound
- as adapters to compensate for assembly or installation inaccuracies.

PTFE expansion joints are mainly used in the following industries:

- Chemical industry
- Process engineering
- Food product industry
- Beverage industry
- Pharmaceutical industry
- Treatment and disposal technology
- Information Technology

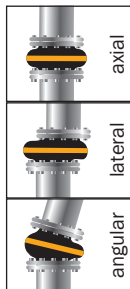
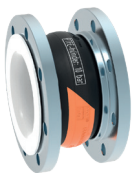

Universal PTFE expansion joints

Structure: Bellows with connection parts (rotatable flanges)

Movement absorption: The absorption of axial, lateral, angular and simultaneous movement is possible. Universal expansion joints with two bellows and a connecting pipe are used to absorb large movement.

Fixed points: Robust pipe fixed points and correct pipe-routing are essential when axial force must be absorbed.

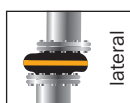

Lateral PTFE expansion joints

Structure: Bellows with flanges and laterally moving restraints

Movement absorption: Lateral shift of the expansion joint is possible. The restraint absorbs axial reaction force and relieves pressure on the pipe's fixed points. Lateral expansion joints with two bellows and a connecting pipe are used to absorb large movement.

Fixed points: Only light fixed points are needed to absorb lateral moving and friction force.

STRUCTURE

The STENFLEX® type Ai expansion joint consists of a single convolution molded bellows with synthetic fibre reinforcements. The bellows is equipped with a seamless PTFE lining and self-sealing flared ends.

MATERIAL QUALITIES

PTFE bellows are available in two material grades:

- Bellows of white PTFE
- Bellows of black PTFE

White PTFE bellows are not electrically conductive. Hence they also insulate. Black PTFE bellows incorporate added soot. They are electrically conductive. The impedance is: $<10^6$ Ohm (DIN IEC 93, VDE 0303-30).

The bellows are contour-molded by high density extrusion. The bellows are not mechanically machined from solid material.

The operating limits of the bellows (pressure load ability depending on temperature) must be observed when rating the expansion joints.

STENFLEX® PTFE bellows are made from top quality material grades to cover a range of operating conditions in many different areas.

PTFE is physiologically harmless within its thermal range of application.

Detailed documents regarding media resistance of PTFE bellows are available on request.

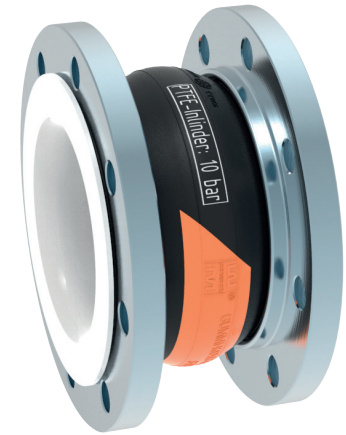

Type Ai-1
Rubber expansion joint with PTFE-lining

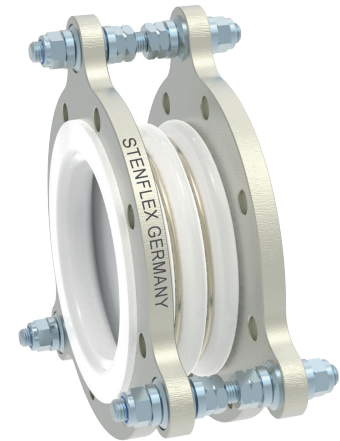

Type P-4
PTFE expansion joint

Material grade	PTFE Polytetrafluoroethylene
Trade names	Teflon, Hostaflon, Fluon, Polyfluoron
Properties	Heat-, and weather-proof material with outstanding chemical resistance to aggressive media. Excellent electrical insulating properties (white material). Temperature resistance in continuous operation from -50 °C to $+200$ °C.
Applications	Organic and inorganic acids, lyes, chloride, sulphate, solvents, bleaches, peroxide, fuels, mineral oil, hydraulic oil, halogens, gases

PTFE EXPANSION JOINTS

GENERAL DESCRIPTION OF PTFE EXPANSION JOINTS

CONNECTION PARTS

STENFLEX® PTFE expansion joints are supplied ready for installation. They are connected to pipes, fittings, pumps, tanks etc., by standard flanges.

The connections are standardized to fit commercially available pipes and flanges. See data sheets for details.

FLANGES

Flanges for PTFE expansion joints in the Ai-series have a special machined groove to accommodate the rubber rim and are mounted in a rotating position at the bellows. This makes it much easier to mount the pipeline.

The flanges have stabilizing collars on the side facing the bellows. This stabilizes the bellows and ensures compliance with safety spacing between the ends of the screws and the rubber bellows throughout the entire pressure and movement range. This eliminates the risk of damage to the rubber bellows possibly caused by the screwends.

STENFLEX® PTFE expansion joints in the P-series have rotatable flanges.

STENFLEX® lateral expansion joints with tie rod restraints, have been developed for high operating pressures or large-diameter pipes. The axial force produced by pipeline inner pressure is absorbed by the expansion joint restraints. They relieve the pressure on the fixed points of the pipeline.

Flanges for lateral expansion joints are equipped with ears for tie rod restraints. Depending on expansion joint type and size, they differ as follows:

- Flange with molded ears
- Oval flanges

Flanges made of unalloyed steels are electrogalvanized or given an anti-corrosion prime coating. Stainless steel is used to meet tougher corrosion protection requirements. Other materials and forms of corrosion protection (hot-dip galvanizing, special varnish, special coating etc.) are available on request.

Flange material	Material No. as per DIN EN	Designation as per DIN EN (DIN)
Unalloyed steel	1.0038	S235JR
Stainless steel	1.4541	X6CrNiTi18-10
	1.4571	X6CrNiMoTi17-12-2

NOTE

The permissible operating and testing pressure depends on the rating of the overall expansion joint taking account of all components:

- bellows
- flanges
- restraints

Standard flanges of the PTFE expansion joints are machined mechanically to the tolerated fit-sizes.

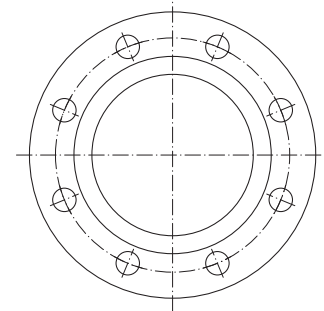

Standard flange with machined groove to accommodate rubber bellows and stabilizing collar (universal expansion joint)

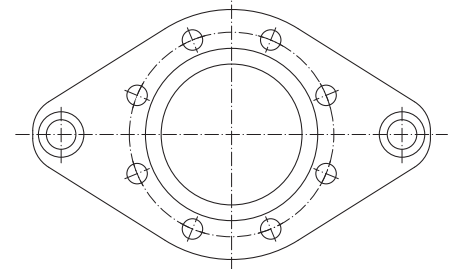

Oval flange with ears for the restraints (lateral expansion joint)

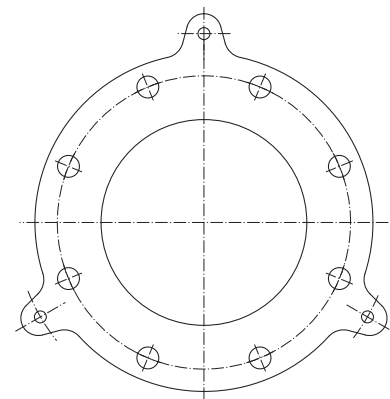

Flange with molded ears for the restraints (lateral expansion joint)

RESTRAINTS

Restraints are used for lateral expansion joints. The restraints absorb axial reaction force produced by internal pressure. Even so, the connected pipe must still be equipped with light fixed points to absorb the moving force. The precise rating and operating parameters of the corresponding machine or plant must be known for optimum calculation of the restraints. Standard restraints are available for the lateral expansion joint program. The restraints are calculated on the basis of material strength values at +20 °C. Reduced strength values are taken into consideration at higher temperatures.

TIE ROD RESTRAINTS

There are two types of tie rod restraints for lateral PTFE expansion joints

- External restraints: to absorb reaction force from internal pressure (e.g. type Ai-2, P2)
- External and internal restraints: to absorb reaction force from internal pressure and vacuum (type P-4).

The tie rods in the flange ears are flexibly carried

- on silencing rubber sockets up to DN 150
- on spherical washers and conical seats as from DN 175.

Standard tie rods, spherical washers and conical seats are electrogalvanized. Stainless steel can be used for restraint elements to meet higher corrosion protection requirements. Other anti-corrosion treatment – hot-dip galvanizing, special varnish, special coatings – are available on request.

Material tie rod restraint	Unalloyed steel		Stainless steel	
	Tie rods	Washers	Tie rods	Washers
Steel group / Strength class	5.6	5.6	A2-50	A4-50
	8.8	8.8	A2-70	A4-70
	9.8	9.8		

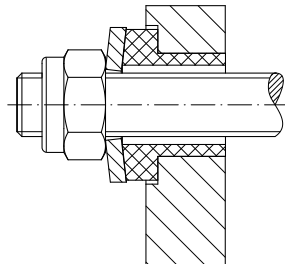

Sound-damping external restraint (lateral expansion joint)

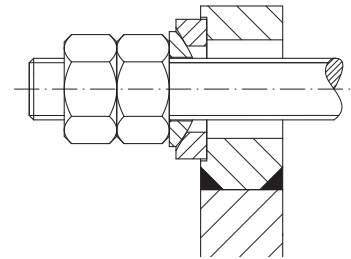

External restraint with spherical washer and conical seat (lateral expansion joint)

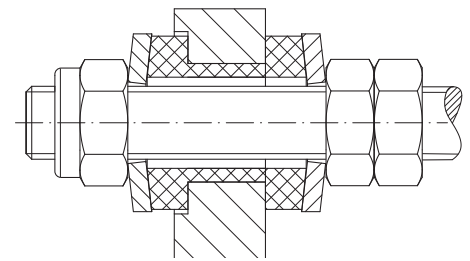

Sound-damping external and internal restraint (lateral expansion joint)

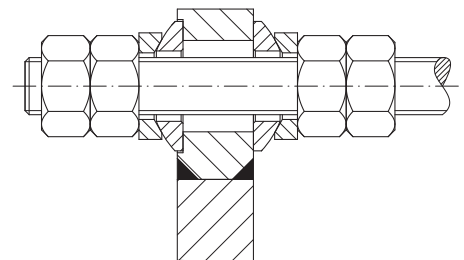

External and internal restraint with spherical washer and conical seat (lateral expansion joint)

PTFE EXPANSION JOINTS

GENERAL DESCRIPTION OF PTFE EXPANSION JOINTS

ACCESSORIES

STENFLEX® PTFE expansion joints can be equipped with the following accessories:

- internal guide sleeves
- protective covers

INTERNAL GUIDE SLEEVES

Normally internal guide sleeves are not required to reduce flow resistance because STENFLEX® PTFE expansion joints have a streamlined surface with large transition radii (flow lines).

However, abrasive media or high flow velocities with high-frequency vibrations or turbulence (such as occur behind a pump) make it necessary to install internal guide sleeves.

The internal guide sleeves are made of PTFE and are fitted with a flared flange.

In the case of purely axial movement, cylindrical internal guide sleeves are used. For lateral and/or angular movement, conical internal guide sleeves are fitted (tapered cross section).

It is very important to note the direction of flow when installing expansion joints with internal guide sleeves.

PROTECTIVE COVERS

STENFLEX® protective covers for expansion joints are used where special operating conditions make it necessary to protect the expansion joint from external effects, or where adverse operating conditions and dangerous flow media make it necessary to protect the environment with a preventive splash-guard.

Properties

- Flame-proof
- Flexible

Material

- Fabric

Use

As protective cover to prevent flame penetration up to +800°C for up to 30 min. to preserve the full operational ability of the expansion joint for this period.

Structure

Flexible flame-proof protection cover made of special fabric with heat-resistant insulation inlays; ready for installation with fastening screws to seal the cover.

Installation

The expansion joint is mounted as usual. The protective cover also encompasses the pipe flanges.



PTFE EXPANSION JOINTS

APPLICATIONS / POSSIBLE USES / INDUSTRIES

Basic expansion joint types		universal	lateral	universal	lateral	lateral
STENFLEX® Expansion joint types		Ai-1	Ai-2	P-1	P-2	P-4
Applications	Reducing tension	■	■	■	■	■
	Absorbing axial movement	■		■		
	Absorbing lateral movement	■	■	■	■	■
	Absorbing angular movement	■		■		
	Muffling oscillations at appliances	■	■	■	■	■
	Vibration damping	■	■	■	■	■
	Compensation for installation inaccuracies	■	■	■	■	■
Possible uses	Metal pipes	■	■	■	■	■
	Plastic pipes	■	■	■	■	■
	Pipes for aggressive media	■	■	■	■	■
	Pumps	■	■	■	■	■
	Fittings	■	■	■	■	■
Industries	Mechanical engineering	■	■	■	■	■
	Chemical industry	■	■	■	■	■
	Plant engineering	■	■	■	■	■
	Refuse incineration	■	■	■	■	■

Table showing prime applications, possible uses and industries

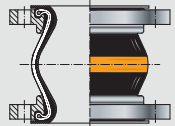
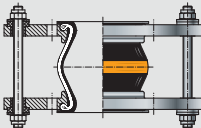
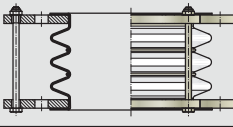
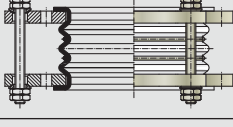
PROGRAM SUMMARY

	Type	DN	Pressure rate bar	Max. operating temperature	Bellows material	Connection parts	Page
	Ai-1	DN 40 - 500	PN 10	+90 °C	EPDM with PTFE lining	rotatable flanges	146
	Ai-2	DN 40 - 500	PN 10	+90 °C	EPDM with PTFE lining	rotatable flanges with tie rod restraint	148
	P-1	DN 25 - 500	PN 10,5	+200 °C	PTFE	rotatable flanges with transport lock	150
	P-2	DN 25 - 500	PN 10,5	+200 °C	PTFE	rotatable flanges with tie rod restraint	152
	P-4	DN 25 - 500	PN 10,5	+200 °C	PTFE	rotatable flanges with tie rod restraint	152

RUBBER EXPANSION JOINT WITH PTFE LINING TYPE AI-1 UNIVERSAL EXPANSION JOINT DN 40 – DN 500

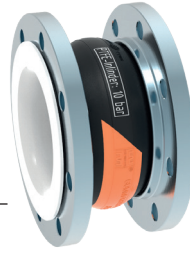

STRUCTURE TYPE AI-1 RUBBER BELLOWS WITH PTFE LINING PN 10

- Universal expansion joint consisting of a rubber bellows with seamless PTFE lining and rotatable flanges
- Flat-convoluted molded bellows made of EPDM
- Synthetic fibre reinforcement
- Wire-reinforced rubber rim
- Seamless PTFE lining with self-sealing flared ends

Material grade*	EPDM/PTFE, NBR/PTFE
Colour code	orange, red with stamp "PTFE-Inliner"
Einsatzmöglichkeiten	Chemicals, acids, lyes

*Check or inquire about the resistance of the rubber grade to temperature and medium

Technical calculation	
Max. perm. operating pressure	10 bar*
Max. permissible temperature	+100 °C
Bursting pressure	≥ 20 bar
Vacuum operation	not suitable

Max. operating pressure to be set 30 % lower for shock loads.

*Temperature related decrease of pressure (see technical annex page 198 rubber expansion joint Type A-1).

FLANGES / VERSIONS

- Rotatable flanges with stabilizing collar
- Flange drilling for through bolts
- Special machined groove for rubber rim

	Standard	Others
Dimensions	EN 1092	ANSI, BS etc. Connection dimensions see technical annex page 213 – 215
Materials	1.0038 (S235JR)	1.4541, 1.4571
Corrosion protection	electro-galvanized	hot-dip galvanized, special varnish, special coating etc.

NOTE

Please comply with the general technical instructions regarding reaction force, moving force, fixed point load, installation instructions etc.

Subject to technical alterations and deviations resulting from the manufacturing process.

APPLICATIONS

- for conveying aggressive media
 - very good chemical resistance
 - resistant to most of the acids and lyes
- for compensating axial, lateral and angular movement
- for muffling vibration and noise
- for reducing thermal and mechanical tension
- to compensate for installation inaccuracies
- chemical industry
- beverage industry

CERTIFICATES

- CE (PED 2014/68/EU)

ACCESSORIES

- Internal guide sleeve of PTFE
- Protective cover

DIMENSIONS STANDARD PROGRAM

DN	BL*	Pressure rate	Ø di** Bellows inner Ø	Ø C Raised face Ø	Ø W Convolution Ø unpressurized	PN Flange connection EN 1092	Ø D Flange outer Ø	b Flange thickness mm
	mm	bar	mm	mm	mm		mm	mm
40	131	10	33	92	86	16	150	16
50	131	10	43	101,5	97	16	165	16
65	131	10	59	127	113	16	185	18
80	156	10	71	133	135	16	200	20
100	156	10	94	171,5	160	16	220	20
125	156	10	121	192	184	16	250	22
150	157	10	146	218	212	16	285	22
175	157	10	169	248	236	16	315	22
200	182	10	195	273	265	10	340	25
250	182	10	245	328	318	10	395	25
300	207	10	296	378	373	10	445	25
350	212	10	332	438	420	10	505	30
400	212	10	384	206	460	10	565	30
450	262	10	423	230	575	10	615	35
500	262	10	473	260	625	10	670	35

*DN 40 - DN 125 also available as type Ri-1, length 136, DN 150 - DN 300 also available length 137.

**For manufacturing reasons the inner diameter may vary by ± 3 or ± 5 mm

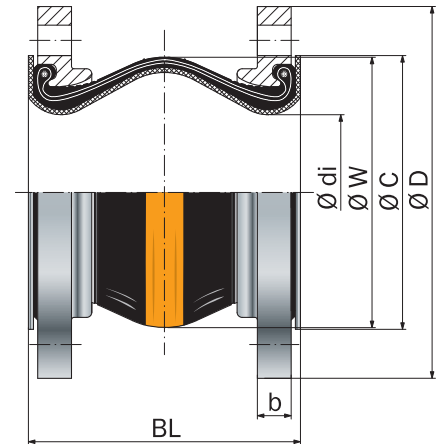

Type Ai-1

Universal expansion joint with PTFE lining

MOVEMENT COMPENSATION

DN	Δ ax Axial movement		Δ lat Lateral movement ± mm	Δ ang Angular movement ± ∠ degrees	A* Effective bellows cross sectional area at 10 bar cm ²	Weight approx. kg
	Compression - mm	Elongation + mm				
40	18	5	8	13	0	3.9
50	18	5	8	11	0	4.6
65	18	5	8	9	10	5.8
80	18	5	8	7	20	7.5
100	18	5	8	6	40	8.4
125	18	5	8	5	50	11.1
150	18	5	8	4	120	13.8
175	18	5	8	4	200	16.4
200	23	8	8	3	180	20.3
250	23	8	8	3	380	24.6
300	23	8	8	3	400	29.2
350	23	8	8	2.5	800	44.3
400	23	8	8	2.5	900	54.0
450	25	15	15	4.0	1500	70.3
500	25	15	15	3.5	1800	79.4

Please inquire for simultaneous (different) movement

*Effective bellows cross sectional area is a theoretical value

RUBBER EXPANSION JOINT WITH PTFE LINING TYPE AI-2

LATERAL EXPANSION JOINT DN 40 – DN 500

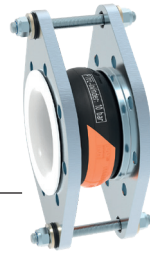

STRUCTURE TYPE AI-2 RUBBER BELLOWS WITH PTFE LINING PN 10

- Lateral expansion joint consisting of a rubber bellows with seamless PTFE lining and rotatable flanges, also with tie rods (external restraints) to absorb reaction force from internal pressure
- Flat-convoluted molded bellows made of EPDM
- Synthetic fibre reinforcement
- Wire-reinforced rubber rim
- Seamless PTFE lining with self-sealing flared ends, from DN 50 with inner PTFE supporting ring

Material grade*	EPDM/PTFE, NBR/PTFE
Colour code	orange, red with stamp "PTFE-Inliner"
Einsatzmöglichkeiten	Chemicals, acids, lyes

*Check or inquire about the resistance of the rubber grade to temperature and medium

Technical calculation	
Max. perm. operating pressure	10 bar*
Max. permissible temperature	+100 °C
Bursting pressure	≥ 20 bar
Vacuum operation	not suitable

Max. operating pressure to be set 30 % lower for shock loads.

*Temperature related decrease of pressure (see technical annex page 198 rubber expansion joint Type A-1).

FLANGES / VERSIONS

- Flanges with stabilizing collar and ears to carry the tie rods
- Flange drilling for through bolts
- Special machined groove for rubber rim

	Standard	Others
Dimensions	EN 1092	ANSI, BS etc. Connection dimensions see technical annex page 213 – 215
Materials	1.0038 (S235JR)	1.4541, 1.4571
Corrosion protection	electrogalvanized	hot-dip galvanized, special varnish, special coating etc.

NOTE

Please comply with the general technical instructions regarding reaction force, moving force, fixed point load, installation instructions etc.

Subject to technical alterations and deviations resulting from the manufacturing process.

APPLICATIONS

- for conveying aggressive media
 - very good chemical resistance
 - resistant to most acids and lyes
- for compensating lateral movement
- for muffling vibration and noise
- for reducing thermal and mechanical tension
- to compensate for installation inaccuracies
- chemical industry
- beverages industry

TIE ROD RESTRAINTS

- DN 40 – DN 150 Tie rods carried on silencing rubber sockets
- DN 175 – DN 500 Tie rods carried on spherical washers and conical seats

Materials

Standard: tie rods 8.8

Others: stainless steel

Corrosion protection

Standard: electrogalvanized

Others: hot-dip galvanized

CERTIFICATES

- CE (PED 2014/68/EU)

ACCESSORIES

- Internal guide sleeve of PTFE
- Protective cover

DIMENSIONS STANDARD PROGRAM

DN	BL*	Pressure rate	Ø di** Bellows inner Ø	Ø C Raised face Ø	Ø W Convolution Ø unpressurized	PN Flange connection EN 1092	Ø D Flange outer Ø	b Flange thickness	H Flange height
	mm	bar	mm	mm	mm		mm	mm	mm
40	131	10	33	92	86	16	150	16	230
50	131	10	43	101.5	97	16	165	16	240
65	131	10	59	127	113	16	185	18	260
80	156	10	71	133	135	16	200	20	300
100	156	10	94	171.5	160	16	220	20	350
125	156	10	121	192	184	16	250	22	385
150	157	10	146	218	212	16	285	22	420
175	157	10	169	248	236	16	315	22	440
200	182	10	195	273	265	10	340	25	465
250	182	10	245	328	318	10	395	25	520
300	207	10	296	378	373	10	445	25	570
350	212	10	332	438	420	10	505	30	630
400	212	10	384	489	460	10	565	30	690
450	262	10	423	539	575	10	615	35	795
500	262	10	473	594	625	10	670	35	850

*DN 40 - DN 125 also available as type Ri-2, length 136, DN 150 - DN 300 also available length 137.

**For manufacturing reasons the inner diameter may vary by ± 3 or ± 5 mm

MOVEMENT COMPENSATION / VERSIONS

DN	Δ lat Lateral movement ± mm	Weight approx. kg
40	8	5.6
50	8	6.3
65	8	7.6
80	8	11.0
100	8	13.0
125	8	17.3
150	8	20.3
175	8	21.0
200	8	25.0
250	8	29.2
300	8	34.0
350	8	50.9
400	8	63.0
450	15	92.0
500	15	105.4

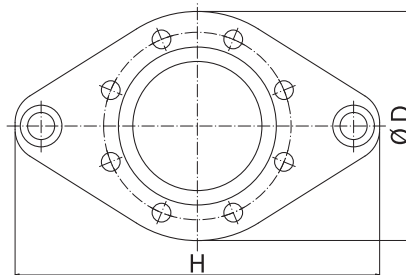

DN 40 - DN 150

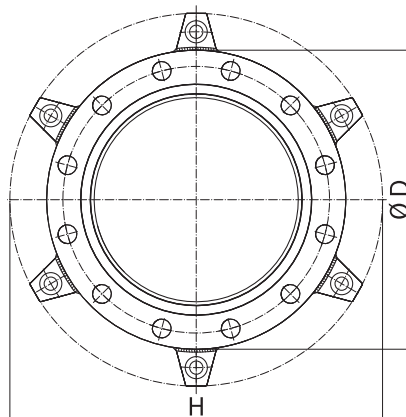

DN 175 - DN 500

Number of tie rods depending on pressure

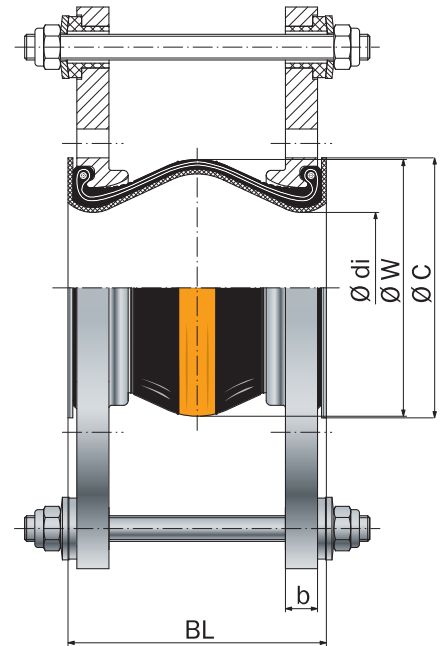

DN 40 - DN 150

Type Ai-2

Lateral expansion joint with PTFE lining, with tie rods (external restraints) carried on silencing rubber sockets.

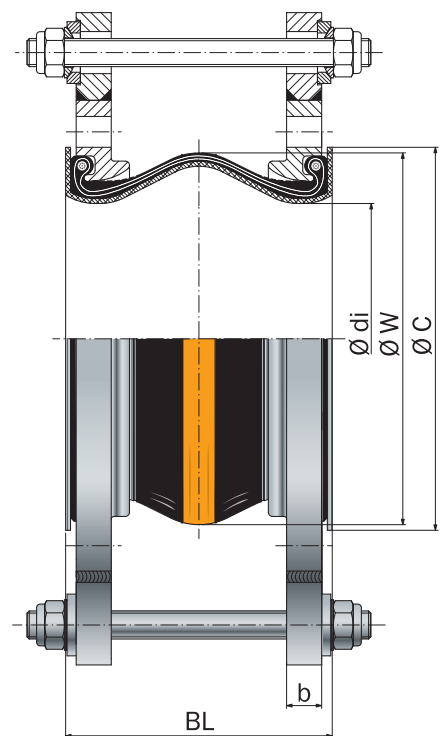

DN 175 - DN 500

Type Ai-2

Lateral expansion joint with PTFE lining, with tie rods (external restraints) carried on spherical washers and conical seats.

PTFE EXPANSION JOINT TYPE P-1

UNIVERSAL EXPANSION JOINT DN 15 – DN 500

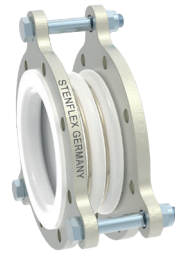

STRUCTURE TYPE P-1 PTFE BELLOWS PN 5,5, PN 9, PN 10,5

- Universal expansion joint consisting of PTFE bellows with rotatable flanges
- Multiple convolution bellows made of PTFE
- Outer supporting rings of stainless steel between the convolutions
- Bellows with self-sealing PTFE flange ends
- Inner surface repellent of foreign matter

Material quality*	Possible uses
PTFE	Aggressive acids and lyes, e.g., chloride, sulphate, solvents, bleaches, peroxide, fuels

*Check or inquire about the resistance of the material quality to temperature and medium

DN	DN 15 - 50	DN 65 - 100	DN 125 - 150	DN 200	DN 250 - 300	Temperature
max. perm. pressure rate bar	10	10	10	9,3	7,2	up to +23 °C
	10	8,3	6,9	4,9	3,2	up to +100 °C
	7,5	6,3	5,2	3,7	2,4	up to +150 °C
	5,3	4,7	3,6	3,1	1,7	up to +200 °C

DN	DN 15 - 100	DN 125 - 150	DN 200	DN 250	DN 300	Temperature
max. perm. vacuum operation bar	- 1,0	- 1,0	- 1,0	- 1,0	- 1,0	up to +23 °C
	- 1,0	- 1,0	- 1,0	- 1,0	- 1,0	up to +100 °C
	- 1,0	- 1,0	- 0,8	- 0,7	- 0,5	up to +150 °C
	- 1,0	- 0,8	- 0,55	- 0,45	- 0,35	up to +200 °C

Max. operating pressure should be set 30 % lower for shock load

FLANGES / VERSIONS

- Rotable flange
- threaded holes

	Standard	Others
Dimensions	EN 1092	ANSI, BS etc. Connection dimensions see technical annex page 213 - 215
Materials	1.0038 (S235JR)	1.4541, 1.4571
Corrosion protection	DN 15 - DN 300 electro-galvanized	DN 350 - DN 500 anti-corrosion primed
		hot-dip galvanized, special varnish, special coating etc.

NOTE

Additional PTFE seals necessary for installation in glass, graphite or ceramic pipes.

Type P1 is equipped with 3 check screws as transportation protection and to guarantee flawless installation. These are not impact-, or force-absorbing parts along the lines of tie rods, and must be removed after completing installation.

Please comply with general technical instructions regarding reaction force, adjusting force, fixed point load, installation instructions etc.

Subject to technical alterations and deviations resulting from the manufacturing process.

APPLICATIONS

- for conveying aggressive media
- for compensating axial, lateral and angular movements
- for muffling vibration and noise
- for reducing thermal and mechanical tension
- to compensate for installation inaccuracies
- chemical industry
- treatment and disposal technology
- pharmaceutical industry

ACCESSORIES

- Internal guide sleeve of PTFE
- Protective cover
- Transport protection (included)

DIMENSIONS STANDARD PROGRAM

DN	BL	Ø K Bolt circle diameter Ø mm	Ø C Raised face Ø mm	S _{min} min. Flare thicknes mm	b Flange thickness mm
15	70	65	45	3.0	13.0
20	70	75	58	3.0	13.0
25	70	85	68	3.0	13.0
32	75	100	78	3.0	13.0
40	80	110	88	3.0	13.0
50	85	125	102	4.0	16.0
65	100	145	122	4.0	16.0
80	110	160	138	4.0	16.0
100	110	180	158	5.0	20.0
125	120	210	188	4.5	19.5
150	130	240	212	5.0	23.0
200	140	295	268	5.0	25.0
250	165	350	320	7.5	29.5
300	175	400	370	6.0	31.0
350	190	460	430	7.5	37.5
400	190	515	482	7.5	37.5
500	190	620	585	8.0	38.0

Larger DN's other structural lengths, higher pressures, other movement absorption available on request. Dimensions according to GR 12-0040 standard available on request.

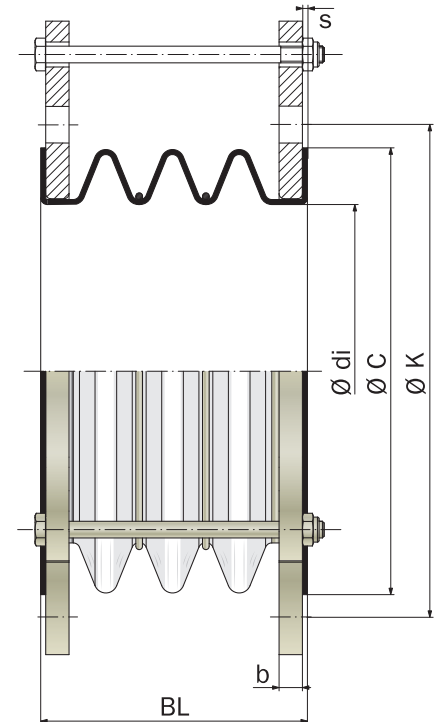

Type P-1

Universal PTFE expansion joint with transportation safeguard

P-1 available with 2 or 3 convolutions

MOVEMENT COMPENSATION

DN	Δ ax Axial movement ± mm	Δ lat Lateral movement ± mm	Δ ang Angular movement ± ∠ Grad	Weight approx. kg
15	10	6	6	1.4
20	10	6	6	1.7
25	10	6	6	2.0
32	10	6	6	2.8
40	15	6	6	3.3
50	15	9	8	4.6
65	20	9	8	5.5
80	20	13	10	6.6
100	25	13	10	9.0
125	25	14	10	12.0
150	25	14	8	17.0
200	30	14	8	27.4
250	30	14	6	35.5
300	30	15	6	57.9
350	30	15	6	78.8
400	35	15	6	90.2
500	35	20	5	101.9

Please inquire for simultaneous (different) movement
Table values refer to +20 °C and triple convoluted expansion joints
*Effective bellows cross sectional area is a theoretical value.

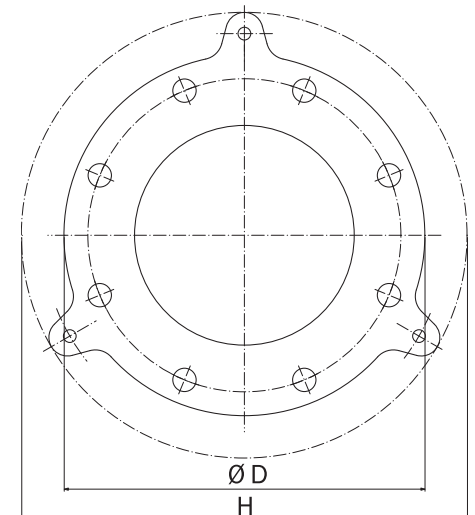

Molded ears for restraint as transportation safeguard only

PTFE EXPANSION JOINT TYPE P-2, P-4

LATERAL EXPANSION JOINT DN 15 – DN 500



STRUCTURE TYPE P-2, P-4 PTFE BELLOWS PN 5,5, PN 9, PN 10,5

- **Type P-2:** Lateral expansion joint consisting of a PTFE bellows and rotatable flanges with tie rods (external restraints) to absorb reaction force from internal pressure
- **Type P-4:** Lateral expansion joint consisting of a PTFE bellows and rotatable flanges with tie rods (external and internal restraints) to absorb reaction force from internal pressure or vacuum
- Multiple convolution bellows made of PTFE
- Outer stabilizing rings of stainless steel between the convolutions
- Self-sealing PTFE flared ends
- Inner surface repellent of foreign matter

Material quality*	Possible uses
PTFE	Aggressive acids and lyes, e.g., chloride, sulphate, solvents, bleaches, peroxide, fuels

*Check or inquire about the resistance of the material quality to temperature and medium

Technical calculation			
DN	DN 200 – 500	DN 125 – 150	DN 15 – 100
Pressure rate	PN 5,5	PN 9	PN 10,5
Max. perm. operating pressure			
up to +20 °C	5,5 bar	9,0 bar	10,5 bar
up to +100 °C	3,5 bar	5,5 bar	7 bar
up to +150 °C	2,5 bar	4,0 bar	4 bar
up to +200 °C	1,7 bar	2,5 bar	3 bar
Vacuum operation	≥ 0,01 bar abs. DN 15 – 150 ≥ 0,20 bar abs. DN 200 – 250 ≥ 0,70 bar abs. DN 300 – 500		

Max. operating pressure to be set 30 % lower for shock loads.

FLANGES / VERSIONS

- Rotatable flanges with ears to carry tie rods
- threaded holes

	Standard		Others
Dimensions	EN 1092		ANSI, BS etc. Connection dimensions see technical annex page 213 – 215
Materials	1.0038 (S235JR)		1.4541, 1.4571
Corrosion protection	DN 15 – DN 300 electro-galvanized	DN 350 – DN 500 anti-corrosion primed	special varnish, special coating etc.

NOTE

Additional PTFE gaskets necessary for installation in glass, graphite or ceramic pipes.

Please comply with the general technical instructions regarding reaction force, moving force, fixed point load, installation instructions etc.

Subject to technical alterations and deviations resulting from the manufacturing process.

APPLICATIONS

- for conveying aggressive media
- for compensating lateral movement
- for muffling vibration and noise
- for reducing thermal and mechanical tension
- to compensate for installation inaccuracies
- chemical industry
- treatment and disposal technology
- pharmaceutical industry

TIE ROD RESTRAINTS

- Tie rods carried on spherical washers and conical seats

Materials

Standard: tie rods 8.8

Others: stainless steel

Corrosion protection

Standard: electrogalvanized

Others: hot-dip galvanized

ACCESSORIES

- Internal guide sleeve of PTFE
- Protective cover

DIMENSIONS STANDARD PROGRAM

DN	BL*	Pressure rate	Ø di** Bellows inner Ø	Ø C Raised face Ø	PN Flange connection EN 1092	Ø D Flange outer Ø	b Flange thickness	H Flange height
	mm	bar	mm	mm		mm	mm	mm
15	46	10.5	21.5	45	16	95	8	143
20	46	10.5	21.5	58	16	105	8	153
25	46	10.5	21.5	68	16	115	8	163
32	46	10.5	34.5	78	16	140	10	194
40	46	10.5	34.5	88	16	150	10	204
50	56	10.5	48.3	102	16	165	12	219
65	77	10.5	58.5	122	16	185	12	239
80	77	10.5	73.2	138	16	200	12	267
100	91	10.5	99.3	158	16	220	15	287
125	111	9.0	123.0	188	16	250	15	330
150	101	9.0	147.8	212	16	285	18	370
200	137	5.5	205.1	268	10	340	20	460
250	200	5.5	256.6	320	10	395	22	515
300	196	5.5	280.5	370	10	445	25	605
350	215	5.5			10			
400	233	5.5			10			
450	280	5.5	on request	on request	10	on request	on request	on request
500	327	5.5	on request	on request	10	on request	on request	on request

Larger sizes (DN), other lengths (BL), higher pressure rate, different movement compensation available on request.

Dimensions according to GR 12-0040 standard available on request.

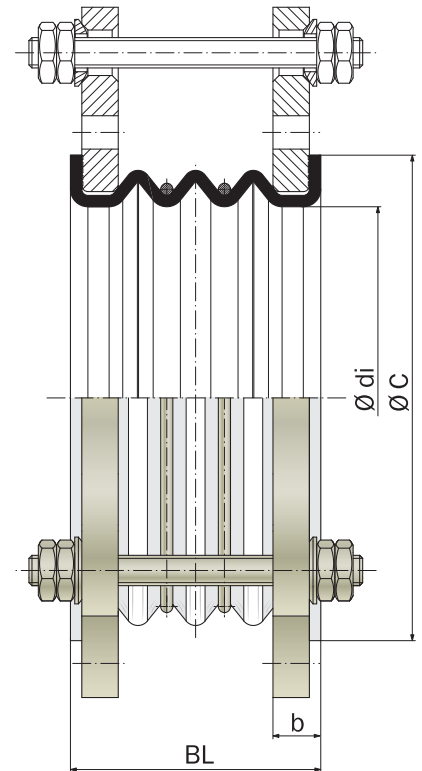

Type P-2

Lateral PTFE expansion joint, with tie rods (external restraints) carried on spherical washers and conical seats

MOVEMENT COMPENSATION / VERSIONS

DN	Δ lat Lateral movement ± mm	Weight approx. kg
15	4	1.7
20	4	2.1
25	6	2.3
32	6	2.8
40	6	3.1
50	9	4.3
65	9	5.1
80	13	5.8
100	13	7.5
125	14	11.9
150	14	13.2
200	14	21.5
250	14	27.7
300	15	35.8
350	18	61.0
400	20	76.0
450	20	92.0
500	25	112.0

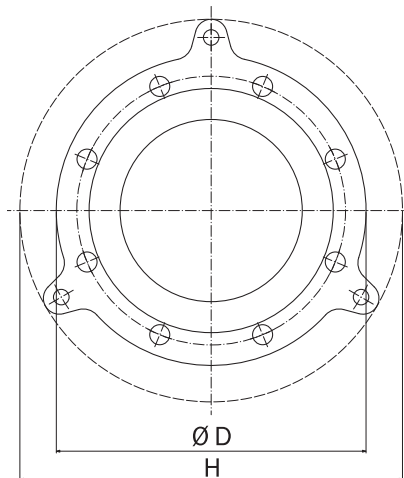

Number of tie rods depending on pressure

Table values refer to +20 °C and triple-convoluted expansion joints

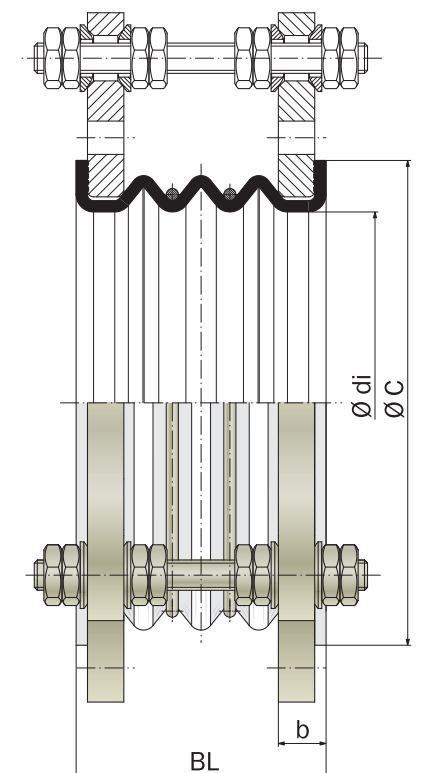

Type P-4

Lateral PTFE expansion joint, design as type P-2, additional internal restraints, carried on spherical washers and conical seats.

SWIVEL JOINTS PROGRAMME OVERVIEW

STENFLEX® **SWIVEL JOINTS** ARE SUITABLE FOR LIQUID AND GASEOUS MEDIA. THEIR ABILITY TO WITHSTAND EXTREME TEMPERATURE AND PRESSURE MEANS THAT THEY CAN BE USED AS FLEXIBLE PIPE CONNECTION ELEMENTS EVEN UNDER THE MOST DEMANDING OPERATING CONDITIONS.

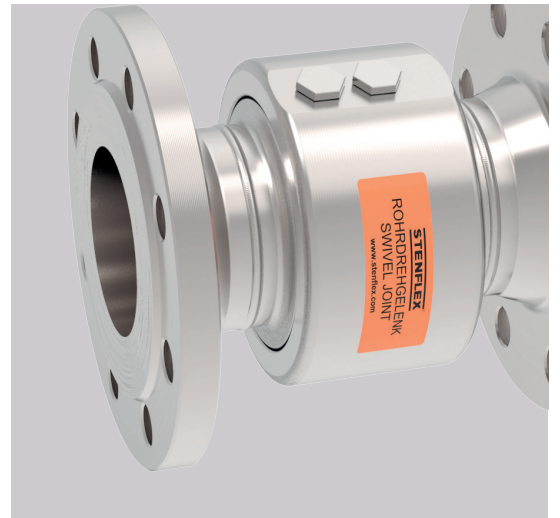

QUALITY.

SWIVEL JOINTS

APPLICATIONS / POSSIBLE USES

STENFLEX® Swivel Joints are used as rotating pipe connection elements and installed in flexible pressurised pipeline systems. They are the ideal connection element under rough operating conditions and at high pressures.

They are suitable for liquid and gaseous media at temperatures from -20 °C to +240 °C.

Swivel Joints are suitable for absorbing torsion movements. They allow not only for swivelling movements but also for complete rotations at low speed.

Frequently, Swivel Joints are used in a 2- or 3-joint system to absorb larger movements. Large angular or lateral movements are also possible when the joints are arranged accordingly.

STENFLEX® Swivel Joints in pipeline systems allow for the media to be conveyed from a fixed point to any required flexible point.

Swivel Joints give scope for many versatile design possibilities and are used, among others,

- in loading and swivelling arms
- in pipe joint shears
- in hydraulic flow pipes
- at roll stands
- at sewage activation basins
- for filling processes on open terrain
- in steel, rolling and foundry mills

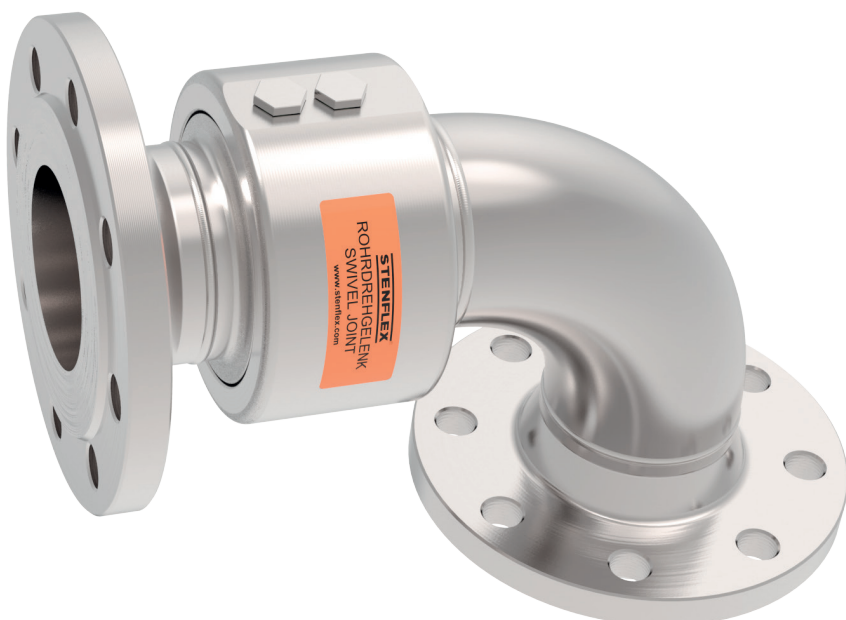
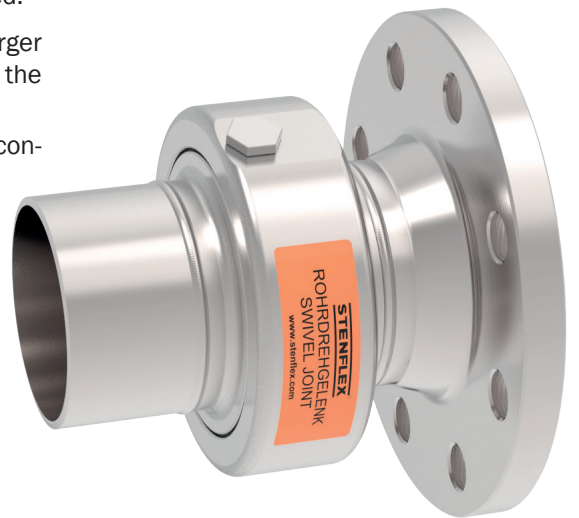

SWIVEL JOINTS

POSSIBLE USES / APPLICATIONS / TECHNICAL DATA

STENFLEX® Swivel Joint types		DG-01	DG-02L	DG-02S	DK-01	DK-02
Possible uses	Sewage plant	■	■	■		
	Foundry mills	■	■	■	■	■
	Steel mills	■	■	■	■	■
	Rolling mills	■	■	■	■	■
	Test facilities	■	■	■	■	■
	Hydraulic pipes	■	■	■	■	■
	Filling systems	■	■	■	■	■
	Hose drums	■	■	■	■	■
	Pipe joint shears	■	■	■	■	■
	Loading and swivelling arms	■	■	■	■	■
	Special desings for food product applications	■	■	■	■	■
	Applications	Absorption of thermal pipeline expansion via flexible lines with joints	■	■	■	■
2- or 3-joint system for absorption of large lateral movements		■	■	■	■	■
Rotary movements 360°		■	■	■	■	■
Swivel movements		■	■	■	■	■
for high temperatures		■	■	■	■	■
for particularly high pressures				■		■
for rough operating conditions		■	■	■	■	■
for liquid and gaseous media	■	■	■	■	■	
Technical Data	Design 11: straight	■	■	■	■	■
	Design 12: angled on one side	■	■	■	■	■
	Design 13: angled both sides	■	■	■	■	■
	Flange connection	■	■	■		
	Welded end	■	■	■		
	Threaded connection	□		□	■	■
	Material: 1.7225 (42CrMo4)	■	■	■	■	■
	Material: 1.4571 (X6CrNiMoTi17122)	■	■	■	■	■
	Smallest dimension DN	20	125	20	8	8
	Largest dimension DN	100	700	300	50	50
	max. operating pressure 1.4571/1.7225 in bar	40/100	16/40	100/350	40/100	100/350
	max. operating temperature in °C	260	260	260	260	260
	Ball rows	1	2	2	1	2
	Inner sealing for polluted media	□	□	□	□	□
	Hermetic external sealing		□	□ ab DN 65		
Special sealing for oxygen, steam and food products	□	□	□	□	□	

■ Standard design / □ Special design

SWIVEL JOINTS

STRUCTURE

BASIC UNIT

The basic unit of all Swivel Joints is the joint head. It consists of an outer part (stator) and an inner part (rotor). These are joined positively by a single- or two-row bearing (see illustration). For mantling/dismantling the balls special bungs are used to safeguard the balls and prevent any impurities from penetrating the bearing.

- A for-life lubrication provided in the factory
- B medium sealing
- C external dust sealing
- D ball
- E inner sealing
- F inner part (rotor)
- G outer part (stator)
- I thread plug

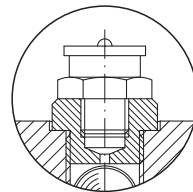

lubricating nipple, only on request

The ball bearing is provided with for life lubrication in the factory. A lubricating nipple is possible on request.

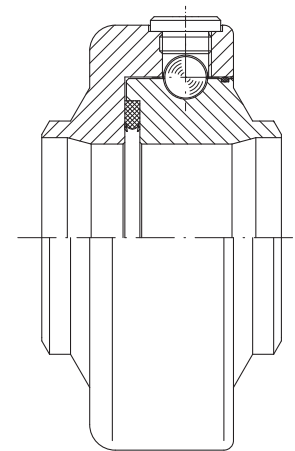
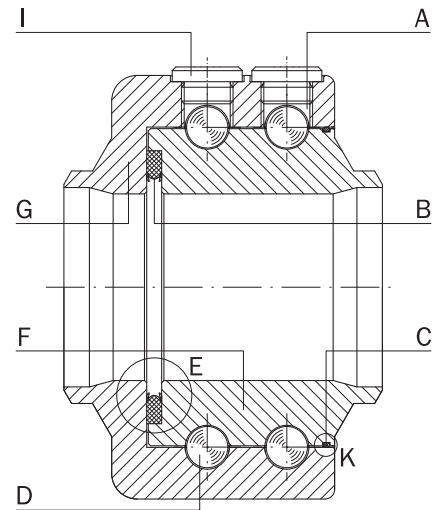

Type DG-01 PN 100
with single-row ball bearing

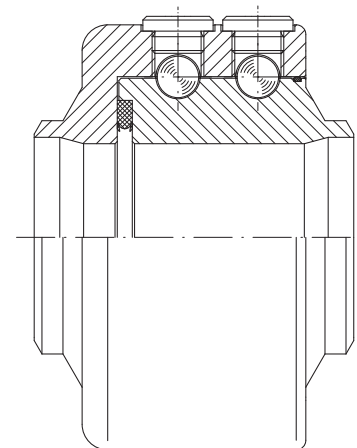

Type DG-02 PN 350
with two-row ball bearing

STANDARD SEALINGS

The axial working sealing B (PTFE) between stator and rotor seals off against the medium. It is installed with pre-tension and is geometrically designed in such a way that the inner pressure of the medium increases the axial pressing force of the sealing ring. The outer radial sealing C protects the swivel joint from external influences.

SPECIAL SEALINGS

A special hermetic sealing K is available for underwater applications. For heavily polluted media an additional inner sealing can be fitted. Further special sealings are available for oxygen, steam and food products.

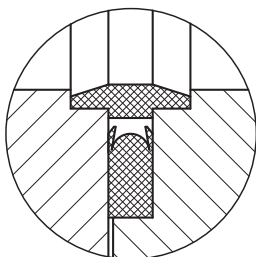

E Additional inner sealing for polluted media (special design)

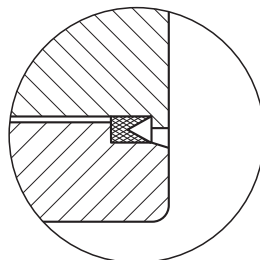

K Hermetic sealing for underwater applications (special design)

SURFACE PROTECTION

After the welding process, the Swivel Joints of material 1.7225 are gas nitrided. The influence of nitrogen increases wear resistance and corrosion protection.

In addition, all Swivel Joints are provided with a corrosion-protection primer.

	Materials	
Basic unit	1.7225 (42 CrMo 4)	1.4571 (X6 CrNiMoTi 17122)
Welding end	1.0305 (St 35.8)	1.4571 (X6 CrNiMoTi 17122)
Flange	1.0460 (C 22.8)	1.4571 (X6 CrNiMoTi 17122)

SWIVEL JOINTS

CONNECTIONS / INTERPRETATION / TESTS

CONNECTIONS

The Swivel Joint is supplied in the combination joint head (basic unit) with the corresponding connections.

Connection types include for example flange, welding end or threaded connection. The connections are permanently attached to the basic unit.

There are three different forms for Swivel Joints:

- Form **11**: Straight version
- Form **12**: Version angled on one side with a 90° elbow
- Form **13**: Version angled on two sides with two 90° elbows

The series are given an additional identification suffix depending on the connection type:

- Index **F**: flange
- Index **S**: welding end
- Index **IG**: female thread
- Index **AG**: male thread

TEMPERATURE RANGE

-20 °C to +240 °C

PRESSURE RATINGS

Single-row ball bearing: adm. operating pressure max. 100 bar

Two-row ball bearing: adm. operating pressure max. 350 bar, 420 bar on request

Vacuum to 0.1 bar (abs.)

The max. operating pressure applies to the basic unit only and is limited to ambient temperature 20°C.

The operating pressures are to be reduced accordingly depending on materials, operating pressure and pressure stage of the corresponding connections.

Please ask for reduction factors to be taken into consideration.

TOLERANCES

The tolerances of the tubular axle distances L₁ up to L₇ in the data sheets should be requested.

NOTE

STENFLEX® Swivel Joints are designed for slow swivel or rotation movements (max. 10 rpm) and are therefore not suitable for fast-running rotations, e.g. feed heads at rollers etc.

STENFLEX® Swivel Joints DV-02 (rotation screwed unions) are suitable for rotation movements up to max. 40 rpm.

Swivel Joints which deviate from the standard design are manufactured as special models and adjusted specially to customer requirements, e.g.

- higher operating pressure
- other connections
- piggable design
- oxygen operation
- toxic media
- high and low temperature
- rotation movements (over 10 rpm)

TESTS

In order to safeguard a constantly high quality of STENFLEX® Swivel Joints, specially trained staff are responsible for on-going in-process monitoring throughout the production process.

The standard tests include:

- visual tests
- dimension checks of the individual components or groups

In addition, we use the services of experts and classification societies for acceptance testing including corresponding documentation.

These acceptance tests refer essentially to:

- completeness checks
- visual and dimension checks
- leak and/or pressure tests
- checking the compiled documentation

SWIVEL JOINTS

PLANES OF ROTATION

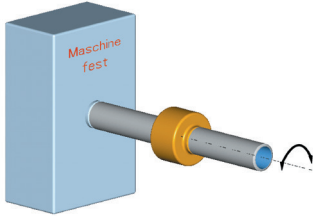

Type 11S
Slow rotary movement with type 11S (1 fixed point, 1 side flexible)

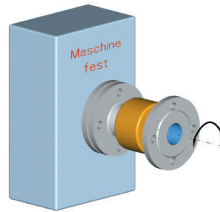

Type 11F
Slow rotary movement with type 11F (1 fixed point, 1 side flexible)

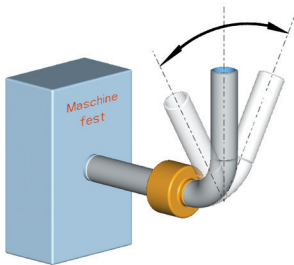

Type 12S
Swivel movement with type 12S (1 fixed point, 1 side flexible)

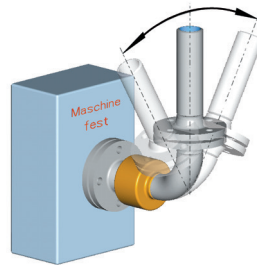

Type 12F
Swivel movement with type 12F (1 fixed point, 1 side flexible)

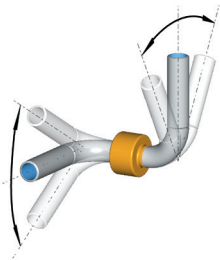

Type 13S
Swivel movement on both sides with type 13S in angled pipe piece

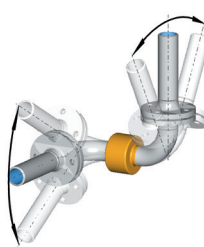

Type 13F
Swivel movement on both sides with type 13F in angled pipe piece

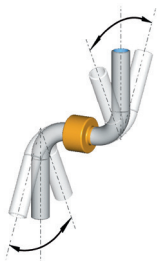

Type 13S
Swivel movement on both sides with type 13S in straight pipe piece

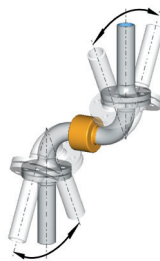

Type 13F
Swivel movement on both sides with type 13F in straight pipe piece

Before stipulating the Swivel Joint type, it is important to decide how the movement is to be effected in the pipeline system. The type is selected essentially depending on the routing of the pipeline, required movement, space available and type of pipeline connections.

A differentiation is made between rotating and swivelling movements when positioning the joints in the pipeline system. The joints can be integrated in the line by means of flanges, welded connections or threaded connections.

SWIVEL JOINTS

FORMS

STENFLEX® Swivel Joints are produced in two type series.

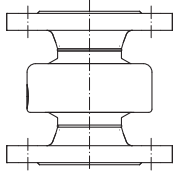
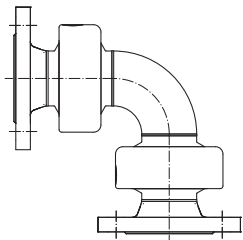
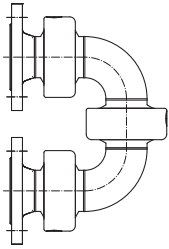
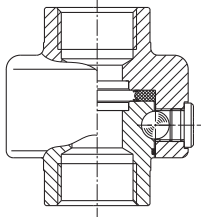
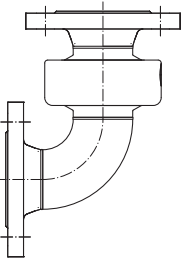
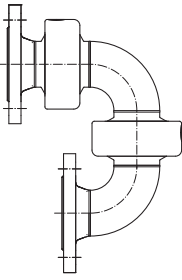
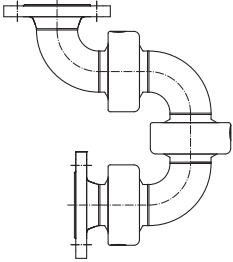
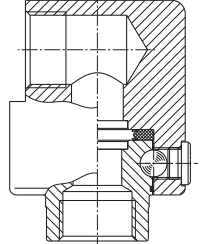
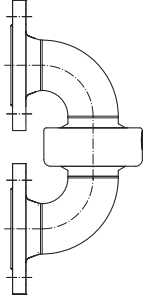
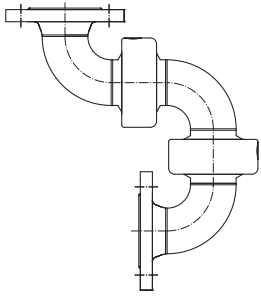
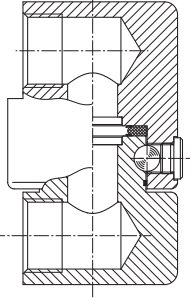
STENFLEX®	Swivel Joints			Rotating head joints
Types	DG-01 DG-02L (light-weight design) DG-02S (heavy-duty design)			DK-01 DK-02
Forms	DG			DK
	one plane of rotation	two plane of rotation	three plane of rotation	one plane of rotation
	form 11 	form 24 	form 37 	form 11 
	form 12 	form 25 	form 38 	form 12 
form 13 	form 26 		form 13 	
Connections	DG-01: flange welding end male thread (special design) female thread (special design) DG-02L: flange welding end DG-02S: flange welding end male thread (special design) female thread (special design)			DK-01: female thread DK-02: female thread

Special connections (combinations of different connections) possible.

SWIVEL JOINT TYPE DG-01

DN 20 – DN 100



STRUCTURE / DESIGN

- stator (outer part) and rotor (inner part) joined by a single-row ball bearing
- for-life lubrication provided in the factory
- welded connection parts: welding ends, pipe bends or flanges

	Materials	
Basic unit	1.7225	1.4571
Welding end	1.0305	1.4571
Flange	1.0460	1.4571

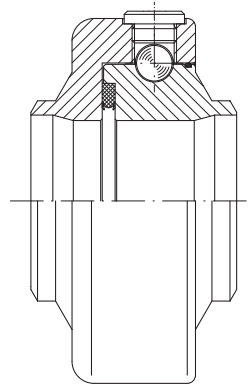

Type DG-01 basic unit
with single-row ball bearing

	Dimensions
Standard:	DN 20 bis DN 100
Flanges:	PN 16 to EN 1092
Others:	possible to ANSI (ASA), BS etc.
Welding end:	nto ISO recommendations

STANDARD SEALINGS

- PTFE compound sealings

SPECIAL SEALINGS

- additional inner sealing for heavily polluted media
- medium sealings for oxygen, steam and food products

Pressure rating

- PN 16 (1.7225) with flanges
- PN 100 (1.7225) with welding ends
- PN 16 (1.4571) with flanges
- PN 40 (1.4571) with welding ends

Surface protection

- Gas nitration
- Corrosion-protection primer

NOTE

General technical instructions must be observed. Subject to technical alterations and fluctuations caused by the production process.

Number of revolutions for swivel and rotation movements ≤ 10 rpm.

Swivel movements in several planes see catalogue page 160.

Sets of sealings and balls available individually as spare parts.

APPLICATIONS

- for liquid or gaseous media at high temperatures and pressures
- for slow swivel and rotation movements through 360°
- for rough operating conditions
 - in hydraulic flow pipes
 - at roll stands
 - in sewage plant
 - in steel mills
 - at hose drums
- for installation in flexible pipeline systems, for conveying media from a fixed point to any required flexible point
 - filling systems
 - loading and swivel arms
 - pipe joint shears
- use at test facilities
- special designs suitable for food products

Form 11 F flange connection*		DN	Ø D ₁ mm	1.7225/1.4571/PN 16	
				Ø D mm	L mm
		20	72	105	139
		25	78	115	144
		32	88	140	148
		40	96	150	154
		50	118	165	164
		65	133	185	169
		80	139	200	179
		100	164	220	183

Bauform 11 S welding ends		DN	Ø D ₁ mm	1.7225/PN 100			1.4571/PN 40		
				Ø d _a mm	s mm	L ₄ mm	Ø d _a mm	s mm	L ₄ mm
		20	72	26.9	2.9	159	26.9	2.9	159
		25	78	33.7	3.4	164	33.7	3.4	164
		32	88	42.4	3.6	164	42.4	3.6	164
		40	96	48.3	3.7	164	48.3	3.7	164
		50	118	60.3	3.9	174	60.3	3.9	174
		65	133	73.0	5.2	179	73.0	5.2	179
		80	139	88.9	5.5	179	88.9	5.5	179
		100	164	114.3	6.0	179	114.3	6.0	179

Bauform 12 F flange connection*		DN	Ø D ₁ mm	1.7225/PN 16			1.4571/PN 16		
				Ø D mm	L ₂ mm	L ₃ mm	Ø D mm	L ₂ mm	L ₃ mm
		20	72	105	124	67	105	137	80
		25	78	115	129	67	115	142	80
		32	88	140	138	76	140	154	92
		40	96	150	147	85	150	166	104
		50	118	165	170	98	165	195	123
		65	133	185	187	110	185	219	142
		80	139	200	205	128	200	243	166
		100	164	220	233	156	220	283	206

Bauform 12 S welding ends		DN	Ø D ₁ mm	1.7225/PN 100				1.4571/PN 40			
				Ø d _a mm	s mm	L ₅ mm	L ₆ mm	Ø d _a mm	s mm	L ₅ mm	L ₆ mm
		20	72	26.9	2.9	134	25	26.9	2.9	138	29
		25	78	33.7	3.4	139	25	33.7	3.4	152	38
		32	88	42.4	3.6	146	32	42.4	3.6	162	48
		40	96	48.3	3.7	152	38	48.3	3.7	171	57
		50	118	60.3	3.9	175	51	60.3	3.9	200	76
		65	133	76.1	5.2	192	63	73.0	5.2	224	95
		80	139	88.9	5.5	205	76	88.9	5.5	243	114
		100	164	114.3	6.0	231	102	114.3	6.0	281	152

Bauform 13 F flange connection*		DN	Ø D ₁ mm	1.7225/PN 16			1.4571/PN 16		
				Ø D mm	L ₁ mm	L ₃ mm	Ø D mm	L ₁ mm	L ₃ mm
		20	72	105	109	67	105	135	80
		25	78	115	114	67	115	140	80
		32	88	140	128	76	140	160	92
		40	96	150	140	85	150	178	104
		50	118	165	176	98	165	226	123
		65	133	185	205	110	185	269	142
		80	139	200	231	128	200	307	166
		100	164	220	283	156	220	383	206

Bauform 13 S welding ends		DN	Ø D ₁ mm	1.7225/PN 100				1.4571/PN 40			
				Ø d _a mm	s mm	L ₆ mm	L ₇ mm	Ø d _a mm	s mm	L ₆ mm	L ₇ mm
		20	72	26.9	2.9	25	109	26.9	2.9	29	117
		25	78	33.7	3.4	25	114	33.7	3.4	38	140
		32	88	42.4	3.6	32	128	42.4	3.6	48	160
		40	96	48.3	3.7	38	140	48.3	3.7	57	178
		50	118	60.3	3.9	51	176	60.3	3.9	76	226
		65	133	76.1	5.2	63	205	73.0	5.2	95	269
		80	139	88.9	5.5	76	231	88.9	5.5	114	307
		100	164	114.3	6.0	102	283	114.3	6.0	152	383

*PN 40 flange connection possible on request. Materials data stated for basic units.

SWIVEL JOINT TYPE DG-02L

DN 125 – DN 700

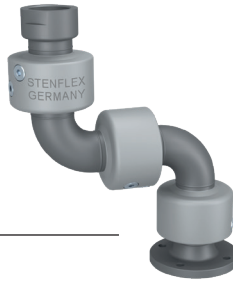

STRUCTURE / DESIGN

- stator (outer part) and rotor (inner part) joined by a two-row ball bearing
- for-life lubrication provided in the factory
- welded connection parts: welding ends, pipe bends or flanges

	Materials	
Basic unit	1.7225	1.4571
Welding end	1.0305	1.4571
Flange	1.0460	1.4571

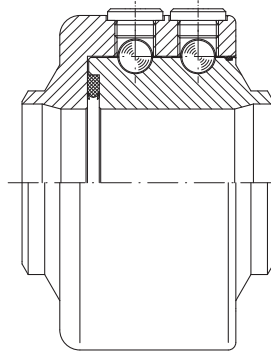

Type DG-02L basic unit
with two-row ball bearing

	Dimensions
Standard:	DN 125 bis DN 700
Flanges:	PN 10/16 to EN 1092
Others:	possible to ANSI (ASA), BS etc.
Welding end:	nto ISO recommendations

STANDARD SEALINGS

- PTFE compound sealings

SPECIAL SEALINGS

- additional inner sealing for heavily polluted media
- hermetic radial sealing for underwater applications (from DN 65)
- medium sealings for oxygen, steam and food products

Pressure rating

- PN 10, PN 16 (1.7225) with flanges
- PN 16, PN 40 (1.7225) with welding ends
- PN 10, PN 16 (1.4571) with flanges
- PN 6, PN 16 (1.4571) with welding ends

Surface protection

- Gas nitration
- Corrosion-protection primer

NOTE

General technical instructions must be observed. Subject to technical alterations and fluctuations caused by the production process.

Number of revolutions for swivel and rotation movements ≤ 10 rpm.

Swivel movements in several planes see catalogue page 160.

Sets of sealings and balls available individually as spare parts.

APPLICATIONS

- for liquid or gaseous media at high temperatures and pressures
- for slow swivel and rotation movements through 360°
- for rough operating conditions
 - in hydraulic flow pipes
 - at roll stands
 - in sewage plant
 - in steel mills
 - at hose drums
- for installation in flexible pipeline systems, for conveying media from a fixed point to any required flexible point
 - filling systems
 - loading and swivel arms
 - pipe joint shears
- use at test facilities
- special designs suitable for food products

Form 11 F flange connection*		DN	Ø D ₁ mm	1.7225/PN 10		1.722/ PN 16		1.4571/PN 10		1.4571/PN 16	
				Ø D mm	L mm	Ø D mm	L mm	Ø D mm	L mm	Ø D mm	L mm
		125	197			250	241			250	241
150	223			285	251			285	251		
200	277	340	263	340	263	340	265	340	263		
250	325	395	277	405	281	395	277	405	281		
300	390	445	282	460	302	445	282	460	302		
350	420	505	282	520	310	505	282	520	310		
400	470	565	290	580	316	565	290	580	316		
500	590	670	296	715	326	670	296	715	326		

Form 11 S welding ends		DN	Ø D ₁ mm	Ø d _a mm	1.7225/PN 16		1.7225/PN 40		1.4571/PN 6		1.4571/PN 16	
					s mm	L ₄ mm	s mm	L ₄ mm	s mm	L ₄ mm	s mm	L ₄ mm
		125	197	141,3	6,6	229	6,6	229	6,6	229	6,6	229
150	223	168,3	7,1	239	7,1	229	7,1	239	7,1	239	7,1	239
200	277	219,1	8,2	239	8,2	239	8,2	239	8,2	239	8,2	239
250	325	273,0	9,3	241	9,3	214	9,3	241	9,3	241	9,3	241
300	390	323,9	11,5	246	11,5	246	11,5	246	11,5	246	11,5	246
350	420	355,6	8,0	246				8,0	246			
400	470	406,4	8,8	246				8,8	246			
500	590	508,0	9,5	246				9,5	246			

Form 12 F flange connection*		DN	Ø D ₁ mm	1.7225/PN 10			1.7225/PN 16			1.4571/PN 10			1.4571/PN 16		
				Ø D mm	L ₂ mm	L ₃ mm	Ø D mm	L ₂ mm	L ₃ mm	Ø D mm	L ₂ mm	L ₃ mm	Ø D mm	L ₂ mm	L ₃ mm
		125	197					250	311	184				250	374
150	223					285	346	209				285	423	286	
200	277	340	404	267	340	404	267	340	506	369	340	506	369		
250	325	395	463	325	405	465	327	395	590	454	405	592	454		
300	390	445	519	376	460	529	386	445	671	538	460	681	538		
350	420	505	570	427	520	584	441	505	747	618	520	761	618		
400	470	565	624	481	580	637	494	565	828	698	580	841	698		
500	590	670	729	586	715	744	601	670	983	855	715	998	855		

Form 12 S welding ends		DN	Ø D ₁ mm	Ø d _a mm	1.7225/PN 16			1.7225/PN 40			1.4571/PN 6			1.4571/PN 16		
					s mm	L ₅ mm	L ₆ mm	s mm	L ₅ mm	L ₆ mm	s mm	L ₅ mm	L ₆ mm	s mm	L ₅ mm	L ₆ mm
		125	197	141,3	6,6	306	127	6,6	306	127	6,6	369	190	6,6	369	190
150	223	168,3	7,1	341	152	7,1	341	152	7,1	418	229	7,1	418	229		
200	277	219,1	8,2	392	203	8,2	392	203	8,2	494	305	8,2	494	305		
250	325	273,0	9,3	445	254	9,3	445	254	9,3	572	381	9,3	572	381		
300	390	323,9	11,5	501	305	11,5	501	305	11,5	653	457	11,5	653	457		
350	420	355,6	8,0	552	356				8,0	729	533					
400	470	406,4	8,8	602	406				8,8	806	610					
500	590	508,0	9,5	704	508				9,5	958	762					

Form 13 F flange connection*		DN	Ø D ₁ mm	1.7225/PN 10			1.7225/PN 16			1.4571/PN 10			1.4571/PN 16		
				Ø D mm	L ₁ mm	L ₃ mm	Ø D mm	L ₁ mm	L ₃ mm	Ø D mm	L ₁ mm	L ₃ mm	Ø D mm	L ₁ mm	L ₃ mm
		125	197					250	383	184				250	509
150	223					285	443	209				285	597	286	
200	277	340	545	267	340	545	267	340	749	369	340	749	369		
250	325	395	649	325	405	649	327	395	903	454	405	903	454		
300	390	445	756	376	460	756	386	445	1060	538	460	1060	538		
350	420	505	858	427	520	858	441	505	1212	618	520	1212	618		
400	470	565	958	481	580	958	494	565	1366	698	580	1366	698		
500	590	670	1162	586	715	1162	601	670	1670	855	715	1670	855		

Form 13 S welding ends		DN	Ø D ₁ mm	Ø d _a mm	1.7225/PN 16			1.7225/PN 40			1.4571/PN 6			1.4571/PN 16		
					s mm	L ₆ mm	L ₇ mm	s mm	L ₆ mm	L ₇ mm	s mm	L ₆ mm	L ₇ mm	s mm	L ₆ mm	L ₇ mm
		125	197	141,3	6,6	127	383	6,6	127	383	6,6	190	509	6,6	190	509
150	223	168,3	7,1	152	443	7,1	152	443	7,1	229	597	7,1	229	597		
200	277	219,1	8,2	203	545	8,2	203	545	8,2	305	749	8,2	305	749		
250	325	273,0	9,3	254	649	9,3	254	649	9,3	381	903	9,3	381	903		
300	390	323,9	11,5	305	756	11,5	305	756	11,5	457	1060	11,5	457	1060		
350	420	355,6	8,0	356	858				8,0	533	1212					
400	470	406,4	8,8	406	958				8,8	610	1366					
500	590	508,0	9,5	508	1162				9,5	762	1670					

*PN 40 flange connection possible on request.
Materials data stated for basic units.

SWIVEL JOINT TYPE DG-02S

DN 20 – DN 150



STRUCTURE / DESIGN

- stator (outer part) and rotor (inner part) joined by a two-row ball bearing
- for-life lubrication provided in the factory
- welded connection parts: welding ends, pipe bends or flanges

	Materials	
Basic unit	1.7225	1.4571
Welding end	1.0305	1.4571
Flange	1.0460	1.4571

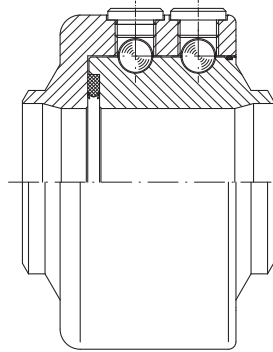

Type DG-02S basic unit
with two-row ball bearing

	Dimensions
Standard:	DN 20 bis DN 150
Flanges:	PN 10/40 to EN 1092
Others:	possible to ANSI (ASA), BS etc.
Welding end:	to ISO recommendations

STANDARD SEALINGS

- PTFE compound sealings

SPECIAL SEALINGS

- additional inner sealing for heavily polluted media
- hermetic radial sealing for underwater applications (from DN 65)
- medium sealings for oxygen, steam and food products

Pressure rating

- PN 16, PN 40 (1.7225) with flanges
- PN 250, PN 350 (1.7225) with welding ends
- PN 16, PN 40 (1.4571) with flanges
- PN 100 (1.4571) with welding ends
- higher pressures possible to max. PN 420

Surface protection

- Gas nitration
- Corrosion-protection primer

NOTE

General technical instructions must be observed. Subject to technical alterations and fluctuations caused by the production process.

Number of revolutions for swivel and rotation movements ≤ 10 rpm.

Swivel movements in several planes see catalogue page 160.

Sets of sealings and balls available individually as spare parts.

APPLICATIONS

- robust design for liquid or gaseous media at high temperatures and particularly high pressures
- ideal for loads with high bending moments
- for slow swivel and rotation movements through 360°
- for rough operating conditions
 - in hydraulic flow pipes
 - at roll stands
 - in sewage plant
 - in steel mills
 - at hose drums
- for installation in flexible pipeline systems, for conveying media from a fixed point to any required flexible point
 - filling systems
 - loading and swivel arms
 - pipe joint shears
- use at test facilities
- special designs suitable for food products

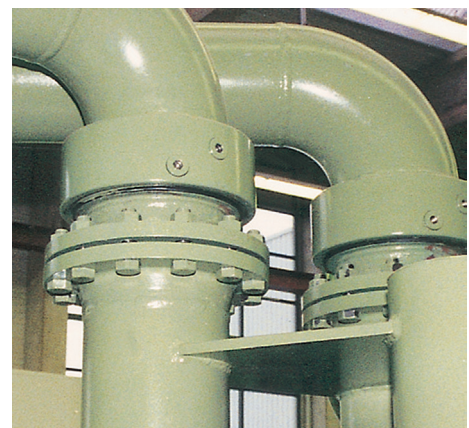

STENFLEX® Swivel Joints type DG-02S
installed at loading arms

Form 11 F flange connection		DN	Ø D ₁ mm	1.7225/PN 16		1.7225/PN 40		1.4571/PN 16		1.4571/PN 40	
				Ø D mm	L mm	Ø D mm	L mm	Ø D mm	L mm	Ø D mm	L mm
		20	72	105	174	105	174	105	174	105	174
25	78	115	174	115	174	115	174	115	174	115	174
32	88	140	178	140	178	140	178	140	178	140	178
40	104	150	184	150	184	150	184	150	184	150	184
50	118	165	194	165	200	165	194	165	194	165	200
65	133	185	204	185	218	185	204	185	204	185	218
80	139	200	214	200	230	200	214	200	214	200	230
100	175	220	218	235	244	220	218	235	244	220	218
125	218	250	254	270	280	250	254	270	280	250	254

Form 11 S welding ends		DN	Ø D ₁ mm	Ø d _a mm	1.7225/PN 250		1.7225/PN 350		1.4571/PN 100	
					s mm	L ₄ mm	s mm	L ₄ mm	s mm	L ₄ mm
		20	72	26.9	3.9	194	3.9	194	3.9	194
25	78	33.7	4.6	194	4.6	194	4.6	194	4.6	194
32	88	42.4	4.9	194	4.9	194	4.9	194	4.9	194
40	104	48.3	5.1	194	5.1	194	5.1	194	5.1	194
50	118	60.3	5.5	204	5.5	204	5.5	204	5.5	204
65	133	73.0	7.0	214	7.0	214	7.0	214	7.0	214
80	139	88.9	7.6	214	7.6	214	7.6	214	7.6	214
100	175	114.3	8.6	214	8.6	214	8.6	214	8.6	214
125	218	141.3	9.5	244	9.5	244	9.5	244	9.5	244

Form 12 F flange connection		DN	Ø D ₁ mm	1.7225/PN 16			1.7225/PN 40			1.4571/PN 16			1.4571/PN 40		
				Ø D mm	L ₂ mm	L ₃ mm	Ø D mm	L ₂ mm	L ₃ mm	Ø D mm	L ₂ mm	L ₃ mm	Ø D mm	L ₂ mm	L ₃ mm
		20	72	105	159	67	105	159	67	105	172	80	105	163	71
25	78	115	159	67	115	159	67	115	172	80	115	172	80		
32	88	140	168	76	140	168	76	140	184	92	140	184	92		
40	104	150	177	85	150	177	85	150	196	104	150	196	104		
50	118	165	200	98	165	203	101	165	225	123	165	228	126		
65	133	185	222	110	185	229	117	185	254	142	185	261	149		
80	139	200	240	128	200	248	136	200	278	166	200	286	174		
100	175	220	268	156	235	281	169	220	318	206	235	331	219		
125	218	250	326	184	270	339	197	250	389	247	270	402	260		

Form 12 S welding ends		DN	Ø D ₁ mm	Ø d _a mm	1.7225/PN 250			1.7225/PN 350			1.4571/PN 100		
					s mm	L ₅ mm	L ₆ mm	s mm	L ₅ mm	L ₆ mm	s mm	L ₅ mm	L ₆ mm
		20	72	26.9	3.9	169	25	3.9	169	25	3.9	173	29
25	78	33.7	4.6	169	25	4.6	169	25	4.6	182	38		
32	88	42.4	4.9	176	32	4.9	176	32	4.9	192	48		
40	104	48.3	5.1	182	38	5.1	182	38	5.1	201	57		
50	118	60.3	5.5	205	51	5.5	205	51	5.5	230	76		
65	133	73.0	7.0	227	63	7.0	227	63	7.0	259	95		
80	139	88.9	7.6	240	76	7.6	240	76	7.6	278	114		
100	175	114.3	8.6	266	102	8.6	266	102	8.6	316	152		
125	218	141.3	9.5	321	127	9.5	321	127	9.5	384	190		

Form 13 F flange connection		DN	Ø D ₁ mm	1.7225/PN 16			1.7225/PN 40			1.4571/PN 16			1.4571/PN 40		
				Ø D mm	L ₁ mm	L ₃ mm	Ø D mm	L ₁ mm	L ₃ mm	Ø D mm	L ₁ mm	L ₃ mm	Ø D mm	L ₁ mm	L ₃ mm
		20	72	105	144	67	105	144	67	105	170	80	105	152	71
25	78	115	144	67	115	144	67	115	170	80	115	170	80		
32	88	140	158	76	140	158	76	140	190	92	140	190	92		
40	104	150	170	85	150	170	85	150	208	104	150	208	104		
50	118	165	206	98	165	206	101	165	256	123	165	256	126		
65	133	185	240	110	185	240	117	185	304	142	185	304	149		
80	139	200	266	128	200	266	136	200	342	166	200	342	174		
100	175	220	318	156	235	318	169	220	418	206	235	418	219		
125	218	250	398	184	270	398	197	250	524	247	270	524	260		

Form 13 S welding ends		DN	Ø D ₁ mm	Ø d _a mm	1.7225/PN 250			1.7225/PN 350			1.4571/PN 100		
					s mm	L ₆ mm	L ₇ mm	s mm	L ₆ mm	L ₇ mm	s mm	L ₆ mm	L ₇ mm
		20	72	26.9	3.9	25	144	3.9	25	144	3.9	29	152
25	78	33.7	4.6	25	144	4.6	25	144	4.6	38	170		
32	88	42.4	4.9	32	158	4.9	32	158	4.9	48	190		
40	104	48.3	5.1	38	170	5.1	38	170	5.1	57	208		
50	118	60.3	5.5	51	206	5.5	51	206	5.5	76	256		
65	133	73.0	7.0	63	240	7.0	63	240	7.0	95	304		
80	139	88.9	7.6	76	266	7.6	76	266	7.6	114	342		
100	175	114.3	8.6	102	318	8.6	102	318	8.6	152	418		
125	218	141.3	9.5	127	398	9.5	127	398	9.5	190	524		

Materials data stated for basic x. Larger sizes up to DN 300 possible on request.

SWIVEL JOINT TYPE DK-01 (ROTATING HEAD JOINT)

DN 8 – DN 50



STRUCTURE

- stator (outer part) and rotor (inner part) joined by a single-row ball bearing
- for-life lubrication provided in the factory
- female thread according to ISO 7-1 (DIN 2999)

Basic unit with threaded connection	Materials	
	1.7225	1.4571

STANDARD SEALINGS

- PTFE compound sealings

SPECIAL SEALINGS

- additional inner sealing for heavily polluted media
- medium sealings for oxygen, steam and food products

Pressure rating

- PN 100 (1.7225)
- PN 40 (1.4571)

Surface protection

- Gas nitration
- Corrosion-protection primer

NOTE

General technical instructions must be observed. Subject to technical alterations and fluctuations caused by the production process.

Number of revolutions for swivel and rotation movements ≤ 10 rpm.

Swivel movements in several planes see catalogue page 160.

Sets of sealings and balls available individually as spare parts.

APPLICATIONS

- for liquid or gaseous media at high temperatures and pressures
- for slow swivel and rotation movements through 360°
- fast installation with threaded connection
- for rough operating conditions
 - in hydraulic flow pipes
 - at roll stands
 - at hose drums
- for installation in flexible pipeline systems, for conveying media from a fixed point to any required flexible point
 - filling systems
 - loading and swivel arms
 - pipe joint shears
- use at test facilities
- special designs suitable for food products

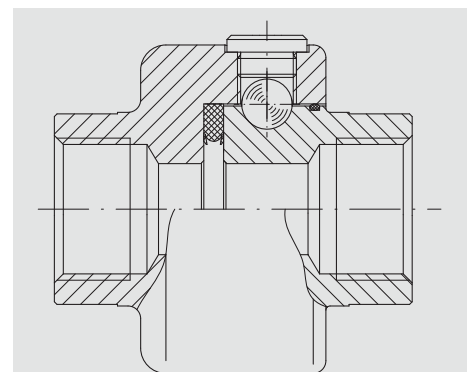

Type DK-01
with one-row ball bearing

Form 11IG threaded connection			DN	Ø d _G inch	i mm	Ø D _K mm	S _w mm	L mm	Weight approx. kg
				8	Rp 1/4"	12	72	32	78
			10	Rp 3/8"	12	72	32	78	1.2
			15	Rp 1/2"	14	72	32	78	1.3
			20	Rp 3/4"	16	72	32	78	1.3
			25	Rp 1"	18	78	41	85	1.6
			32	Rp 1 1/4"	20	88	55	85	2.2
			40	Rp 1 1/2"	22	96	60	90	2.2
			50	Rp 2"	24	118	70	100	4.1

Form 12IG threaded connection			DN	Ø d _G inch	i mm	Ø D _K mm	S _w mm	L ₁ mm	L ₂ mm	L ₃ mm	Weight approx. kg
				8	Rp 1/4"	12	72	32	92	75	30
			10	Rp 3/8"	12	72	32	92	75	30	1.85
			15	Rp 1/2"	14	72	32	92	75	30	1.9
			20	Rp 3/4"	16	72	32	92	75	30	2.0
			25	Rp 1"	18	78	41	107	85	32	2.6
			32	Rp 1 1/4"	20	88	55	115	90	33	3.5
			40	Rp 1 1/2"	22	96	60	132	100	35	4.3
			50	Rp 2"	24	118	70	150	110	42	7.4

Form 13IG threaded connection			DN	Ø d _G inch	i mm	Ø D _K mm	S _w mm	L ₃ mm	L ₄ mm	L ₅ mm	Weight approx. kg
				8	Rp 1/4"	12	72	30	92	110	75
			10	Rp 3/8"	12	72	30	92	110	75	2.6
			15	Rp 1/2"	14	72	30	92	110	75	2.7
			20	Rp 3/4"	16	72	30	92	110	75	2.8
			25	Rp 1"	18	80	32	107	130	85	3.8
			32	Rp 1 1/4"	20	88	33	115	152	100	5.8
			40	Rp 1 1/2"	22	96	35	132	175	110	6.4
			50	Rp 2"	24	118	42	150	208	128	11.5

SWIVEL JOINT TYPE DK-02 (ROTATING HEAD JOINT)

DN 8 – DN 50



STRUCTURE

- stator (outer part) and rotor (inner part) joined by a two-row ball bearing
- for-life lubrication provided in the factory
- female thread according to ISO 7-1 (DIN 2999)

	Materials	
Basic unit with threaded connection	1.7225	1.4571

STANDARD SEALINGS

- PTFE compound sealings

SPECIAL SEALINGS

- additional inner sealing for heavily polluted media
- medium sealings for oxygen, steam and food products

Pressure rating

PN 250, PN 350 (1.7225), PN 420 on request

PN 100 (1.4571)

Surface protection

- Gas nitration
- Corrosion-protection primer

NOTE

General technical instructions must be observed. Subject to technical alterations and fluctuations caused by the production process.

Number of revolutions for swivel and rotation movements ≤ 10 rpm.

Swivel movements in several planes see catalogue page 160.

Sets of sealings and balls available individually as spare parts.

APPLICATIONS

- for liquid or gaseous media at high temperatures and pressures
- suitable for loads with high bending moments
- for slow swivel and rotation movements through 360°
- fast installation with threaded connection
- for rough operating conditions
 - in hydraulic flow pipes
 - at roll stands
 - at hose drums
- for installation in flexible pipeline systems, for conveying media from a fixed point to any required flexible point
 - filling systems
 - loading and swivel arms
 - pipe joint shears
- use at test facilities
- special designs suitable for food products

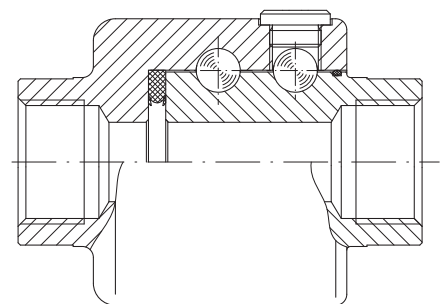

Type DK-02
with two-row ball bearing

Form 11IG threaded connection			DN	Ø d _G inch	i mm	Ø D _K mm	S _w mm	L mm	Weight approx. kg
				8	Rp 1/4"	12	72	32	110
			10	Rp 3/8"	12	72	32	110	2.7
			15	Rp 1/2"	14	72	32	110	2.8
			20	Rp 3/4"	16	72	32	110	2.8
			25	Rp 1"	18	78	41	110	2.9
			32	Rp 1 1/4"	20	88	55	120	3.8
			40	Rp 1 1/2"	22	104	60	120	3.9
			50	Rp 2"	24	118	70	145	5.4

Form 12IG threaded connection			DN	Ø d _G inch	i mm	Ø D _K mm	S _w mm	L ₁ mm	L ₂ mm	L ₃ mm	Weight approx. kg
				8	Rp 1/4"	12	72	32	132	110	30
			10	Rp 3/8"	12	72	32	132	110	30	3.7
			15	Rp 1/2"	14	72	32	132	110	30	3.8
			20	Rp 3/4"	16	72	32	132	110	30	3.8
			25	Rp 1"	18	78	41	132	110	32	3.9
			32	Rp 1 1/4"	20	88	55	158	125	34	6.5
			40	Rp 1 1/2"	22	104	60	158	125	40	6.6
			50	Rp 2"	24	118	70	190	150	40	9.0

Form 13IG threaded connection			DN	Ø d _G inch	i mm	Ø D _K mm	L ₃ mm	L ₄ mm	L ₅ mm	Weight approx. kg
				8	Rp 1/4"	12	72	30	154	110
			10	Rp 3/8"	12	72	30	154	110	5.0
			15	Rp 1/2"	14	72	30	154	110	5.1
			20	Rp 3/4"	16	72	30	154	110	5.1
			25	Rp 1"	18	78	32	160	115	5.2
			32	Rp 1 1/4"	20	88	34	200	132	9.3
			40	Rp 1 1/2"	22	104	40	200	132	9.5
			50	Rp 2"	24	118	40	235	155	11.9

RUBBER-METAL ELEMENTS PROGRAMME OVERVIEW

STENFLEX® **RUBBER-METAL ELEMENTS** ARE USED AS ABSORBERS ON MACHINERY, MEASURING INSTRUMENTS, MOTORS & ENGINES, PUMPS AND INDUSTRIAL EQUIPMENT. THEY PREVENT THE TRANSMISSION OF VIBRATION AND NOISE, THEREBY ENSURING OPTIMUM INSULATION OF STRUCTURE-BORNE SOUND.

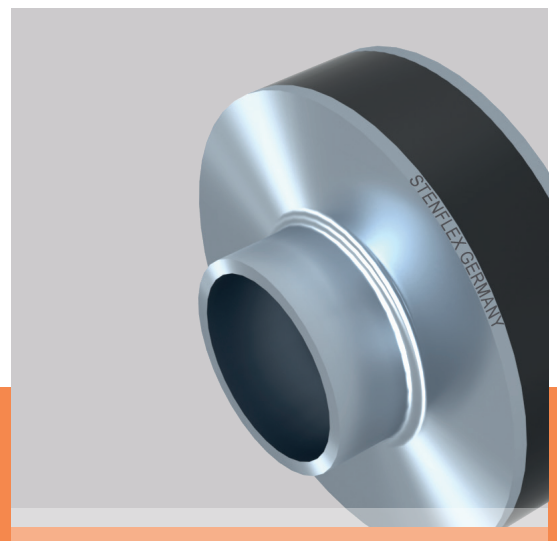
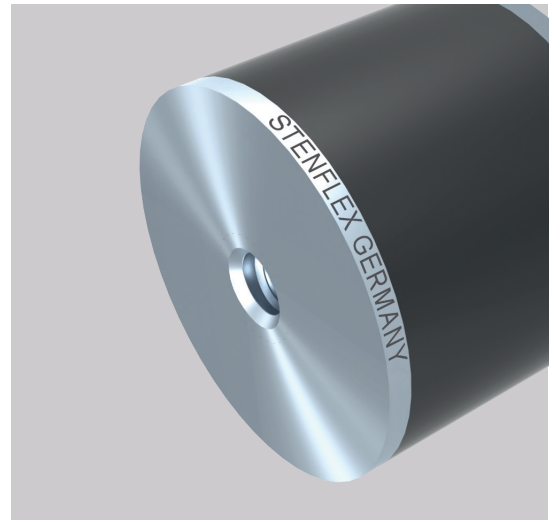

QUALITY.

RUBBER-METAL ELEMENTS

GENERAL DESCRIPTION OF RUBBER-METAL ELEMENTS

STENFLEX® rubber-metal elements have served with distinction for decades as anti-vibration elements in machine construction, engine manufacture and plant construction. Large-scale industrial manufacture in line with EN ISO 9001:2015, coupled with many years of experience in the development and production of rubber-metal elements guarantee our consistently high standard of output quality. Our products are used in a wide variety of applications and ensure trouble-free on-site operation.

For optimum insulation of structure borne sound we recommend mounting appliances, machinery etc., on anti-vibration elements. This solution is a sensible addition to fitting pipes with sound-absorbing rubber expansion joints. Our highly qualified engineers are always ready to assist our customers in matters of technical consultation and to rate component elements.

PURPOSE

- The natural properties of rubber are ideally suited to dampen vibration.
- STENFLEX® rubber-metal elements are used as bearings to absorb
 - vibration
 - shaking
- or for muffling sound at
 - machines
 - measuring equipment
 - engines
 - pumps
 - appliances
 - rollers, etc.

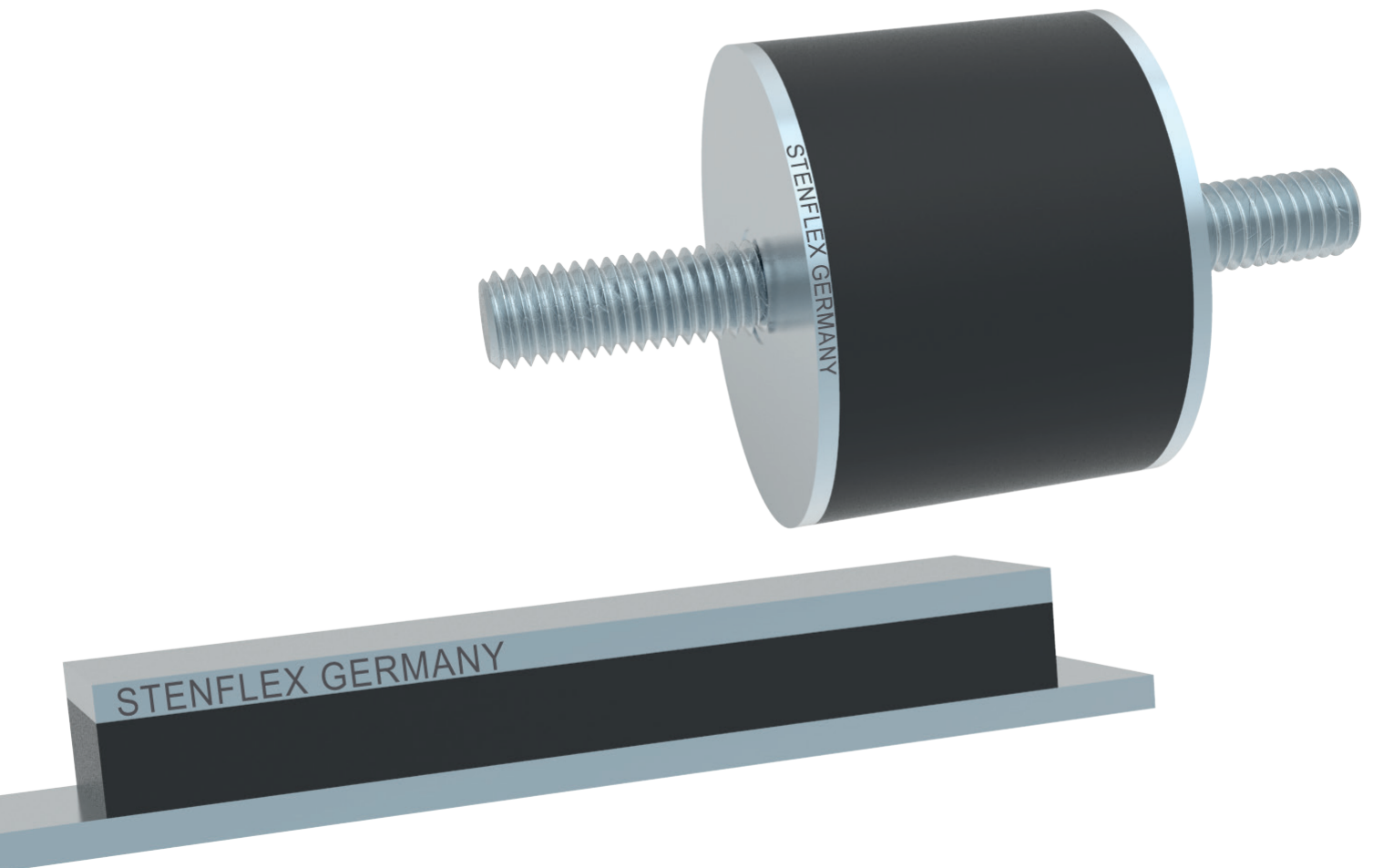

DEVELOPMENT / DESIGN / RATING

STENFLEX® rubber-metal elements are rated theoretically using state-of-the-art computing techniques and optimized under experimental and practical conditions.

Every elastically mounted machine loses equilibrium and vibrates when jolted or impacted. This system vibrates in a certain rhythm with a constant number of vibrations per time unit (natural frequency). If the elastically mounted machine is also subject to a periodic force, the system vibrates with forced vibrations (exciter frequency). Both factors are very important in elastic mounting as indicated by the curve shown in diagram A.

This indicates that vibration insulation is only given if the exciter frequency n_{err} is sufficiently superior to the natural frequency n_e . In any case the sympathetic resonance range must be passed through, i.e., the range in which exciter frequency and natural frequency become identical. Passing through the sympathetic resonance range must occur as quickly as possible. Otherwise vibrations can magnify each other, theoretically, to infinitely large amplitudes. The material attenuation in rubber-metal elements prevents the amplitude from rising above and beyond a certain level.

In the interest of effective elastic bearing, the bearing system must be adequately super-critical for both active and passive interference suppression.

We recommend a ratio of $n_{err} : n_e$ of at least 2 : 1 to guarantee an insulation degree of at least 60 %.

The spring constant C of the rubber- metal elements is indicated in the individual data sheets as C_D for purely compressive stress and as C_S for shearing stress.

For the sake of simplicity, the degrees of insulation can be read in percentages from diagram B without the need to calculate the natural frequency, given a certain exciter frequency and the static sag.

The values F_{tol} stated in the following data tables for rubber-metal elements indicate the tolerable permanent static loads onto which alternating dynamic loads can be superimposed. These values indicate approximate static load only. Where extremely high dynamic alternating loads or high frequencies occur, load data should be reduced accordingly.

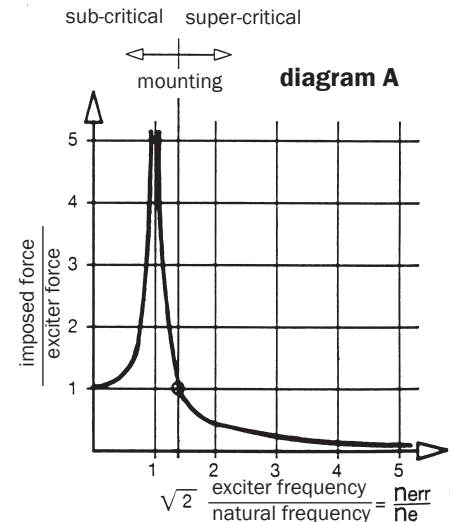

NATURAL FREQUENCY

$$n_e = \frac{300}{\sqrt{f}}$$

f = static sag

n_e = natural frequency (1/min).

DEGREE OF INSULATION

$$\eta = \frac{\left(\frac{n_{err}}{n_e}\right)^2 - 2}{\left(\frac{n_{err}}{n_e}\right)^2 - 1} \cdot 100$$

η = degree of insulation (%)

n_{err} = exciter frequency (1/min)

diagram B

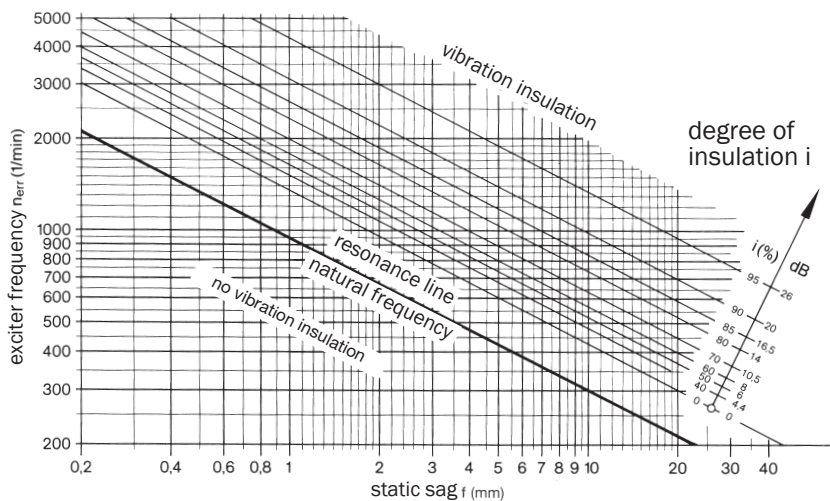

RUBBER-METAL ELEMENTS

GENERAL DESCRIPTION OF RUBBER-METAL ELEMENTS

DEVELOPMENT / DESIGN / RATING

In most cases the machine bearing must take differing spring rates into account in the various load directions.

The directions of the applying force and deformations are called x, y and z for unequivocal definition.

Accordingly, the spring rates for the corresponding directions are called c_x , c_y and c_z .

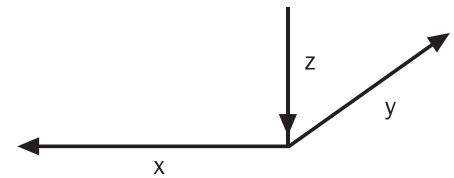

SPRING RATE

$$C = \frac{P}{f}$$

- C = spring rate (N/mm)
- P = force (N)
- f = static sag of the spring element (mm)

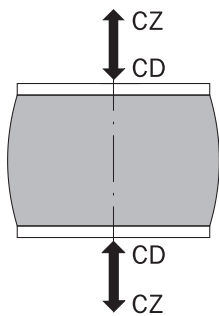

For vertical force introduction
Compressive stress, Tensile stress

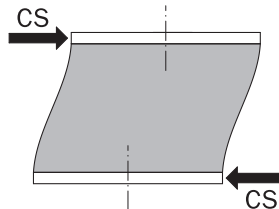

For lateral force introduction
Shearing stress

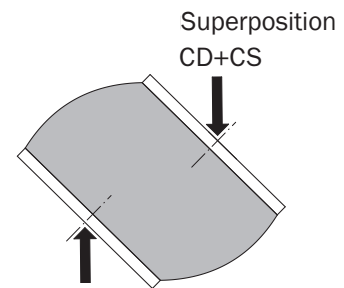

Superposition
CD+CS

For oblique force introduction
Superimposed compressive/shearing stress

CD = spring rate - compressive stress (N/mm)

CZ = spring rate - tensile stress (N/mm)

CS = spring rate - shearing stress (N/mm)

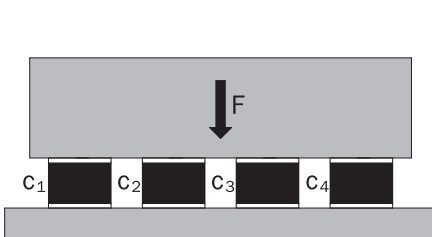

Spring excursion: $s = \frac{F}{c_{totx}} = \frac{F}{c_1 + c_2 + c_3 + c_4}$

Spring rate: $c_{totx} = c_1 + c_2 + c_3 + c_4$

Parallel arrangement

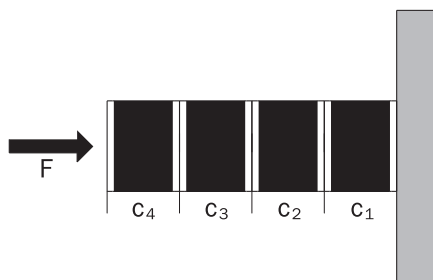

Spring excursion: $s = \frac{F}{c_{totx}} = \frac{F}{c_1} + \frac{F}{c_2} + \frac{F}{c_3} + \frac{F}{c_4}$

Spring rate: $\frac{1}{c_{totx}} = \frac{1}{c_1} + \frac{1}{c_2} + \frac{1}{c_3} + \frac{1}{c_4}$

Successive arrangement

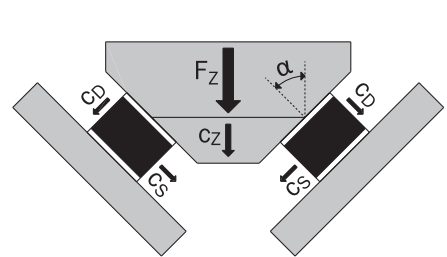

Spring excursion: $s = \frac{F_z}{c_z}$

Spring rate: $c_z = 2 \cdot (c_D \cos^2 \alpha + c_S \sin^2 \alpha)$

Superimposed stress

RUBBER-METAL ELEMENTS

DEFINITIONS

ATTENUATION (DAMPING)

Attenuation corresponds to the energy loss per vibration. In vibration technology, the mechanical loss angle is used as a measure of attenuation.

Attenuation is not a constant value. It depends on

- rubber grade
- temperature
- deformation speed
- shape
- kind of tension

In general, weakly attenuating compounds are used for vibration damping because they achieve a better insulating effect in the super-critical bearing range.

To attain good fatigue strength under compressive stress, generally static spring deflection of 10% – 15% of the original rubber height is allowed.

ELASTICITY

Elasticity behaviour varies from one type of rubber to another.

Elasticity is stated as 'rebound re-silience' as a percentage (DIN 53512). High elasticity corresponds with low attenuation.

OZONE RESISTANCE

Ozone resistance is an important property which is also the basis for weathering resistance (ISO 1431).

Ozone is modified oxygen which occurs in varying concentrations in the atmosphere. Ozone can cause cracking in stretched rubber, running crosswise to the direction of tension. Before ozone cracking can occur the rubber must have exceeded a certain tension or extension limit. This is generally referred to as critical extension. The speed and extent of such damage depends on the exposure conditions and, to a great extent, on the rubber mixture itself.

PROCESSING

After vulcanization rubber parts can be processed by grinding, cutting or puncturing, punching and also drilling. Please ensure that as little heat as possible is introduced to the adhesion zones.

DEFORMATION

Permanent deformation under load is unavoidable in rubber elements. Individual molecule chains 'slide off' each other under static load. This is referred to as 'flow' or 'creeping' (DIN EN ISO 899-1).

Under dynamic load the term used is 'settlement'. This permanent deformation is proportional to the logarithm of time and dependent on temperature; it is stated as a percentage of static spring deflection. Permanent deformation of around 25% is normal.

Elements of natural rubber usually behave much more favourably in terms of permanent deformation than comparable synthetic rubber elements.

HARDNESS

This refers to the relative resistance of the surface to the impressions of a penetrating body of certain dimensions under a certain load.

The hardness coefficients indicate either penetration depth or appropriate fractions derived from this, such as Shore hardness (ISO 868).

ADHESION

Two-ply adhesion primer systems are mainly used to bond the elastomers to the metal.

This system offers good adhesion and effective protection against subversive rust. The adhesion primers are applied to the clean, grease-free bonding surface (following mechanical and/or chemical pre-treatment) such as brushing, dipping or spraying. The vulcanization process then creates a permanent bond between the rubber mixture and the metal.

The resulting adhesion properties normally exceed the breaking strength of the elastomers being used.

Absolute tearing values are dependent on the strength of the rubber mixture and on the geometry or shape of the item. The finished parts can be subsequently galvanized without impairing the adhesive bond.

TOLERANCES

Dimensional tolerances refer to the pertinent DIN standards. Rubber dimensional tolerances are stipulated in DIN 7715.

The same applies to the material properties of the rubber elements. Hardness can fluctuate by ± 5 Shore points. The tolerance range for the spring rate is $\pm 20\%$.

It is possible to reduce the tolerance range for spring rate to $\pm 10\%$, to meet tough technical requirements. The procedure, however, is complex.

RUBBER-METAL ELEMENTS

GENERAL DESCRIPTION OF RUBBER-METAL ELEMENTS

VERSIONS

Rubber-metal elements vary according to the following criteria:

- Type (buffer, rail, ceiling elements, machine feet, bearing elements)
- Kind of connection (male thread, female thread, drilled mounting holes)
- Shore hardness (45, 60, 70 Shore A)
- Stress (compressive, shearing, simultaneous)

The rubber-metal elements are delivered ready for installation. Together with the standard versions featured in the catalogues special versions, designed and developed to operate under special conditions can be produced on request.

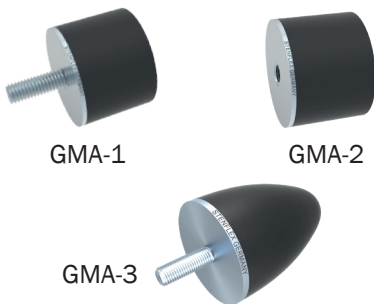

Stopper buffers

Structure:

Cylindrical or parabolic rubber buffers with highly progressive curve. Metal plate vulcanized onto one side, with threaded bolt (male thread) or with female thread.

Stress:

Compressive stress in axial direction. To absorb shock and impact force (limits spring excursion)

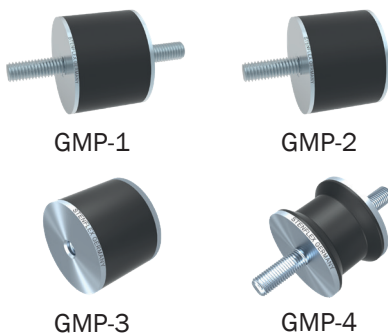

Buffer elements

Structure:

Cylindrical rubber buffers or buffers with retracted rubber edge. Metal plate vulcanized onto one or both sides with threaded bolt (male thread) or with female thread.

Stress:

Compressive and tensile stress in the axial direction. Shearing stress in lateral direction. To absorb shock and acceleration force.



GMD-1

Ceiling elements

Structure:

Elastic hollow profile rubber body with safety bar. Threaded bolt vulcanized onto one side (male thread). U-metal profile drilled through for securing to the ceiling.

Stress:

Compressive and tensile stress in axial direction. To absorb shock and acceleration force.



GMS-1



GMS-2

Rails

Structure:

Flat rubber body for high loads. Metal rails vulcanized onto both sides. Drilled mounting holes can be applied to the metal rails, on-site.

Stress:

High compressive and shearing stress in constricted space.



GMF-1



GMF-2

Machine feet

Structure:

Elastic rubber body encapsulated in a metal casing. Steel securing plate vulcanized onto one side (drilled mounting holes). Other side with threaded bolt (male thread) or with female thread.

Stress:

High compressive and tensile movement in axial direction (bottoming). Slight shearing movement in lateral direction.

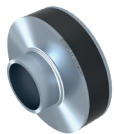

GML-R



GML-U

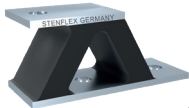

GML-V

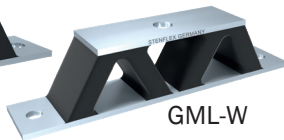

GML-W

Bearing elements

Structure:

Highly elastic ring-shaped, U- or W-shaped rubber bodies. Metal securing plates vulcanized onto both sides, with threaded bolts (male thread) or with drilled mounting holes.

Stress:

Compressive and tensile stress in axial direction. Shearing stress in lateral direction. To absorb shock and acceleration force.

SPECIAL VERSIONS



Rubber-metal machine foot



Rubber-metal cone



Rubber-metal socket

RUBBER-METAL ELEMENTS

GENERAL DESCRIPTION OF RUBBER-METAL ELEMENTS

STRUCTURE

STENFLEX® rubber-metal elements have been optimized by calculation and verified by experimentation to produce highly elastic damping elements with very good adhesion between the rubber and metal components.

MATERIAL QUALITIES

STENFLEX® rubber-metal elements are made of synthetic elastomers. Their wide range of industrial application is covered by combining three standard hardness categories:

- soft = approx. 45 Shore A
- medium = approx. 60 Shore A
- hard = approx. 70 Shore A

Elastomers are basic materials to which sulphur, fillers, plasticizers and ageing protection agents are added to produce rubber compounds suitable for vulcanization. Under the influence of temperature and pressure, the vulcanization process (cross linkage) converts the rubber compounds into rubber grades with their inherent and typical elastic properties.

Material properties such as hardness, elasticity, tensile strength, temperature resistance etc., are rated to the corresponding application. Documents detailing media resistance of the rubber grades are available on request.

Rubber grade	NBR
Trade name	Perbunan
Properties	Quality with excellent oil resistance, very resistant to swelling, e.g. even in contact with petrol/benzole mixture. Temperature resistance in continuous operation -30 °C to + 90 °C.
Applications	Water, gas, fuel oil, mineral oil

CONNECTION PARTS

STENFLEX® rubber-metal elements are supplied ready for installation. They are connected with standard screwed unions. As a rule the elements are equipped with a male or female thread, in accordance with ISO 7-1 (DIN 2999). Some types are drilled through to be fitted with commercially available screws. Rubber-metal rails can be drilled for mounting on-site, as required.

The used metal pieces consist of unalloyed steel, oiled or electrogalvanized.

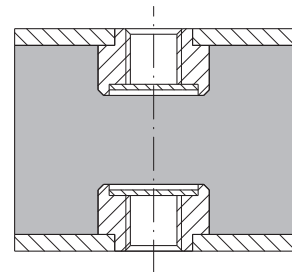

Type GMP-3 with female thread as per ISO 7-1

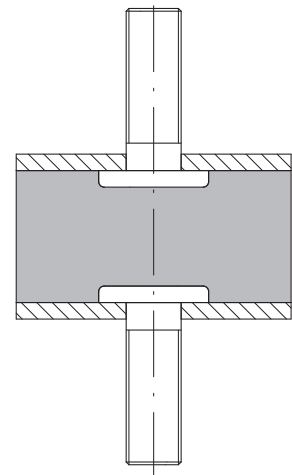

Type GMP-1 with male thread as per ISO 7-1

Material threaded part	Material No. as per DIN EN	Designation as per DIN EN (DIN) or strength class
Unalloyed steel	1.0038	S235JR 5.6, 8.8

RUBBER-METAL ELEMENTS

APPLICATIONS / PROPERTIES /
POSSIBLE USES / INDUSTRIES

STENFLEX® rubber-metal element types		GMA-1/-2	GMA-3	GMP-1/-2/-3	GMP-4	GMS-1/-2	GMF-1/-2	GMLR	GMLU	GMLV/-W	GMD-1/-2
Applications	Shock absorption	■	■	■	■	■	■	■	■	■	■
	Sound and vibration absorption	■	■	■	■	■	■	■			■
	Protection from jarring	■	■	■	■	■	■	■	■	■	■
	Elastic bearing	■	■	■	■	■	■	■	■	■	■
	Compensation for installation inaccuracies	■	■	■	■		■	■			
Properties	Tensile stress				■			■			■
	Compressive stress	■	■	■	■	■	■	■	■	■	■
	Shearing stress			■	■			■		■	
	Compressive/shearing stress	■	■	■	■	■		■			
	High dynamic stress				■						
	Good fatigue strength				■						
Possible uses	Pipelines										■
	Air and gas ducts										■
	Machinery	■	■	■	■	■	■	■	■	■	
	Engines			■	■	■	■	■			
	Pumps			■	■	■	■	■			
	Compressors			■	■		■	■			
	Condensers					■					
	Measuring devices								■	■	
	Axles and vehicle frames	■	■	■	■			■			
Industries	Domestic industry										■
	Heating installation										■
	Ventilation and A/C technology										■
	Mechanical engineering	■	■	■	■	■	■	■	■	■	
	Shipbuilding			■	■	■	■	■			■
	Hydraulic systems			■	■	■	■	■			
	Chemical industry			■	■		■	■			
	Water supply/treatment			■	■		■	■			
	Power industry			■		■		■			
	Plant construction			■	■	■			■	■	■
	Mensuration and control techniques								■	■	
	Construction of vehicles	■	■	■	■			■			

Table showing prime applications, properties, possible uses and industries.

RUBBER-METAL ELEMENTS

PROGRAM SUMMARY

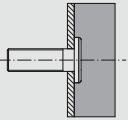
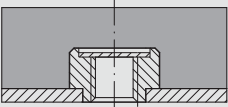
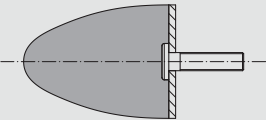
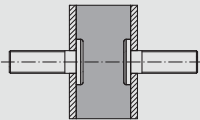
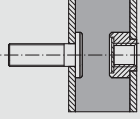
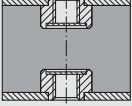
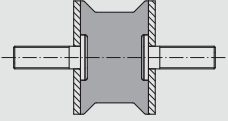
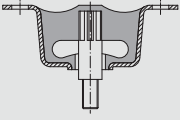
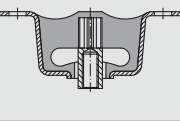
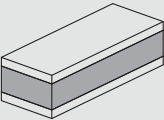
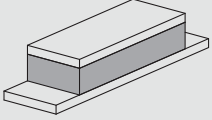
	Type	Dimensions mm	Rubber hardness	Connections	Page	
Anschlagpuffer		GMA-1	Ø 18 - 100	60 Shore A	male thread on one side	184
		GMA-2	Ø 20 - 150	60 Shore A	female thread on one side	184
		GMA-3	Ø 50 - 95	60 Shore A	male thread on one side	185
Buffer elements		GMP-1	Ø 18 - 100	45 Shore A 60 Shore A 70 Shore A	male thread on both sides	186
		GMP-2	Ø 20 - 100	45 Shore A 60 Shore A 70 Shore A	male and female thread	187
		GMP-3	Ø 20 - 200	45 Shore A 60 Shore A 70 Shore A	female thread on both sides	188
		GMP-4	Ø 25 - 80	45 Shore A 60 Shore A 70 Shore A	male thread on both sides	189
Ceiling elements		GMD-1	95 x 32 x 53	45 Shore A 60 Shore A 70 Shore A	drilled mounting holes, male thread	190
		GMD-2	95 x 32 x 38	45 Shore A 60 Shore A 70 Shore A	drilled mounting holes, female thread	190
Rails		GMS-1	width 20 - 150 height 30 - 80 length max. 2000	60 Shore A	female thread or holes, to be drilled on-site	191
		GMS-2	width 50 - 100 height 40 - 60 length 200-480	60 Shore A	female thread or holes, to be drilled on-site	191

RUBBER-METAL ELEMENTS

PROGRAM SUMMARY

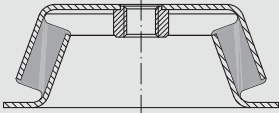
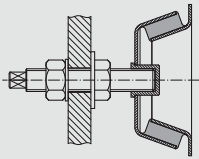
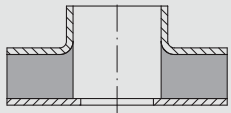
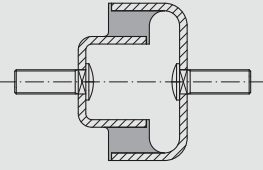
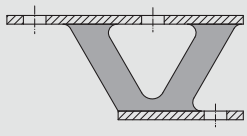
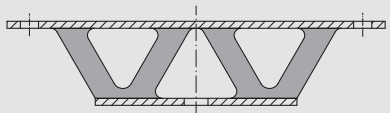
	Type	Dimensions mm	Rubber hardness	Connections	Page	
Machine feet		GMF-1	Ø 57 - 125	45 Shore A 60 Shore A 70 Shore A	drilled mounting holes, female thread	192
		GMF-2	Ø 88 - 125	45 Shore A 60 Shore A 70 Shore A	drilled mounting holes, male thread	192
Bearing elements		GML-R	Ø 36 - 60	45 Shore A 60 Shore A 70 Shore A	drilled mounting holes	193
		GML-U	35 x 52 x 36 50 x 54 x 40	45 Shore A 60 Shore A 70 Shore A	male thread on both sides	194
		GML-V	25 x 67 x 30	45 Shore A 60 Shore A 70 Shore A	drilled mounting holes	195
		GML-W	25 x 135 x 30	45 Shore A 60 Shore A 70 Shore A	drilled mounting holes	195

RUBBER-METAL ELEMENT TYPE GMA-1, GMA-2

STOPPER BUFFER, CYLINDRICAL CROSS SECTION

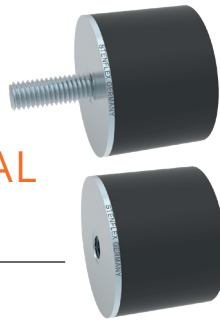

STRUCTURE TYPE GMA-1, GMA-2 METAL PARTS / RUBBER ELEMENT

- **Type GMA-1** one side with threaded bolt (male thread)
- **Type GMA-2** one side with nut thread (female thread)
- Material: 1.0038 (S235JR) / 8.8
- Corrosion protection: oiled or electrogalvanized
- Cylindrical rubber element with metal plate vulcanized onto one side

Rubber grade	NBR
Rubber hardness	medium - 60 Shore A
Possible uses	Water, gas, fuel oil, mineral oil

DIMENSIONS / STRESS TYPE GMA-1

Ø D	H	h	s	G	l	Compressive stress		Art. No..	Pck. qty.
						Spring rate c_z N/mm	Load F_{tol}^* N		
18	7.5	5.5	2	M 6	16.0	350	240	51873300	100
20	13.5	11.5	2	M 6	16.0	150	260	51873400	100
25	17.0	14.0	3	M 6	16.0	180	380	51873500	100
30	17.0	14.0	3	M 8	21.0	360	760	51883900	60
40	27.0	24.0	3	M 8	21.0	270	970	51884000	50
50	21.0	18.0	3	M 10	26.5	650	1760	51884100	20
75	25.0	22.0	3	M 12	39.0	1400	4620	51884200	8
100	40.0	37.0	3	M 16	44.0	1400	7770	51873600	4

DIMENSIONS / STRESS TYPE GMA-2

Ø D	H	h	s	G	l	Compressive stress		Art. No..	Pck. qty.
						Spring rate c_z N/mm	Load F_{tol}^* N		
20	13.5	12.0	1.5	M 6	9.5	220	230	51873700	100
30	17.0	14.0	3.0	M 8	9.5	550	620	51885400	80
40	27.0	24.0	3.0	M 8	9.5	350	920	51873800	40
50	21.0	18.0	3.0	M 10	10.5	700	1100	51885500	20
75	25.0	22.0	3.0	M 12	12.5	1700	3200	51885600	20
100	40.0	37.0	3.0	M 16	16.5	1400	4950	51885700	12
150	75.0	70.0	5.0	M 20	17.5	1350	11650	51873900	4

* F_{tol} is the **tolerable static permanent load**: a dynamic alternating load can be superimposed. The stated tolerable loads are only approximate indications for the static load. Delivery only possible in the stated packaging quantities (far-right column).

NOTE

Please comply with general technical instructions. Subject to technical alterations and deviations resulting from the manufacturing process.

APPLICATIONS

- as shock buffer stopper
- to limit impact in machinery on elastic bearings
- to limit spring excursion in vehicles
- for machines which are not firmly anchored on susceptible flooring
- for damping sound and vibration
- for compressive stress
- for superimposed compressive/shearing stress

VERSIONS

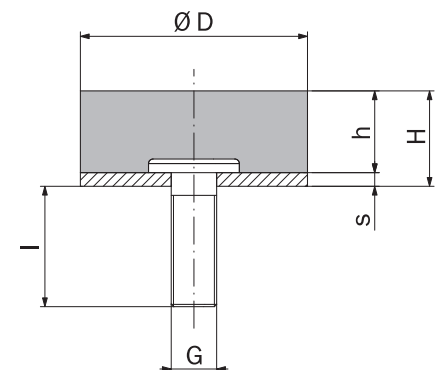

Type GMA-1

One side with male thread

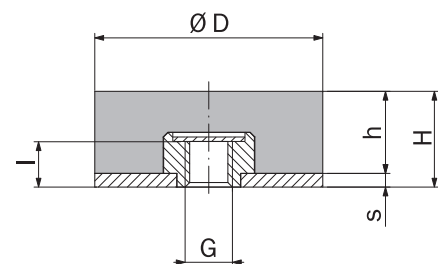

Type GMA-2

One side with female thread

RUBBER-METAL ELEMENT TYPE GMA-3

STOPPER BUFFER, PARABOLIC CROSS SECTION

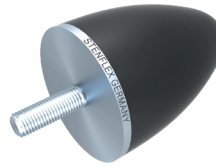

STRUCTURE TYPE GMA-3 METAL PARTS / RUBBER ELEMENT

- Stopper buffer with parabolic cross section and threaded bolt (male thread)
- Material: 1.0038 (S235JR) / 8.8
- Corrosion protection: oiled or electrogalvanized
- Parabolic rubber element with metal plate vulcanized onto one side

Rubber grade	NBR
Rubber hardness	medium – 60 Shore A
Possible uses	Water, gas, fuel oil, mineral oil

DIMENSIONS / STRESS

Ø D	H	G	I	Rubber hardness Shore A	Compressive stress		Art. No.	Pck. qty.
					Spring excursion max. mm	Load F_{tol}^* N		
50	61	M 8	26	60	25	2500	51842300	10
50	67	M 8	36	60	25	1900	51842200	10
95	83	M 16	47	60	30	5000	51842100	10

* F_{tol} is the **tolerable static permanent load**: a dynamic alternating load can be superimposed. The stated tolerable loads are only approximate indications for the static load. Delivery only possible in the stated packaging quantities (far-right column).

NOTE

Please comply with general technical instructions. Subject to technical alterations and deviations resulting from the manufacturing process.

APPLICATIONS

- as shock buffer stopper
- to limit vibration deflection and spring excursion
- for soft absorption of impacts with progressive curves
- for damping sound and vibration
- for compressive stress
- for superimposed compressive/shearing stress

VERSIONS

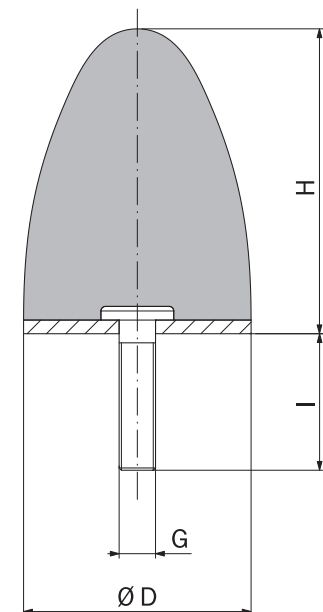

Type GMA-3

One side with male thread

RUBBER-METAL ELEMENT TYPE GMP-1

BUFFER ELEMENT, CYLINDRICAL CROSS SECTION WITH MALE THREAD

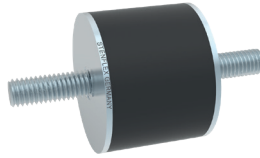

STRUCTURE TYPE GMP-1 METAL PARTS / RUBBER ELEMENT

- Buffer element with threaded bolt (male thread) on both sides
- Material: 1.0038 (S235JR) / 8.8
- Corrosion protection: oiled or electrogalvanized
- Cylindrical rubber element with metal plates vulcanized onto both sides

Rubber grade	NBR	
Rubber hardness	hard	- 70 Shore A
	medium	- 60 Shore A
	soft	- 45 Shore A
Possible uses	Water, gas, fuel oil, mineral oil	

DIMENSIONS / STRESS

Ø D	H	h	s	G	l	Rubber hardness Shore A	Compressive stress		Art. No..	Pck. qty.
							Spring rate c_z N/mm	Load F_{tot}^* N		
18	8.5	4.5	2.0	M 6	11.0	70	800	540	00005938	100
18	8.5	4.5	2.0	M 6	11.0	60	500	340	00005939	100
18	8.5	4.5	2.0	M 6	11.0	45	300	200	00005940	100
18	8.5	4.5	2.0	M 6	16.0	70	800	540	51897600	100
20	15.0	11.0	2.0	M 6	16.0	60	180	300	51875800	100
20	15.0	11.0	2.0	M 6	16.0	45	110	180	51876600	100
25	20.0	14.0	3.0	M 6	16.0	70	350	740	51875100	60
25	20.0	14.0	3.0	M 6	16.0	60	220	460	51875900	60
25	20.0	14.0	3.0	M 6	16.0	45	130	270	51876700	60
30	15.0	10.0	2.5	M 8	21.0	60	590	880	51897700	60
30	20.0	14.0	3.0	M 8	21.0	70	570	1190	51875200	60
30	20.0	14.0	3.0	M 8	21.0	60	360	750	51876000	60
30	20.0	14.0	3.0	M 8	21.0	45	210	440	51876800	60
30	30.0	24.0	3.0	M 8	20.0	60	160	580	51897800	60
30	30.0	24.0	3.0	M 8	20.0	45	90	340	51898700	60
40	30.0	24.0	3.0	M 8	21.0	60	320	1150	51876100	20
40	40.0	34.0	3.0	M 8	21.0	70	320	1620	51875400	20
40	40.0	34.0	3.0	M 8	21.0	60	200	1020	51876200	20
50	20.0	14.0	3.0	M 10	18.5	70	2430	5100	51897000	12
50	20.0	14.0	3.0	M 10	18.5	60	1520	3190	51897900	12
50	20.0	14.0	3.0	M 10	18.5	45	890	1880	51898800	12
50	24.0	18.0	3.0	M 10	26.5	70	1490	4020	51897100	12
50	24.0	18.0	3.0	M 10	26.5	60	930	2510	51898000	12
50	30.0	24.0	3.0	M 10	26.5	70	900	3220	51875500	12
50	30.0	24.0	3.0	M 10	26.5	60	550	2010	51876300	12
50	30.0	24.0	3.0	M 10	26.5	45	330	1180	51877100	12
50	40.0	34.0	3.0	M 10	26.5	70	540	2770	51897200	12
50	40.0	34.0	3.0	M 10	26.5	60	340	1730	51898100	12
50	45.0	39.0	3.0	M 10	26.5	60	270	1580	51898200	12
50	45.0	39.0	3.0	M 10	26.5	45	160	930	51899100	12
75	55.0	49.0	3.0	M 12	39.0	70	640	4700	51897400	4
75	55.0	49.0	3.0	M 12	39.0	60	400	2940	51898300	4
75	55.0	49.0	3.0	M 12	39.0	45	235	1730	51899200	4
100	30.0	24.0	3.0	M 16	44.0	70	6160	22170	51897500	4
100	30.0	24.0	3.0	M 16	44.0	60	3850	13860	51898400	4
100	60.0	54.0	3.0	M 16	44.0	70	1360	11020	51875700	4
100	60.0	54.0	3.0	M 16	44.0	60	850	6890	51876500	4
100	60.0	54.0	3.0	M 16	44.0	45	500	4050	51877300	4

NOTE

Please comply with general technical instructions. Subject to technical alterations and deviations resulting from the manufacturing process.

APPLICATIONS

- for simple elastic bearings
- highly versatile in e.g.
 - mechanical engineering
 - electrical industry
- for damping sound and vibration
- for compressive stress
- for shearing stress
- for superimposed compressive/shearing stress

VERSIONS

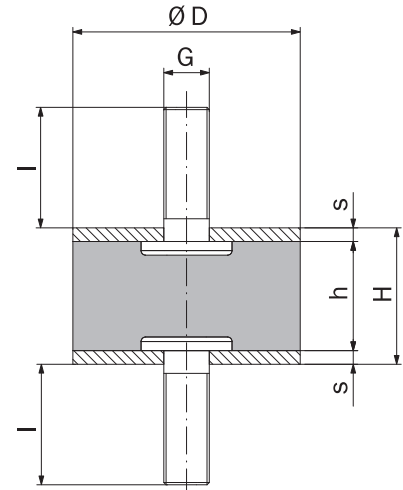

Type GMP-1

Both sides with male thread

* F_{tot} is the **tolerable static permanent load**: a dynamic alternating load can be superimposed. The stated tolerable loads are only approximate indications for the static load.

Delivery only possible in the stated packaging quantities (far-right column).

RUBBER-METAL ELEMENT TYPE GMP-2

BUFFER ELEMENT, CYLINDRICAL CROSS SECTION WITH MALE AND FEMALE THREAD

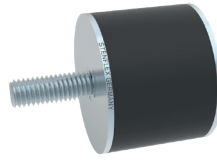

STRUCTURE TYPE GMP-2 METAL PARTS / RUBBER ELEMENT

- Buffer element, one side with threaded bolt (male thread), other side with nut thread (female thread)
- Material: 1.0038 (S235JR) / 8.8
- Corrosion protection: oiled or electrogalvanized
- Cylindrical rubber element with metal plates vulcanized onto both sides

Rubber grade	NBR
Rubber hardness	hard – 70 Shore A medium – 60 Shore A soft – 45 Shore A
Possible uses	Water, gas, fuel oil, mineral oil

DIMENSIONS / STRESS

Ø D	H	h	s	G	l	t	Rubber hard- ness Shore	Compressive stress		Art. No..	Pck. qty.
								Spring rate c _z	Load F _{tot} *		
mm	mm	mm	mm	mm	mm	mm	A	N/mm	N		
20	25	21.5	2/1.5	M 6	16.0	6.5	70	140	290	51870000	100
20	25	21.5	2/1.5	M 6	16.0	6.5	60	80	180	51870500	100
20	25	21.5	2/1.5	M 6	16.0	6.5	45	50	100	51871000	100
25	20	16.5	2/1.5	M 6	11.0	6.6	70	300	470	51870100	80
25	20	16.5	2/1.5	M 6	11.0	6.6	60	140	290	51870600	80
30	20	15.5	2.5/2	M 8	13.0	6.5	45	650	900	51870200	60
30	20	15.5	2.5/2	M 8	13.0	6.5	70	410	560	51870700	60
30	20	15.5	2.5/2	M 8	13.0	6.5	60	240	330	51871200	60
30	20	14.5	2.5/3	M 8	16.0	6.5	45	670	820	00005942	60
30	20	14.5	2.5/3	M 8	16.0	6.5	60	420	510	00005943	60
30	30	24.0	3	M 8	21.0	9.5	70	340	740	51878000	60
30	30	24.0	3	M 8	21.0	9.5	60	210	460	51878700	60
30	30	24.0	3	M 8	21.0	9.5	45	120	270	51879400	60
30	40	34.0	3	M 8	21.0	9.5	60	110	410	51870800	60
30	40	34.0	3	M 8	21.0	9.5	45	60	240	51871300	60
40	30	24.0	3	M 8	21.0	9.5	60	340	740	51870900	40
40	30	24.0	3	M 8	21.0	9.5	70	200	440	51871400	40
50	40	34.0	3	M 10	26.5	10.5	60	550	2000	51878200	20
50	40	34.0	3	M 10	26.5	10.5	70	350	1240	51878900	20
50	40	34.0	3	M 10	26.5	10.5	60	210	730	51879600	20
75	50	44.0	3	M 12	39.0	12.5	45	930	4600	51878400	12
75	50	44.0	3	M 12	39.0	12.5	70	600	2850	51879100	12
75	50	44.0	3	M 12	39.0	12.5	60	310	1680	51879800	12
100	40	34.0	3	M 16	44.0	16.5	70	3100	6700	51879300	4
100	40	34.0	3	M 16	44.0	16.5	60	1600	4200	51878600	4
100	40	34.0	3	M 16	44.0	16.5	45	1000	2500	51880000	4

* F_{tot} is the **tolerable static permanent load**: a dynamic alternating load can be superimposed. The stated tolerable loads are only approximate indications for the static load. Delivery only possible in the stated packaging quantities (far-right column).

NOTE

Please comply with general technical instructions. Subject to technical alterations and deviations resulting from the manufacturing process.

APPLICATIONS

- for simple elastic bearings
- highly versatile in e.g.
 - mechanical engineering
 - electrical industry
- for damping sound and vibration
- for compressive stress
- for shearing stress
- for superimposed compressive/shearing stress

VERSIONS

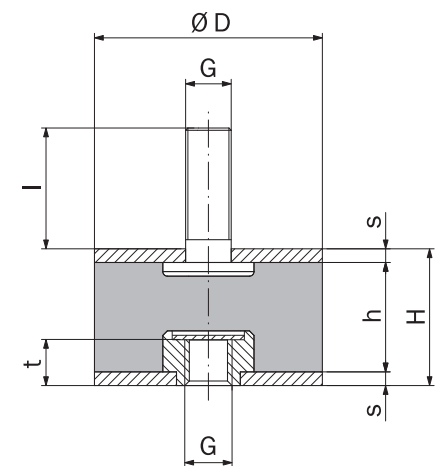

Type GMP-2
With male and female thread

RUBBER-METAL ELEMENT TYPE GMP-3

BUFFER ELEMENT, CYLINDRICAL CROSS SECTION WITH FEMALE THREAD

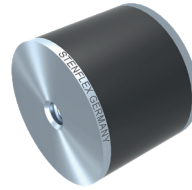

STRUCTURE TYPE GMP-3 METAL PARTS / RUBBER ELEMENT

- Buffer element with nut thread (female thread) on both sides
- Material: 1.0038 (S235JR) / 8.8
- Corrosion protection: oiled or electrogalvanized
- Cylindrical rubber element with metal plates vulcanized onto both sides

Rubber grade	NBR
Rubber hardness	hard - 70 Shore A medium - 60 Shore A soft - 45 Shore A
Possible uses	Water, gas, fuel oil, mineral oil

DIMENSIONS / STRESS

Ø D	H	h	s	G	t	Rubber hardness Shore A	Compressive stress		Art. No..	Pck. qty.
							Spring rate c_z N/mm	Load F_{tol}^* N		
20	25	22	1.5	M 6	6.5	60	120	170	51872000	80
20	25	22	1.5	M 6	6.5	45	70	100	51872500	80
30	30	24	3.0	M 8	9.5	60	360	430	51880900	60
30	30	24	3.0	M 8	9.5	45	210	250	51881300	60
40	30	24	3.0	M 10	9.5	60	550	660	51881000	40
50	30	24	3.0	M 10	10.5	70	1680	1520	51871600	20
50	30	24	3.0	M 10	10.5	60	1050	950	51872100	20
50	30	24	3.0	M 10	10.5	45	620	560	51872600	20
50	40	34	3.0	M 10	10.5	70	660	1570	51880700	20
50	40	34	3.0	M 10	10.5	60	410	980	51881100	20
75	50	44	3.0	M 12	12.5	70	980	3620	51880800	12
75	50	44	3.0	M 12	12.5	60	610	2010	51881200	12
75	50	44	3.0	M 12	12.5	45	360	1180	51881600	12
100	60	54	3.0	M 16	16.5	70	1360	4900	51871700	4
100	60	54	3.0	M 16	16.5	60	850	3060	51872200	4
100	60	54	3.0	M 16	16.5	45	500	1800	51872700	4
150	75	65	5.0	M 20	17.5	60	1630	9050	51872300	4
150	75	65	5.0	M 20	17.5	45	960	5320	51872800	4
200	100	90	5.0	M 20	17.5	60	2030	18880	51872400	4

* F_{tol} is the **tolerable static permanent load**: a dynamic alternating load can be superimposed. The stated tolerable loads are only approximate indications for the static load. Delivery only possible in the stated packaging quantities (far-right column).

NOTE

Please comply with general technical instructions. Subject to technical alterations and deviations resulting from the manufacturing process.

APPLICATIONS

- for simple elastic bearings
- highly versatile in e.g.
 - mechanical engineering
 - electrical industry
- for damping sound and vibration
- for compressive stress
- for shearing stress
- for superimposed compressive/shearing stress

VERSIONS

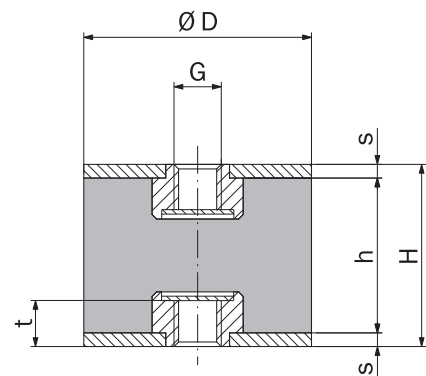

Type GMP-3
With female thread

RUBBER-METAL ELEMENT TYPE GMP-4

BUFFER ELEMENT, CONSTRICTED CYLINDRICAL CROSS SECTION WITH MALE THREAD

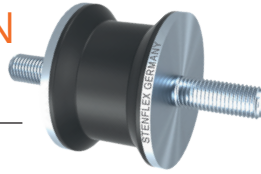

STRUCTURE TYPE GMP-4 METAL PARTS / RUBBER ELEMENT

- Buffer element with threaded bolt (male thread) on both sides
- Material: 1.0038 (S235JR) / 8.8
- Corrosion protection: oiled or electrogalvanized
- Cylindrical rubber element with constricted cross section and metal plates vulcanized onto both sides

Rubber grade	NBR
Rubber hardness	hard – 70 Shore A medium – 60 Shore A soft – 45 Shore A
Possible uses	Water, gas, fuel oil, mineral oil

DIMENSIONS / STRESS

Ø D	Ø d	H	h	s	G	I	Rubber hardness Shore A	Compressive stress		Art. No..	Pck. qty.
								Spring rate c_z	Load F_{tol}^*		
mm	mm	mm	mm	mm	mm	mm		N/mm	N		
25.0	22	22	16	3	M 8	21.0	70	320	770	51873000	60
25.0	22	22	16	3	M 8	21.0	60	200	480	51873100	60
25.0	22	22	16	3	M 8	21.0	45	120	280	51873200	60
40.0	35	28	22	3	M 10	16.5/21.5	60	330	1090	51882900	20
40.0	35	28	22	3	M 10	26.5	70	530	1740	51882000	20
40.0	35	28	22	3	M 10	26.5	60	330	1090	51882300	20
40.0	35	28	22	3	M 10	26.5	45	190	640	51882600	20
55.0	45	36	30	3	M 10	22.0	60	370	1670	00005945	8
60.0	50	60	54	3	M 10	26.5	70	340	2590	51882200	8
60.0	50	60	54	3	M 10	26.5	60	200	1620	51882500	8
60.0	50	60	54	3	M 10	26.5	45	110	950	51882800	8
80.0	70	70	64	4	M 14	37.0	70	540	5220	51882100	8
80.0	70	70	64	4	M 14	37.0	60	340	3260	51882400	8

* F_{tol} is the **tolerable static permanent load**: a dynamic alternating load can be superimposed. The stated tolerable loads are only approximate indications for the static load. Delivery only possible in the stated packaging quantities (far-right column).

NOTE

Please comply with general technical instructions. Subject to technical alterations and deviations resulting from the manufacturing process.

APPLICATIONS

- for high, dynamic peak stresses with good fatigue strength
- highly versatile in e.g.
 - mechanical engineering
 - electrical industry
- for damping sound and vibration
- for compressive stress
- for shearing stress
- for superimposed compressive/shearing stress
- less susceptible to tensile stress than types GMP-1, GMP-2 and GMP-3

VERSIONS

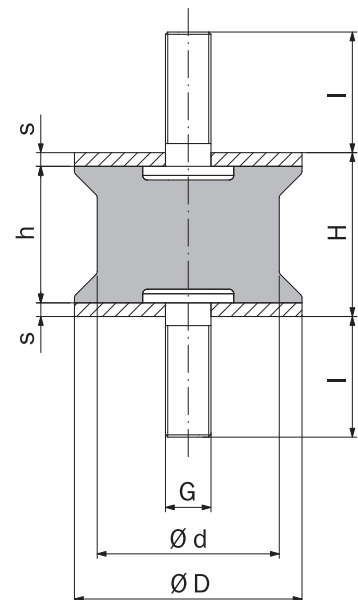

Type GMP-4

Both sides with male thread

RUBBER-METAL ELEMENT TYPE GMD-1, GMD-2

CEILING ELEMENT WITH MALE OR FEMALE THREAD

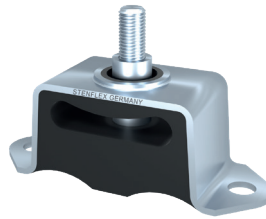

STRUCTURE TYPE GMD-1, GMD-2 METAL PARTS / RUBBER ELEMENT

- **Type GMD-1** with male threaded bolt vulcanized into the rubber
- **Type GMD-2** with female threaded bolt vulcanized into the rubber
- Material: 1.0038 (S235JR) / 8.8
- Corrosion protection: oiled or electrogalvanized
- Very elastic rubber element with safety bar and stopper. Vulcanized U-metal profil.

Rubber grade	NBR
Rubber hardness	hard - 70 Shore A medium - 60 Shore A soft - 45 Shore A
Possible uses	Water, gas, fuel oil, mineral oil

DIMENSIONS / STRESS TYPE GMD-1

A	B	H	I	G	d	Rubber hardness Shore A	Tensile/compressive stress			Art. No.	Pck. qty.
mm	mm	mm	mm	mm	mm		Spring excursion max. mm	Tol. dynamic load N	Tol. static load N		
72	32	38	15	M 8	8.5	70	9	1500	550	51893500	10
72	32	38	15	M 8	8.5	60	9	1000	350	51893600	10
72	32	38	15	M 8	8.5	45	9	600	200	51893700	10

DIMENSIONS / STRESS TYPE GMD-2

A	B	H	I	G	d	Rubber hardness Shore A	Tensile/compressive stress			Art. No.	Pck. qty.
mm	mm	mm	mm	mm	mm		Spring excursion max. mm	Tol. dynamic load N	Tol. static load N		
72	32	38	15	M 8	8.5	70	9	1500	550	51893800	10
72	32	38	15	M 8	8.5	60	9	1000	350	51893900	10
72	32	38	15	M 8	8.5	45	9	600	200	51894000	10

The stated tolerable loads are only approximate indications for the static load. Delivery only possible in the stated packaging quantities (far-right column).

NOTE

Please comply with general technical instructions. Subject to technical alterations and deviations resulting from the manufacturing process.

APPLICATIONS

- ideal for elastic suspension of appliances and pipes from ceilings and walls
- for damping sound and vibration
- for soft absorption of shock and acceleration force
- safe suspension of parts even under extreme impact stress
- for compressive stress
- for tensile stress

VERSIONS

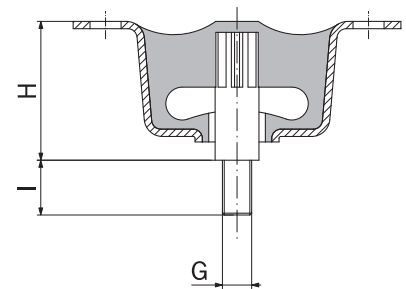

Type GMD-1
With male thread

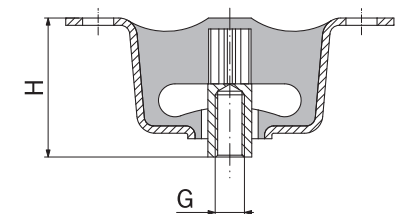

Type GMD-2
With female thread

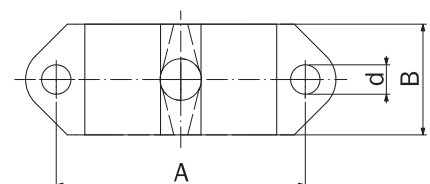

Type GMD-1 und GMD-2
Top view

RUBBER-METAL ELEMENT TYPE GMS-1, GMS-2

RAIL ELEMENT, FLUSH OUTSIDE OR WITH LATERALLY PROTRUDING BASE RAIL

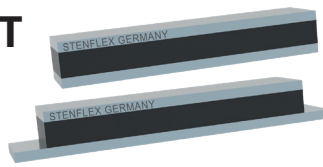

STRUCTURE TYPE GMS-1, GMS-2 METAL PARTS / RUBBER ELEMENT

- **Type GMS-1** with metal rails on both sides
- **Type GMS-2** with metal rails on both sides, protruding on one side
- Drilled mounting holes can be applied to the metal rails, on-site
- Material: 1.0038 (S235JR)
- Corrosion protection: oiled or electrogalvanized
- Rail-shaped rubber element with metal rails as per DIN 1017, vulcanized onto both sides

Rubber grade	NBR
Rubber hardness	medium – 60 Shore A
Possible uses	Water, gas, fuel oil, mineral oil

DIMENSIONS / STRESS TYPE GMS-1

B	H	h	s	L Length max.	Compressive stress Spring rate ref. to L = 100 mm c_z N/mm	Art. No.
mm	mm	mm	mm	mm		
20	30	20	5	500	670	51888100
25	30	20	5	500	920	51888200
40	35	19	8	500	2340	51888300
50	40	20	10	2000	3500	51888000
50	50	30	10	2000	1500	51887300
60	60	40	10	2000	1170	51887500
70	50	30	10	2000	2840	51887600
100	60	30	15	2000	5400	51887800
100	80	50	15	2000	2000	51887900
150	65	35	15	2000	7750	51874600
150	80	50	15	2000	4170	51874700

DIMENSIONS / STRESS TYPE GMS-2

B	H	h	S ₁	S ₂	L	L ₁	Compressive stress Spring rate c_z N/mm	Load F _{Tol} * N	Art. No.
mm	mm	mm	mm	mm	mm	mm			
50	40	20	12	8	200	150	4000	8000	51899400
50	40	20	12	8	270	220	7100	15000	51899500
100	60	30	15	15	480	360	18200	59000	51899600

* F_{Tol} is the **tolerable static permanent load**: a dynamic alternating load can be superimposed. The stated tolerable loads are only approximate indications for the static load.

NOTE

Rails with protruding base plate can be compressed under static load by approx. 10 % – 15 % of the rubber height h.

Please comply with general technical instructions. Subject to technical alterations and deviations resulting from the manufacturing process.

APPLICATIONS

- for extremely elastic bearing of heavy machines, e.g.
 - ship's engines
 - large stationary motors
 - lathes and milling machines
 - elevator motors
 - jolters and vibration machines
- for high loads
- for limited space
- for compressive stress
- for superimposed compressive/shearing stress
- for damping sound and vibration

VERSIONS

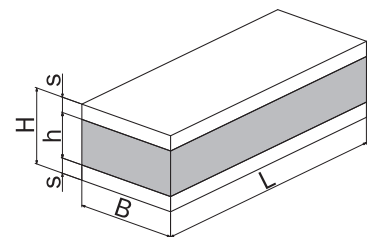

Type GMS-1

Screwable rubber-metal rail element

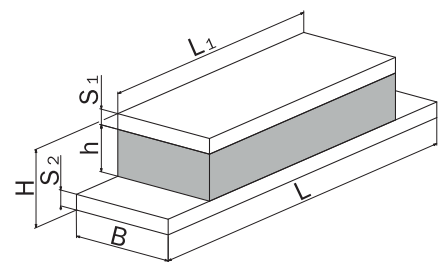

Type GMS-2

Screwable rubber-metal rail element - with protruding base rail at both ends

RUBBER-METAL ELEMENT TYPE GMF-1, GMF-2

MACHINE FEET WITH MALE OR FEMALE THREAD



STRUCTURE TYPE GMF-1, GMF-2 METAL PARTS / RUBBER ELEMENT

- **Type GMF-1** with female thread
- **Type GMF-2** with threaded bolt (male thread), adjustable in height for exact levelling
- Material: 1.0038 (S235JR) / 8.8
- Corrosion protection: oiled or electrogalvanized
- Conical rubber element with vulcanized metal casing (bell-shape)
- Nut (female thread) or threaded bolt (male thread) attached to the metal casing

Rubber grade	NBR
Rubber hardness	hard - 70 Shore A medium - 60 Shore A soft - 45 Shore A
Possible uses	Water, gas, fuel oil, mineral oil

DIMENSIONS / STRESS TYPE GMF-1

Form	Ø D	A	K	Ø L	H	G	Rubber hardness Shore A	Vertical Spring excursion max. mm	stress Load F_{tol}^* N	Artikel-Nr.	Pck. qty.
A	57.0	128	110	9.0	30	M 10	70	5	4400	51891400	8
A	57.0	128	110	9.0	30	M 10	60	5	3100	51891500	8
A	57.0	128	110	9.0	30	M 10	45	5	2200	51891600	8
A	88.5	170	140	13.0	39	M 12	70	5	7100	51890500	8
A	88.5	170	140	13.0	39	M 12	60	5	4600	51890800	8
A	88.5	170	140	13.0	39	M 12	45	5	2500	51891100	8
B	110.0	168	132	12.5	52	M 16	70	5	16000	51890600	4
B	110.0	168	132	12.5	52	M 16	60	5	11000	51890900	4
B	110.0	168	132	12.5	52	M 16	45	5	7000	51891200	4
B	125.0	184	150	13.0	63	M 20	70	4	24000	51890700	4
B	125.0	184	150	13.0	63	M 20	60	5	21000	51891000	4
B	125.0	184	150	13.0	63	M 20	45	5	12500	51891300	4

DIMENSIONS / STRESS TYPE GMF-2

Form	A	K	Ø L	R	S	F	Rubber hardness Shore A	Vertical Spring excursion max. mm	stress Load F_{tol}^* N	Artikel-Nr.	Pck. qty.
A	170	140	13.0	106	65	M 16 x 1.5	60	5	7500	51892400	8
A	170	140	13.0	106	65	M 16 x 1.5	45	5	4500	51892700	8
B	168	132	12.5	135	80	M 20 x 2.0	70	5	17500	51892100	4
B	168	132	12.5	135	80	M 20 x 2.0	60	5	12000	51892500	4
B	168	132	12.5	135	80	M 20 x 2.0	45	5	7000	51892800	4

* F_{tol} is the **tolerable static permanent load**: a dynamic alternating load can be superimposed. The stated tolerable loads are only approximate indications for the static load. Delivery only possible in the stated packaging quantities (far-right column).

NOTE

Please comply with general technical instructions. Subject to technical alterations and deviations resulting from the manufacturing process.

APPLICATIONS

- universal element for elastic bearing of machines of all kinds
- ideal for preventing horizontal movement of machine tools
- good, soft vertical elasticity with great horizontal stiffness
- for compressive stress
- for damping sound and vibration

VERSIONS

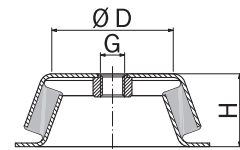

Type GMF-1 With female thread

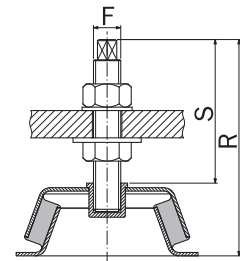

Type GMF-2 With male thread

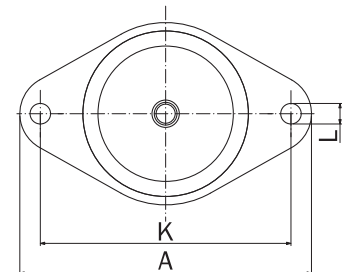

Form A

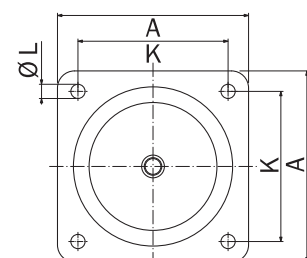

Form B

RUBBER-METAL ELEMENT TYPE GML-R

BEARING ELEMENT WITH THROUGH HOLE AND CENTERING COLLAR

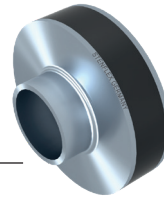

STRUCTURE TYPE GML-R METAL PARTS / RUBBER ELEMENT

- Bearing element with through hole for fastening with through bolts
- Material: 1.0038 (S235JR)
- Corrosion protection: oiled or electrogalvanized
- Cylindrical rubber element with metal plates vulcanized onto both sides

Rubber grade	NBR
Rubber hardness	hard – 70 Shore A medium – 60 Shore A soft – 45 Shore A
Possible uses	Water, gas, fuel oil, mineral oil

DIMENSIONS / STRESS

Ø D	Ø A	Ø B	Ø C	E	F	s	Rubber hardness Shore A	Compression stress Spring rate c_z N/mm	Load F_{tol}^* N	Art. No.	Pck. qty.
36	6.2	10	15	10	6.0	1.0	70	2000	2600	51895500	50
36	6.2	10	15	10	6.0	1.0	60	1350	1600	51895900	50
36	6.2	10	15	10	6.0	1.0	45	800	950	51896300	50
36	8.5	12	18	10	4.0	1.0	70	1550	1900	51895600	50
36	8.5	12	18	10	4.0	1.0	60	1000	1200	51896000	50
36	8.5	12	18	10	4.0	1.0	45	620	700	51896400	50
36	16.6	17	20	8	3.0	1.0	70	1900	1800	51874000	50
36	16.6	17	20	8	3.0	1.0	60	1250	1100	51874100	50
36	16.6	17	20	8	3.0	1.0	45	770	650	51874200	50
50	16.5	20	23	13	9.5	1.5	70	2200	3700	51895700	50
50	16.5	20	23	13	9.5	1.5	60	1500	2300	51896100	50
60	20.5	24	27	13	10.5	1.5	70	3000	6100	51895800	25
60	20.5	24	27	13	10.5	1.5	60	2000	3800	51896200	25
60	20.5	24	27	13	10.5	1.5	45	1050	2200	51896600	25

* F_{tol} is the **tolerable static permanent load**: a dynamic alternating load can be superimposed. The stated tolerable loads are only approximate indications for the static load. Delivery only possible in the stated packaging quantities (far-right column).

NOTE

Please comply with general technical instructions. Subject to technical alterations and deviations resulting from the manufacturing process.

APPLICATIONS

- highly versatile in e.g.
 - mechanical engineering
 - electrical industry
- for elastic bearing
- for compressive stress
- for shearing stress
- for superimposed compressive/shearing stress
- also for tensile stress (for pre-tensioned arrangement in pairs)
- for damping sound and vibration

VERSIONS

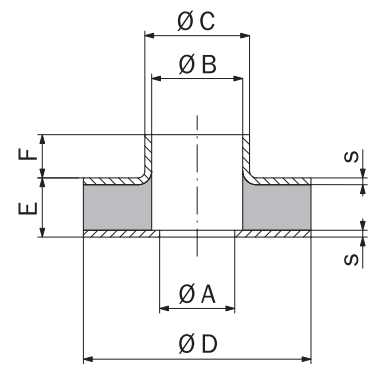

Type GML-R

With bore hole for through bolts

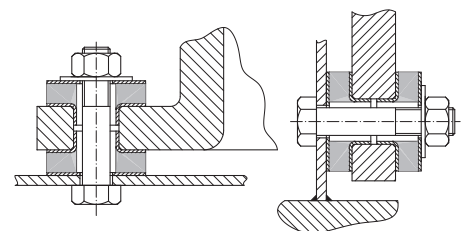

Arranged in pairs to interrupt structure-borne vibration

RUBBER-METAL ELEMENT TYPE GML-U

BEARING ELEMENT WITH MALE THREAD



STRUCTURE TYPE GML-U METAL PARTS / RUBBER ELEMENT

- Bearing element with U-profiles and attached threaded bolts (male thread)
- Material: 1.0038 (S235JR) / 8.8
- Corrosion protection: oiled or electrogalvanized
- Highly-elastic hollow rubber profile with vulcanized metal U-profiles

Rubber grade	NBR
Rubber hardness	hard - 70 Shore A medium - 60 Shore A soft - 45 Shore A
Possible uses	Water, gas, fuel oil, mineral oil

DIMENSIONS / STRESS

A	B	H	g	l	Rubber hardness Shore A	Vertical stress		Art. No.	Pck. qty.
						Spring excursion max. mm	Load F_{tol}^* N		
52	35	36	M 8	21	70	6	1600	51894500	12
52	35	36	M 8	21	60	6	1200	51894700	12
52	35	36	M 8	21	45	6	800	51894900	12
54	50	40	M 10	26	70	6	900	51894600	8
54	50	40	M 10	26	60	6	600	51894800	8
54	50	40	M 10	26	45	6	350	51895000	8

* F_{tol} impact or exciter forces must remain small. Tolerable static load values should only be exceeded to a minimum extent.
Delivery only possible in the stated packaging quantities (far-right column).

NOTE

Stress only possible in the direction of the threaded bolts' axis, i.e. shearing stress on the rubber element.

Please comply with general technical instructions. Subject to technical alterations and deviations resulting from the manufacturing process.

APPLICATIONS

- for elastic bearing of sensitive measuring instruments
- for shock-reducing bearing of apparatus and equipment
- for shearing stress
- for damping sound and vibration

VERSIONS

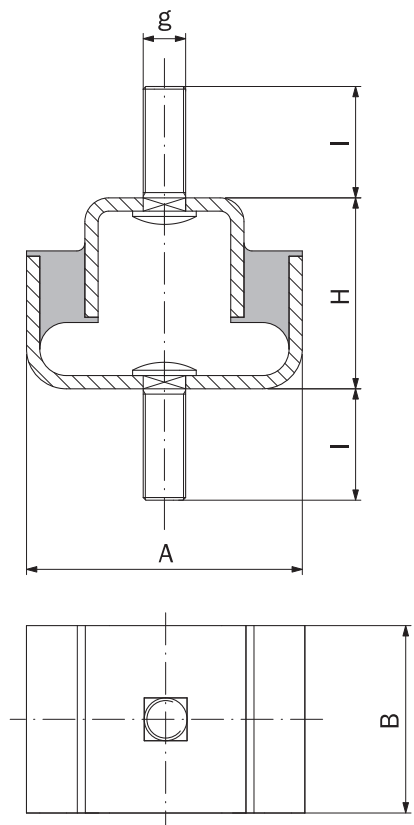

Type GML-U

Both sides with male thread

RUBBER-METAL ELEMENT TYPE GML-V, GML-W

BEARING ELEMENT WITH V- OR W-SHAPED RUBBER PROFILE



STRUCTURE TYPE GML-V, GML-W METAL PARTS / RUBBER ELEMENT

- Bearing element with metal rails and V- or W-shaped rubber profiles
- Through holes for fastening with through bolts
- Material: 1.0038 (S235JR) / 8.8
- Corrosion protection: oiled or electrogalvanized
- Highly-elastic hollow rubber profile with metal rails vulcanized onto both sides

Rubber grade	NBR
Rubber hardness	hard – 70 Shore A medium – 60 Shore A soft – 45 Shore A
Possible uses	Water, gas, fuel oil, mineral oil

DIMENSIONS / STRESS TYPE GML-V

B	H	S	L	L ₁	d	Rubber hardness Shore A	Vertical stress		Art. No.	Pck. qty.
							Spring excursion max. mm	Load F _{tol} * N		
25	30	2.5	68	36	6.5	70	3.5	300000	51895300	20
25	30	2.5	68	36	6.5	60	3.5	200000	51895200	20
25	30	2.5	68	36	6.5	45	3.5	100000	51895100	20

DIMENSIONS / STRESS TYPE GML-W

B	H	S	L	L ₁	d	d ₁	Rubber hardness Shore A	Vertical stress		Art. No.	Pck. qty.
								Spring excursion max. mm	Load F _{tol} * N		
25	30	2.5	135	72	6.5	8.5	70	3.5	600000	00002665	12
25	30	2.5	135	72	6.5	8.5	60	3.5	400000	00002572	12
25	30	2.5	135	72	6.5	8.5	45	3.5	200000	00002666	12

* F_{tol} is the **tolerable static permanent load**: a dynamic alternating load can be superimposed. The stated tolerable loads are only approximate indications for the static load. Delivery only possible in the stated packaging quantities (far-right column).

NOTE

Please comply with general technical instructions. Subject to technical alterations and deviations resulting from the manufacturing process.

APPLICATIONS

- highly versatile in use
- for elastic bearing of sensitive instruments
- special protection against shaking
- for compression stress
- for shearing stress
- for damping sound and vibration

VERSIONS

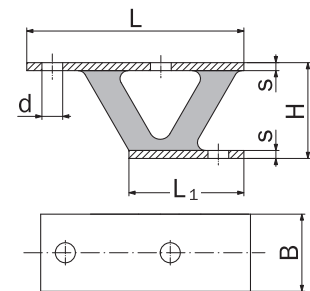

Type GML-V

Short version with V-shaped rubber profile

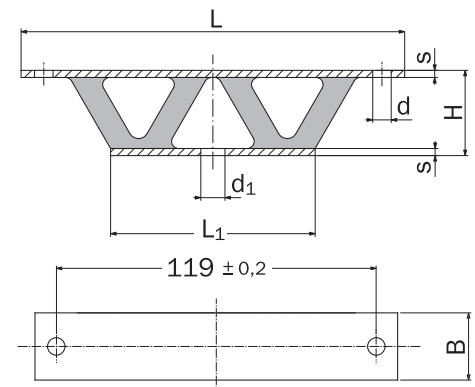

Type GML-W

Long version with W-shaped rubber profile

TECHNICAL ANNEX PROGRAMME OVERVIEW

WHETHER YOU ARE LOOKING FOR FLANGE CONNECTION DIMENSIONS, MATERIAL COMPARISONS, INFORMATION ON THE LAYOUT OF FIXED POINTS FOR PIPELINES OR CONVERSION TABLES – **ALL THE TECHNICAL DATA YOU NEED** AS WELL AS HELPFUL INFORMATION REGARDING FLEXIBLE PIPE CONNECTIONS.

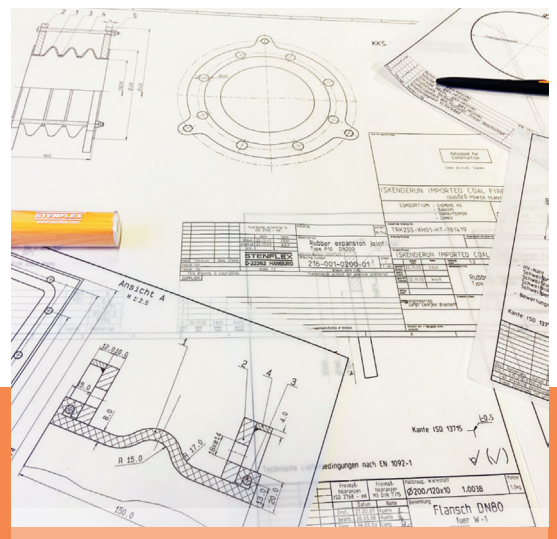

QUALITY.

TECHNICAL ANNEX

MOVEMENT AND FORCE AT EXPANSION JOINTS

MOVEMENT

Before opting for an expansion joint type, it is important to decide on how a change in length of a pipe system is to be compensated.

The choice of the expansion joint type depends essentially on the securing expansion, on the routing of the piping system and on the space available.

Pipe expansion can be absorbed by shift and deflection of a certain type of expansion joint.

When choosing an expansion joint the following types of movement must be considered:

- axial movement
- lateral movement
- angular movement

RUBBER EXPANSION JOINTS

If both axial and lateral (superimposed) movement are simultaneously introduced into a rubber expansion joint, its maximum extension in the axial direction and its ability to absorb the highest rated movement are reduced (see diagram 1).

The interrelation of superimposed angular and axial movement is shown in diagram 2.

STEEL EXPANSION JOINTS

If axial and lateral movement are simultaneously introduced into a steel expansion joint (superimposed movement), the lateral share is converted by an equation into an equivalent axial path and must not exceed 100 % when added. Please contact our Technical Consultation Service.

RUBBER EXPANSION JOINTS: INFLUENCE OF TEMPERATURE ON THE PERMISSIBLE INNER PRESSURE

The maximum permissible operating pressure of rubber expansion joints stated in the data sheets refers to a temperature of 20 °C. The pressure must be reduced with rising temperature as the strength of bellows materials decreases with rising temperature (see table).

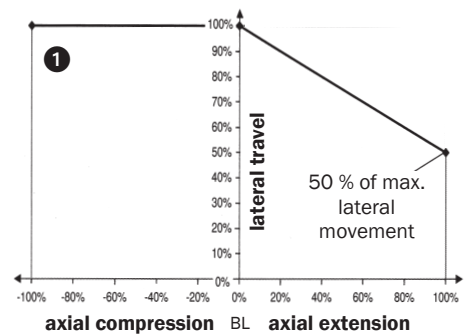

Restriction of the lateral movement with simultaneous axial movement (universal expansion joints)

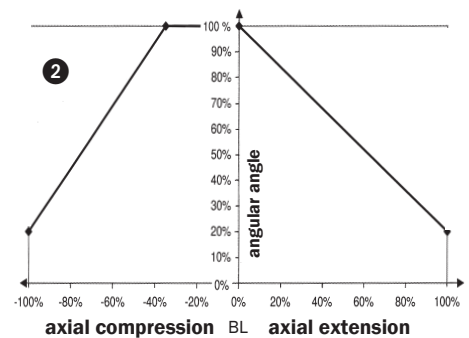

Restriction of the angular deflection with simultaneous axial movement (universal expansion joints)

MAX. PERMISSIBLE OPERATING PRESSURE (BAR)

Temperature °C	Type series									
	A. AG. B. R bar	AS. RS bar	AR bar	GR-SAE bar	E. G bar		C bar			W bar
20	16	16	25	16	10	16	4	10	16	2.5
30	16	16	25	16	10	16	4	10	16	2.5
40	16	16	25	16	10	16	4	10	16	2.5
50	16	16	25	16	10	16	4	10	16	2.5
60	16	16	25	16	10	16	4	10	16	2.5
70	14	15	22	15	9	14	3.5	9	14	2
80	11	14	20	14	7	11	2.8	7	11	1.7
90	6	12	16	12	4	6	1.5	4	6	1
100	6*	10	11	10	4*	6*	1.5*	4*	6*	1*
110		6	6	6						
120		6*	6*	6*						
130		6*	6*	6*						

*for brief periods (max. 100 hours)

FORCE OF AXIAL EXPANSION JOINTS

Axiale compression force F_D referred to structural length (reaction force)

Axial compression force is the longitudinal force resulting from internal pressure.

F_D = axial compression force (N)
 A = effective bellows cross sectional area (cm²) (see data sheet tables)
 p = internal pressure (bar)

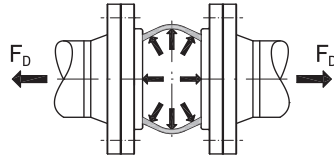

$$F_D = A \cdot p \cdot 10$$

Axial bellows moving force F_{ax}

The axial bellows moving force is the force required for the axial movement of the bellows.

It results from the stiffness of the bellows together with the movement.

c_{ax} = axial bellows moving rate (N/mm)

Δ_{ax} = axial travel (mm)
 + = sign for compression
 - = sign for extension

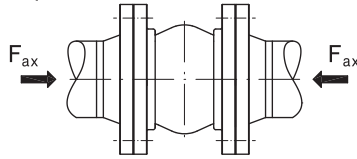

$$F_{ax} = c_{ax} \cdot \Delta_{ax}$$

Axial bellows total force F_{axB}

Addition of axial compression force and axial bellows moving force

F_{axB} = total axial force of the bellows (N)
 + = compression force on pipe
 - = tensile force on pipe

$$F_{axB} = F_D + F_{ax}$$

FORCE OF LATERAL EXPANSION JOINTS

Lateral bellows moving force F_{latB}

The lateral bellows moving force is the force required for the lateral movement of the bellows. It results from the stiffness of the bellows together with the movement.

F_{latB} = lateral bellows moving force (N)
 c_{lat} = lateral bellows spring rate (N/mm)
 Δ_{lat} = lateral travel (mm)

$$F_{latB} = c_{lat} \cdot \Delta_{lat}$$

Total lateral moving force F_{lat}

STENFLEX® lateral expansion joints are equipped with tie rod restraints. The tie rods absorb axial compression force described for axial expansion joints.

But this compression force generates friction force at the tie rod hinges which must be overcome with the lateral movement.

The moving force of lateral expansion joints is calculated as follows:

F_{lat} = total lateral moving force (N)
 F_{fric} = friction force from tie rod hinges (N)

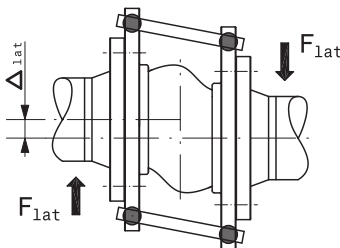

$$F_{lat} = F_{latB} + F_{fric}$$

The moving force, introduced into the lateral expansion joints, is not as high as in unrestrained axial or universal expansion joints, but is still transferred to the pipe and needs to be accounted for when rating the fixed points.

MOMENT OF ANGULAR EXPANSION JOINTS

Angular bellows moving moment M_{angB}

The angular bellows moving moment is the period required for the angular movement of the bellows. It results from the stiffness of the bellows together with the angular movement.

$$M_{angB} = c_{ang} \cdot \Delta_{ang}$$

M_{angB} = angular bellows moving moment (Nm)

c_{ang} = angular bellows moving rate (Nm/degrees)

Δ_{ang} = angular moving angle (degrees)

Total angular moving moment M_{ang}

STENFLEX® angular expansion joints are equipped with angular hinges. The hinge restraints absorb axial compression force described for axial expansion joints. But this compression force generates friction force at the angular hinges which must be overcome with the angular movement.

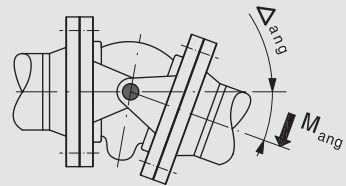

$$M_{ang} = M_{angB} + M_{fric}$$

The moving moment of restrained angular expansion joints is calculated as follows:

M_{ang} = total angular moving moment (Nm)

M_{fric} = friction moment in the hinges (Nm)

Effective bellows cross sectional areas, moving rates and friction force or moments are specific to the type or manufacture, and depend on operating conditions. Please inquire for further details.

ATTENTION!

Lateral expansion joints with tie rod restraints are not designed for axial adjusting movements. However, if axial adjusting movements are initiated, the tie rod restraints cannot compensate the compressive force and will be transferred to the fixed points of the piping instead.

TECHNICAL ANNEX

PIPE FIXED POINTS FOR EXPANSION JOINTS AND PIPE CONNECTORS

As a flexible pipe element, an expansion joint or pipe connector separates the rigid system and destabilizes the pipe if there are no fixed points. Positive internal pressure induces force into the pipe. Direction and degree of the force depend on the nominal diameter, pipe internal pressure, movement being absorbed and the pipe routing. A lack of fixed points (see fig. 1) will cause the pipe to shift. The flexible element would be stretched to its load limits and, eventually this would cause the elastic connection to break.

When rating fixed points, the following force must be taken into account:

- F_D = axial compression force (from positive inner pressure in the pipe)
- F_{axB} = total axial force of the expansion joint
- F_{lat} = total lateral moving force of the expansion joint
- M_{ang} = total angular moving moment of the expansion joint
- F_{fricFL} = friction force at the guide bearings
- F_{cent} = centrifugal force from pipe diversions (at high flow speeds)

In addition to the fixed points (see fig. 3), functionally safe operation of expansion joints and pipe connections also requires flawless pipe routing.

Guide bearings (see fig. 2) prevent the pipe from buckling.

We differentiate between the following fixed points and guides:

- HFP = main fixed point
- ZFP = intermediate fixed point
- KFP = knee fixed point
- FL = guide bearing (plain bearing)

Pipes with unrestrained expansion joints or pipe connectors must be equipped with robust fixed points and guides. The main fixed points must absorb F_{axB} and F_{fricFL} force.

Special care must be given to correct rating and design of the fixed points. They must be robust enough to withstand negative effect on supports (e.g., on building wall, ceiling or steel structure), when pipe force is introduced.

Fixed points are also necessary for unpressurized operation where vibration must be compensated to relieve the pipe, or if several expansion joints or pipe connectors are fitted in a pipeline system.

In an unstable pipe system (see fig. 4), an expansion joint or pipe connector cannot perform its function; pipe force cannot be absorbed.

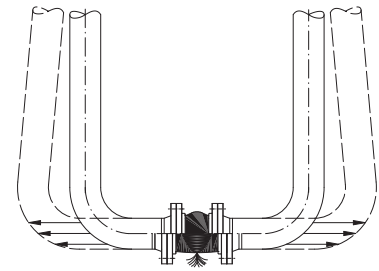

Fig. 1: Lack of fixed points

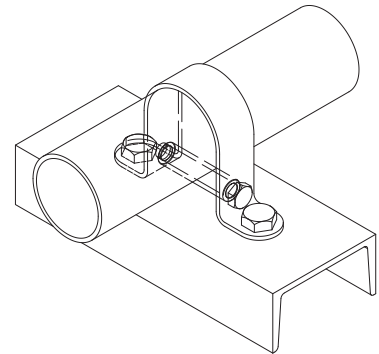

Fig. 2: Pipe guide bearing with rollers

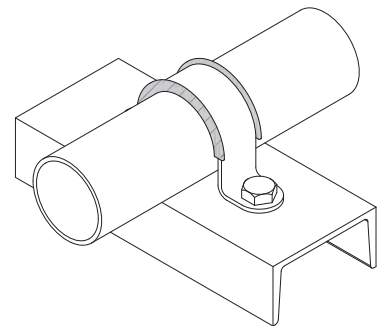

Fig. 3: Fixed point design

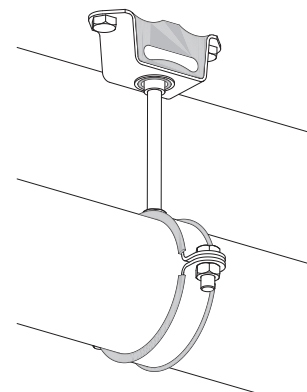
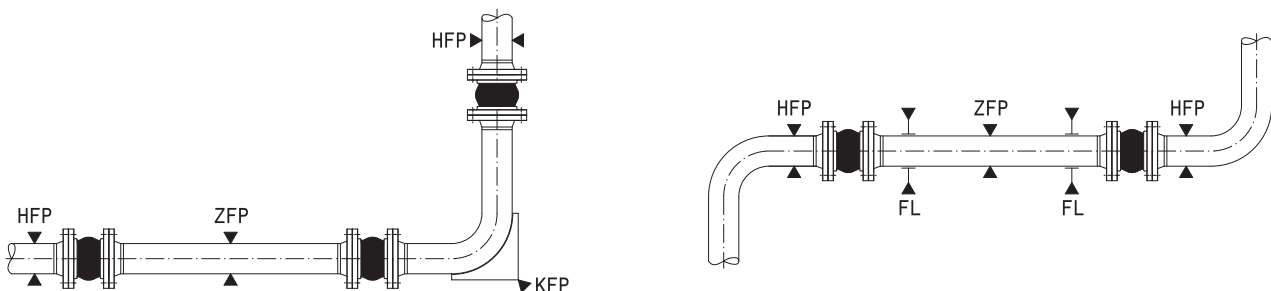

Fig. 4: Pendulum-type pipe suspensions are not fixed points



At pipe deflection points the main fixed points (HFP) and knee fixed points (KFP) absorb the full reaction force. The intermediate fixed points (ZFP) are practically relieved of pressure.

ARRANGEMENT OF FIXED POINTS AND GUIDE BEARINGS FOR AXIAL EXPANSION JOINTS AND PIPE CONNECTORS

L1 L1 L2 L3 L3

HFP FL FL FL ZFP

Arrangement of an expansion joint beside a main fixed point

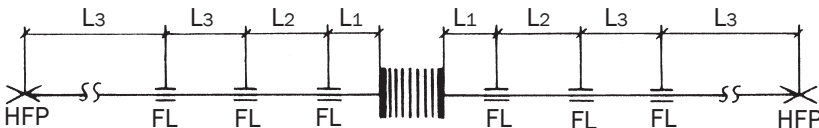

Arrangement of an expansion joint between two guide bearings

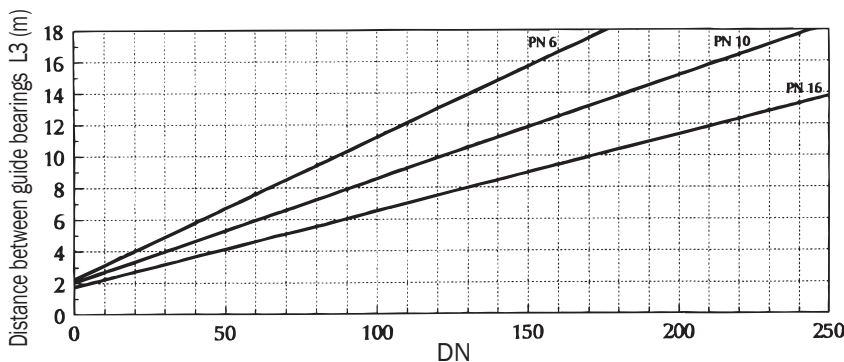

Distance between guide bearings

L_1 = distance between expansion joint/ pipe connector and fixed point or distance between expansion joint/ pipe connector and 1st guide bearing ($L_1 \leq 3 \times DN$)

L_2 = distance between 1st guide bearing and 2nd guide bearing ($L_2 = 0,5 \times L_3$)

L_3 = normal distance between 2 guide bearings

L_3 must be seen in the context of the weight and nominal diameter of the pipe together with the positive inner pressure (for indicative values see diagram).

The pipe must be guided exactly through the bearing. Guide bearings must be placed on both sides of the expansion joint. A fixed point replaces a guide bearing. Internal guide sleeves are unsuitable as pipe guides.

ARRANGEMENT OF FIXED POINTS FOR LATERAL AND ANGULAR EXPANSION JOINTS

Pipes with lateral and angular expansion joints must also be equipped with fixed points, even though axial compression force F_D is absorbed by the restraint. Here only lateral moving force F_{lat} resp. angular moving moment M_{ang} needs to be absorbed.

As a rule only one compensation system may be placed between two fixed points. When several compensation systems are fitted into the pipe system, fixed points must be provided between them.

Hinged expansion joints have a given rotation axis around which they can revolve.

When arranging a expansion joint system, the correct position of the rotation axes must be considered.

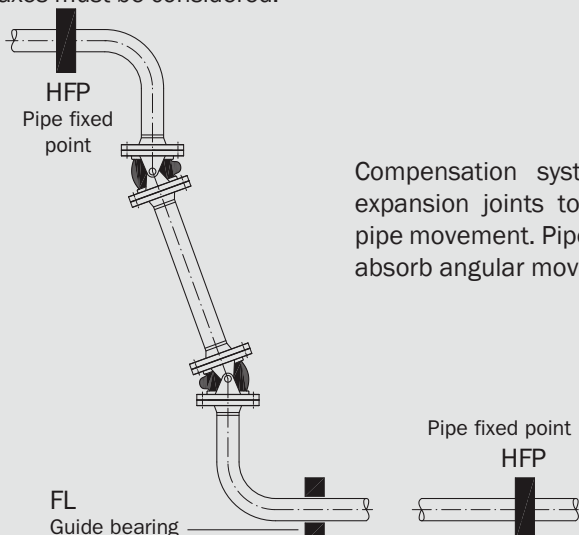

Compensation system with two angular expansion joints to compensate for large pipe movement. Pipeline with fixed points to absorb angular moving moment.

ARRANGEMENT OF FIXED POINTS AT PUMPS

Appliances such as pumps are de-coupled from the pipe system by expansion joints or pipe connectors. The pump housing is relieved of pressure and tension. The force is absorbed by correctly positioned pipe fixed points.

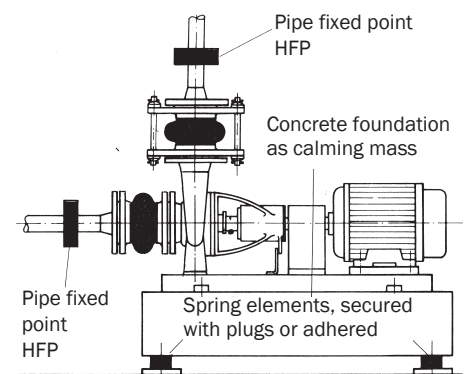

Pump appliance in elastic mount, silenced pipe connection with rubber expansion joints.

TECHNICAL ANNEX

REDUCING THE SOUND LEVEL BY RUBBER EXPANSION JOINTS

REDUCING THE SOUND LEVEL, EXAMPLE EXPANSION JOINT TYPE AS

Diagram 1

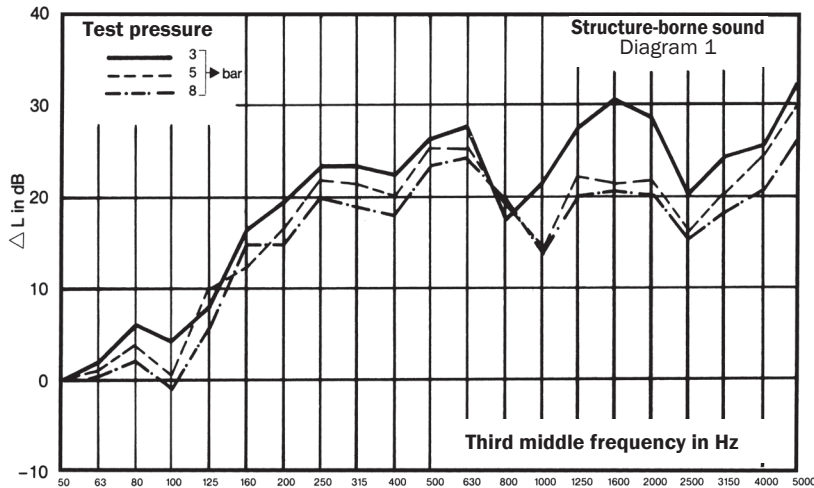

Diagram 2

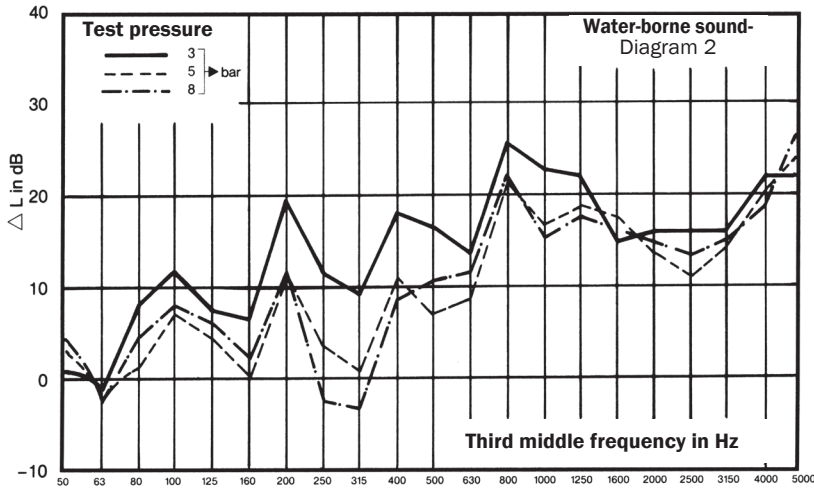

Diagram 3

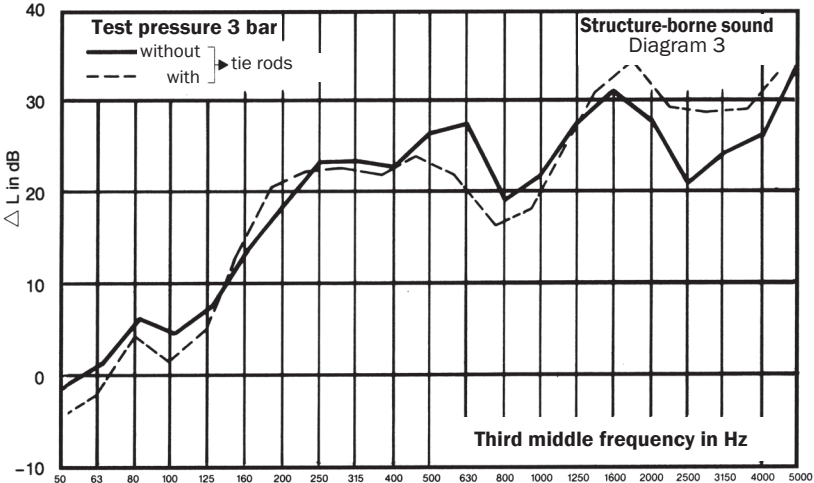

Diagram 1 and 2

Both diagrams show the degree of structure-borne and water-borne sound absorption, depending on operating pressure when using rubber expansion joints type AS.

The insulation values of this expansion joint differ scarcely from those with synthetic fibre reinforcement (e.g., type A). Please note: The attained value 20 dBA corresponds to a damping efficiency of approx. 90 %.

Diagram 3

Thanks to the special structure of the tie rod restraint (types AS-2, and AS-4), the sound absorption is almost the same as in unrestrained expansion joints.

Tie rod restraints are carried in rubber sockets for sound absorption up to DN 150 as a standard feature

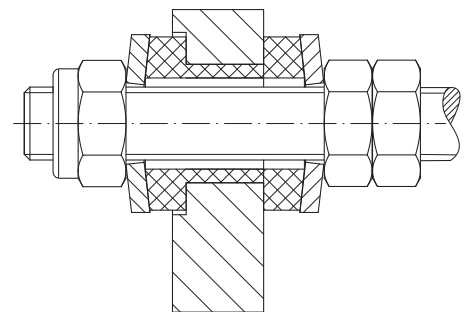

- outside in type AS-2
- outside and inside in type AS-4.

The structure-borne sound which is carried through the tie rods is ideally interrupted by the rubber sockets.

Our studies are based on sound absorption requirements in accordance with DIN 4109.

TECHNICAL ANNEX

ABSORBING EXPANSION BY STEEL EXPANSION JOINTS

THERMAL EXPANSION OF PIPES

Pipe movement to be absorbed is calculated primarily from the thermal expansion caused by changes in temperature, with the change in length of the pipe being the dominant factor.

The change in length, calculated this way, can be compensated for by axial, lateral and also angular means. The suitable expansion joint is selected from the data sheets on the basis of the calculated change in length.

Movement is calculated according to the following equation:

$$\Delta L = L \cdot \alpha \cdot \Delta T$$

ΔL = change in length of the pipe (mm)

L = length of the pipe (mm)

α = length expansion coefficient

$$\left(\frac{1}{K} \right)$$

ΔT = change in temperature (K)

Pipe material	Length expansion coefficient α at +20 °C (K)
1.0038 (S235JR)	$11,1 \cdot 10^{-6}$
1.0345 (P235GH)	$11,9 \cdot 10^{-6}$
1.4541	$16,0 \cdot 10^{-6}$
1.4404	$16,5 \cdot 10^{-6}$
Copper	$16,8 \cdot 10^{-6}$
Aluminium	$23,8 \cdot 10^{-6}$
Polypropylene	$110,0 \cdot 10^{-6}$

ABSORPTION OF EXPANSION BY NOT PRE-TENSIONED EXPANSION JOINTS

Standard STENFLEX® expansion joints are supplied in a neutral setting, i.e. the expansion joints can be moved in all directions (\pm axial, lateral and angular). The tolerable movement is stated in the corresponding data sheets for each nominal diameter. When using angular expansion joints, in double or triple joint systems, the overall system movement depends not only on the angular movement values of the expansion joint but also on the length of pipe section between the expansion joints.

ABSORPTION OF EXPANSION BY PRE-TENSIONED EXPANSION JOINTS

A expansion joint can be pre-tensioned for change in length of the pipe in just one direction. This achieves effective utilisation of the total movement as stated in the data sheets.

The installation length of a pre-tensioned steel expansion joint is calculated according to equation:

$$EBL_t = BL + \frac{\Delta L}{2} - \Delta L \cdot \frac{t_e - t_{min}}{t_{max} - t_{min}}$$

The expansion joints should, where possible, be mounted in a neutral setting and then pre-tensioned by moving the pipe section or by removing the length needed to install the expansion joint.

The absorption of expansion (Δ) of two-joint systems depends on the center distance (L) of the expansion joints and the maximum tolerable angle of deflection (α). It is calculated according to equation:

$$L = \frac{\Delta/2}{\sin \alpha}$$

$$\Delta/2 = L \cdot \sin \alpha$$

The expanding pipe must have play corresponding to the radian measure in the guide bearing. This measure is calculated as follows:

$$h = L (1 - \cos \alpha)$$

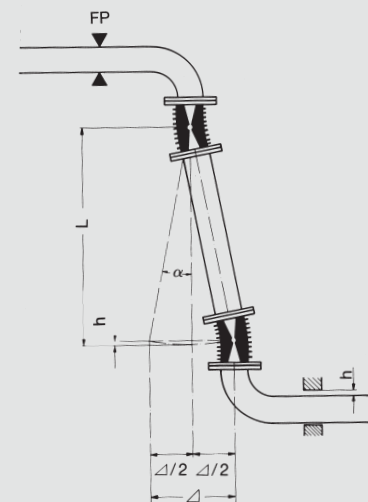

Installation at 50 % pre-tension

EBL_t = temperature depending on installation length of the pre-tensioned expansion joint (mm)

BL = installation length of the steel expansion joint (mm)

ΔL = change in length of the pipe (mm)

t_e = temperature during installation (°C)

t_{min} = minimum temperature occurring in the pipe (°C)

t_{max} = maximum temperature occurring in the pipe (°C)

TECHNICAL ANNEX

ABSORBING EXPANSION BY STEEL EXPANSION JOINTS

ABSORBING EXPANSION

Operation conditioned diminution factors for steel expansion joints

The table values stated in the data sheets refer to 1.4541 as bellows material at a temperature of +20 °C and 1000 load cycles.

Temperature, inner pressure, movement and load cycle of an expansion joint are all directly related. If operating conditions deviate from the above stated values, the diminution coefficients stated in the following diagrams can be used as indicative values.

The strength of the bellows materials decreases with increasing temperature, so that pressure and tolerable movement as stated in the data sheets must be reduced as temperature increases.

Exact rating is only possible with corresponding calculating programs.

Diagram 1 - Decrease in pressure from the influence of temperature

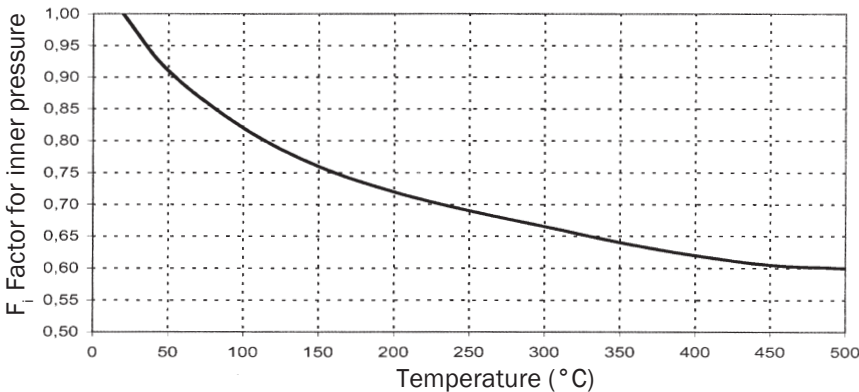

Diagram 2 - Reduction in movement from the influence of temperature

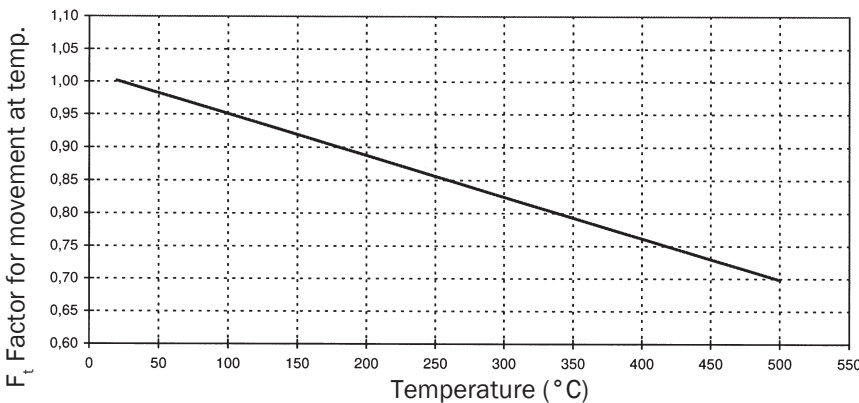
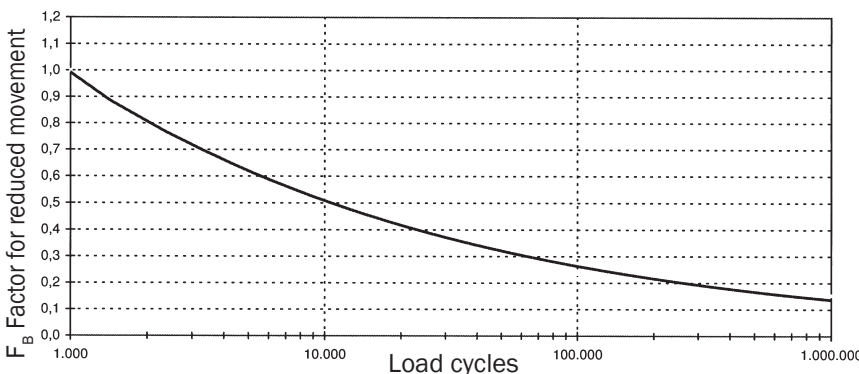

Diagram 3 - Influence of movement on the number of load cycles



INFLUENCE OF TEMPERATURE ON TOLERABLE INNER PRESSURE

$$P_{tol} = PN \cdot F_i$$

P_{tol} = max. tolerable pressure at stated temperature

PN = nominal pressure

F_i = factor for inner pressure (from diagram 1)

INFLUENCE OF TEMPERATURE ON TOLERABLE MOVEMENT

$$\Delta B_{tol} = \Delta B_{tab} \cdot F_t$$

ΔB_{tol} = max. tolerable movement of the expansion joint

ΔB_{tab} = movement absorption according to data sheets

F_t = factor for movement at stated temperature (diagram 2)

INFLUENCE OF MOVEMENT ON TOLERABLE NUMBER OF LOAD CYCLES

$$F_B = \frac{\Delta B_{act}}{\Delta B_{tab}}$$

F_B = factor for reduced movement

ΔB_{act} = actual movement

ΔB_{tab} = tolerable movement from data sheets (see Diagram 3)

F_B can be used to calculate the tolerable number of load cycles. If the actual movement of the expansion joint is smaller than the tolerable movement, then the number of load cycles of the expansion joint increases.

TECHNICAL ANNEX

INSTALLATION AND OPERATING INSTRUCTIONS FOR RUBBER EXPANSION JOINTS AND PIPE CONNECTORS

STENFLEX® expansion joints and pipe connectors can only fulfil their function when installed and fitted correctly. The service life is affected not only by the operating conditions but above all by correct installation. Expansion joints and pipe connectors are not simple pipe elements but moving parts which require regular inspection.

Expansion joints and pipe connectors are individual components of a pipeline system manufactured by STENFLEX®. STENFLEX® assumes no guarantee for imitation products or modifications to original products.

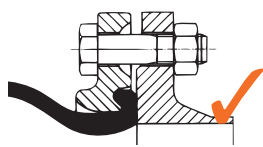

The sealing faces of the counter flange must be smooth and clean.

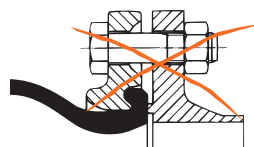

Flanges with groove and tongue are not allowed.

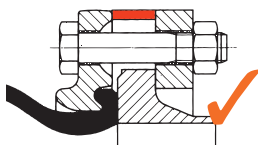

Spacer pieces or rotating flanges with welding stub must be used to level gaps.

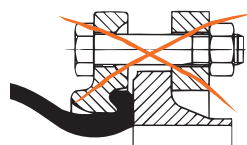

Rotable flanges with short stub end are unsuitable: no uniform full-circumference surface pressure.

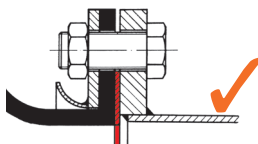

Additional flat seals (65+5 Shore A) protect the rubber sealing face from sharp-edged pipe ends.

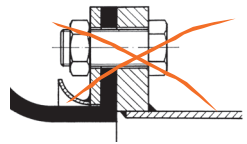

Sharp-edged pipe ends cut into the rubber sealing face.

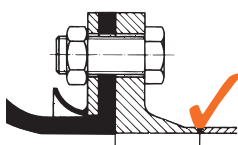

For full-faced rubber flanges, uniform full-circumference surface pressure is only possible with smooth mating flanges.

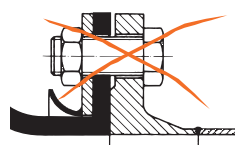

Mating flanges with raised shoulder will squash the rubber flange, the press-on retaining flange warps – insufficient surface pressure.

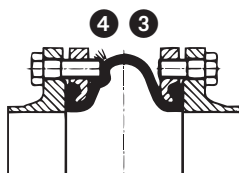
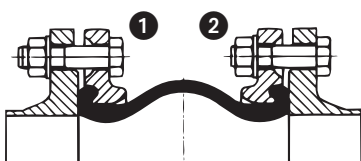

- Expansion joints are to be mounted according to ① i.e. the screw head always shall be positioned on the bellows' and the screw nut on the piping side. If this is not possible the screw length for ② must be selected so as not to damage the bellows. In the case of flanges with threaded holes, make sure that the screw length is flush with the flange as far as possible ③. The risk of damage from screws that are too long increases when the rubber bellows expands when operating under pressure ④.
- The inside of the pipeline as well as the flange sealing areas must be coated with an effective corrosion protection for aggressive media (e.g. sea water, acids, lyes etc.)
- During installation ensure that the bores in the pipe flanges are aligned. If necessary, adjust rotatable flanges at the expansion joint or pipe connector.

INSTALLATION

- The expansion joint or pipe connector must be kept clean and dry. When stored out in the open, it must be protected from intense sunshine and weather.
- Prior to installation, check the packaging and expansion joint or pipe connector for signs of damage. If any sign of damage whatsoever is detected the product must not be installed.
- Keep the expansion joint or pipe connector clear of any foreign matter e.g., dirt, insulation etc. on the inside and outside, and check again accordingly before and after installation.
- Do not remove transport safeguards and protective caps until immediately before installation.
- Expansion joints and pipe connectors must only be installed by authorized qualified personnel. Appropriate accident prevention regulations must be observed.
- Do not throw, or jolt, the expansion joint or pipe connector; protect from falling objects. Do not attach chains or cables directly to the bellows.
- Special seals are not required because the expansion joints and pipe connectors are self-sealing. The sealing faces of the flanges must be smooth and clean. Additional seals are not required; a seal only needs to be inserted when fitting internal guide sleeves.
- Insert rubber expansion joints with vacuum supporting rings for negative pressure operations.
- The length of the installation gap shall be equal to the installation length of the expansion joint.
- The expansion joint shall preferably be stressed by compression.

TECHNICAL ANNEX

INSTALLATION AND OPERATING INSTRUCTIONS FOR RUBBER EXPANSION JOINTS AND PIPE CONNECTORS

INSTALLATION

- Evenly tighten the flange screws crosswise. In order to avoid damages to the bellow caused by tools, keep the screw head with the key inside and turn the nuts outside. Retighten the screws after first commissioning.
- It is important to ensure that there is no torsion strain (twisting) on the expansion joint or pipe connector during assembly/dismantling and during operation. This applies in particular to types with threaded connection: hold these with a key at the hexagon.
- When electric welding is carried out on the pipe near the expansion joint or pipe connectors they must be bridged with earthing cables. Expansion joints and pipe connectors must always be protected from welding splashes and thermal load during welding work.
- Wherever possible install expansion joints or pipe connectors so that they can be visually checked at regular intervals for possible damage.
- Cover expansion joints or pipe connectors to prevent damage of any kind.
- The installation of a guide sleeve is required for flow with abrasive media and of high velocity as well as for possibly resulting reactions or turbulences by diverting the flow direction (e.g. behind pumps, valves, T-pieces, pipe bends). The flow direction needs to be observed for installation (arrow direction = flow direction).
- Do not paint the bellows, do not apply any insulation.
- Do not remove the pre-tensioning safeguards until after installation.
- The pipes must be equipped with adequately rated fixed points and pipe guides to absorb pipe force (see chapter: 'Movement, force, pipe fixed points.') The operator is responsible for correct rating.
- The fixed points of the pipe system must only be fastened after the expansion joint has been mounted (after flange screws have been tightened).
- In general the manufacturer does not conduct pressure tests according to Annex 1, section 3.2.2 of the pressure equipment directive PED 2014/68/EU. This is the responsibility of the operator after installation in the pipe system ($PT = 1.43 \times PS$).
- The operator must provide the necessary safety and monitoring devices for the pipe system (e.g., installation of temperature sensors, pressure reduction valves, measures to prevent pressure pulses and water hammers).

INITIAL COMMISSIONING

- Expansion joints and pipe connectors with restraints have been adjusted to the structural length (BL) in the factory. The tie rods must be connected to the flanges with a positive connection after installation.
- Only proceed with pressure and leak tests after the fixed points and guide bearings have been installed correctly. Otherwise the expansion joint will extend in length and become useless.
- During operation at high temperatures the operator must take safety precautions to prevent injury to persons inadvertently touching hot surfaces.

- To guarantee safe operation the expansion joints and pipe connectors must only be operated within the permitted ranges of pressure, temperature and movement.
- Consider table on page 198.
- The operator is responsible for precautions that will prevent incorrect use of expansion joints or pipe connectors by ensuring that the staff have been instructed accordingly and are supervised adequately, and by providing safety equipment and operating instructions.

USE

- Before using the expansion joints or pipe connectors check the media resistance (if in doubt, please inquire).
- Guide sleeves must be installed in the expansion joints for a flow containing aggressive media and in the event of high flow velocities or turbulent flows.
- To avoid fire damage, expansion joints and pipe connectors can be provided with additional flameproof covers.
- The operating data as stated in the data sheets, design drawings and on the nameplate are the application limits for use. STENFLEX[®] assumes no liability for damage caused by operation outside these limits. The operator is responsible for complying with these specifications (e.g. by using safety devices).

Detailed installation, and operating instructions which also stipulate screw torques are enclosed with every expansion joint and pipe connector.

INSPECTION AND MAINTENANCE

- The operator must ensure that the expansion joints and pipe connectors are freely accessible so that visual inspections can be carried out at regular intervals.
- Check the expansion joints and pipe connectors for flawless condition in accordance with valid standards. In the case of faults such as blistering, surface cracks or irregular deformation, please contact our Technical Consultation Service. Repairs are not permitted.
- The Shore hardness of the flexible rubber elements in expansion joints and pipe connectors must be checked at regular intervals. If the hardness exceeds 83 Shore A, the element must be replaced, for safety reasons.
- Avoid using chemically aggressive media to clean the pipe system. The media and the corrosion resistance are to be observed.
- The expansion joints and pipe connectors can be cleaned with soap and warm water. Never use sharp or pointed objects such as wire brushes or sandpaper.

INSTRUCTIONS FOR RUBBER EXPANSION JOINTS AT PUMPS

- Connect the expansion joints or pipe connectors as close to the pump flange as possible. (see Fig. M1). Exception: a spacer pipe should be used where abrasive media are concerned.
- When using centrifugal pumps to pump abrasive media, the expansion joints or pipe connectors must not be positioned directly on the pump fitting (suction/discharge side).
- Otherwise there is a risk that the expansion joints could be damaged by the high relative speeds caused by swirling and eddying at the pump connection.
- The spacing between the pump connection and the expansion joint or pipe connector must be 1 to $1.5 \times DN$ (see Fig. M2)
- In the case of negative pressure on the suction side, use a rubber expansion joint with vacuum supporting ring.
- Avoid operating pumps against completely or partially closed gate valves. Also avoid cavitation! This can destroy the expansion joint or pipe connector in a very short time.

Fig. M1

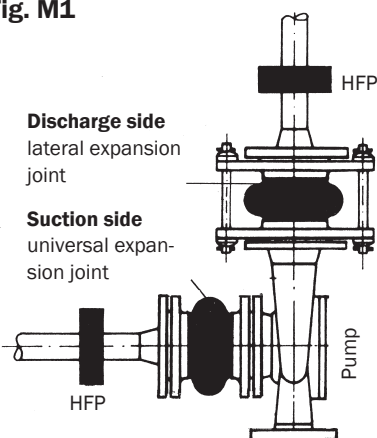

Recommendation for arranging expansion joints at pumps (normal case)

Fig. M2

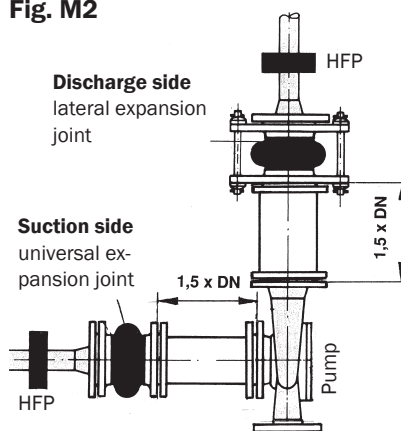

Pumping media with abrasive solid particles (special case)

SPECIAL INSTRUCTIONS FOR PIPE CONNECTORS

Rubber-metal pipe connectors are intended as decoupling elements to prevent sound transmission and to dampen vibration only. They are not to be used to absorb low frequency oscillation, expansion, tension or to compensate misalignment in the pipeline.

- During installation use only the screw lengths and washers as stated in the data sheets and attached installation instructions.
- The length of the gap in the pipe system must equal that of the pipe connector. No tensile force must be introduced into the rubber-metal pipe connector.
- Install the rubber-metal pipe connector free of tension, do not subject to tension, torsion or bending. Do not use as a expansion joint!

DECLARATION OF CONFORMITY

STENFLEX® rubber-type expansion joints of the series A, AR, AS, AG, B, C, E, G, GR-SAE, MS, R, RS and W have been subjected to the conformity assessment procedure and comply with the Pressure Equipment Directive 2014/68/EU.

Rubber expansion joints subject to the Pressure Equipment Directive are marked with the CE-sign and the tag-number of the designated location.

TECHNICAL ANNEX

INSTALLATION AND OPERATING INSTRUCTIONS FOR STEEL EXPANSION JOINTS

STENFLEX® steel expansion joints can only fulfil their proper function when installed and fitted correctly. The service life is affected not only by the operating conditions but above all by correct installation. Expansion joints are not simple pipe elements but moving parts which require regular inspection. STENFLEX® steel expansion joints are individual components of a pipe system.

STENFLEX® assumes no guarantee for imitation products or modifications to original products.

INSTALLATION

- The expansion joint must be kept clean and dry.
- Prior to installation, check the packaging and expansion joint for signs of damage. The expansion joint must not be installed if you detect any signs of damage to the steel bellows whatsoever.
- Keep the expansion joint clear of foreign matter such as dirt, insulation etc., on the inside and outside, and check again before and after installation.
- Do not remove transport safeguards and protective covers until immediately before installation.
- Expansion joints must only be fitted by authorized qualified staff. Appropriate accident prevention regulations must be observed.
- Do not throw, or jolt, the expansion joint; protect from falling objects. Do not fit chains, or cables, directly to the bellows.
- The sealing faces of the flanges must be smooth and clean.
- The length of the gap in the structure, should equal the structural length of the expansion joint.
- During installation ensure that the bores of the pipe flanges are aligned. If necessary, adjust rotatable flanges at the expansion joint.
- Screw heads should always be placed on the bellows side, nuts on the piping side
- Evenly tighten the flange screws crosswise. In order to avoid damages to the bellow caused by tools, keep the screw head with the key inside and turn the nuts outside. Retighten the screws after first commissioning.
- It is important to ensure that there is no torsion strain (twisting) on the expansion joint during assembly/dismantling and during operation. This applies in particular to types with threaded connection: hold these with a key at the hexagon.
- When electric welding is carried out on a segment of pipe near the expansion joint it must be bridged with earthing cables. Expansion joints must always be protected from welding splashes and thermal load during welding work.
- When welding steel expansion joints into the pipeline, only use certified materials and welding procedures.
- No welding is allowed on the bellows (this includes ignition points).
- The installation of a guide sleeve is required for flow with abrasive media and of high velocity as well as for possibly resulting reactions or turbulences by diverting the flow direction (e.g. behind pumps, valves, T-pieces, pipe bends). The flow direction needs to be observed for installation (arrow direction = flow direction).
- DVGW-tested expansion joints must only be installed with the enclosed DVGW-tested seals.

- As far as possible, install expansion joints so that they can be visually checked at regular intervals for possible damage.
- Do not apply paint or insulation to the bellows.
- Do not remove the pre-tension safeguards until installation has been completed.
- The pipes must be provided with adequately rated fixed points and pipe guides that absorb pipe force. The operator is responsible for correct rating.
- The fixed points of the pipe system must only be fastened after the expansion joint has been mounted (after flange screws have been tightened).
- The operator must provide the necessary safety and monitoring devices for the pipe system (e.g., temperature sensors, pressure control valves, measures to avoid pressure pulses and water hammers, etc.).

INITIAL COMMISSIONING

- Expansion joints with restraints (lateral and angular expansion joints) have been adjusted to the structural length (BL) at the factory. The tie rods must be connected to the flanges with a positive connection after installation.
- Only proceed with pressure and leak tests after the fixed points and guide bearings have been installed correctly. Otherwise the expansion joint will extend in length and become useless.
- Do not exceed the permitted test pressure.
- Do not exceed the allowable temperature $T_s \text{ max}$
- Do not fall below the allowable temperature $T_s \text{ min}$
- During operation at high temperatures the operator must take safety precautions to prevent injury to persons inadvertently touching hot surfaces.
- To guarantee safe operation the expansion joints must only be operated within the permitted pressure, temperature and movement limits.
- The operator is responsible for precautions that prevent incorrect use of expansion joints by ensuring that staff have been instructed accordingly and are supervised adequately, and by providing safety equipment and operating instructions.

USE

- Before using the expansion joints take note of their media resistance (If in doubt please inquire).
- The installation of a guide sleeve is required for flow with abrasive media and of high velocity as well as for possibly resulting turbulences.
- The operating data as stated in the data sheets or design drawings and on the name plate, are the limits of application for use. STENFLEX® assumes no liability for damage caused by operation outside these limits. The operator is responsible to comply with these specifications.
- The values given in the dimension drawings are based on 20 °C, 1000 motion load cycles and max. permissible pressure pulsation of 10% of the permissible operating pressure. Each expansion joint is provided with comprehensive assembly and operating instructions.

Each expansion joint is supplied with detailed installation and operating instructions.

INSPECTION AND MAINTENANCE

- The operator must ensure that the expansion joints are freely accessible so that visual inspections can be carried out at regular intervals.
- Avoid using aggressive chemicals to clean the pipe system. Please observe the resistance to media.
- Check the expansion joints for flawless condition according to valid standards. In the case of damage such as scratches, surface cracks or irregular deformation, please contact our Technical Consultation Service. Repairs to the expansion joints are not permitted.

INSTRUCTIONS FOR STEEL EXPANSION JOINTS AT PUMPS

- Connect the expansion joints as close to the pump flange as possible (see Fig. E1).
- When using centrifugal pumps for pumping abrasive media, the expansion joints must not be positioned immediately on the pump fitting (suction/discharge side).
- Otherwise the expansion joints risk being damaged by the high relative speeds caused by swirling and eddying at the pump connection.
- The spacing between the pump connection and the expansion joint must be 1 to 1.5 x DN. (see Fig. E2).
- Avoid operating pumps against completely or partially closed gate valves. Also avoid cavitation as this can destroy the expansion joint in a very short time.

Fig. E1

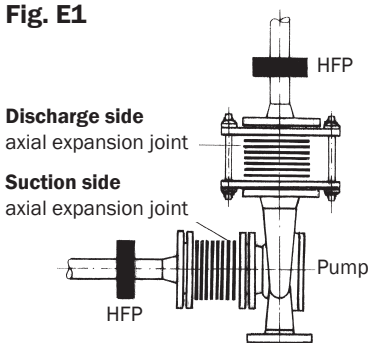

Recommendation for arranging expansion joints at pumps (normal case)

Fig. E2

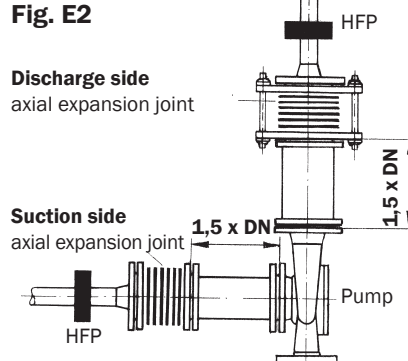

Pumping media with abrasive solid particles (special case)

DECLARATION OF CONFORMITY TO PRESSURE EQUIPMENT 2014/68/EU, ANNEX IV

We, the STENFLEX® Rudolf Stender GmbH company, declare with sole responsibility that the steel compensators to which this declaration refers conform to Directive 2014/68/EU for pressure equipment (as pressure-retaining equipment components) and meet the requirements of module H/H1 in accordance with the conformity assessment procedure.

The steel compensators that are subject to the Pressure Equipment Directive carry the CE mark and the identification number of the notified body.

TECHNICAL ANNEX

INSTALLATION AND OPERATING INSTRUCTIONS FOR RUBBER-METAL ELEMENTS

STENFLEX® rubber-metal elements can only fulfil their proper function when installed and fitted correctly. The service life is affected not only by the operating conditions but, above all by, correct installation. Rubber-metal elements are not simple pipe components but moving parts which require regular inspection.

STENFLEX® assumes no guarantee for imitation products or unauthorized modifications to original products.

INSTALLATION

- The rubber-metal elements must be kept clean and dry. When stored out in the open they must be protected from intense sunshine and weather.
- Prior to installation check the packaging and rubber metal elements for signs of damage. The product must not be installed if you detect any signs of damage whatsoever.
- Rubber-metal parts must only be fitted by authorized qualified staff. Corresponding accident prevention regulations must be observed.
- Torsional stress (twisting) to the rubber-metal elements must not occur during installation.
- Wherever possible, install rubber-metal elements so that they can be visually checked at regular intervals for possible damage.

INITIAL COMMISSIONING AND USE

- Before using the rubber-metal elements, take note of their media resistance (If in doubt please inquire).
- The operating data as stated in the data sheets or design drawings are the limits of application for use. STENFLEX® assumes no liability for damage caused by operation outside these limits. The operator is responsible for complying with these specifications.

INSPECTION AND MAINTENANCE

- The operator must ensure that the rubber metal elements are freely accessible so that visual inspections can be performed at regular intervals.
- Avoid cleaning the rubber-metal elements with aggressive chemicals. Please observe the resistance to media.
- Check the rubber-metal elements for flaws or damage at regular intervals. In the case of damage please contact our Technical Consultation Service. Repairs are not permitted.



TECHNICAL ANNEX

QUALITY MANAGEMENT

QUALITY MANAGEMENT SYSTEM

The procedures involved in development, testing, release, manufacture and final control of expansion joints are presented in our Quality Management System, in accordance with EN ISO 9001:2015.

Certified manufacturer qualifications in accordance with AD 2000-HPO and Pressure Equipment Directive (2014/68/EU) together with welding qualifications in accordance with ISO 3834-2, guarantee on-going monitoring of our production processes.

The individual components are designed and optimized at state-of-the-art 3D-CAD workstations so that customized expansion joints can be designed and supplied in addition to our standard expansion joint range.

Expansion joints are rated to the recognized TÜV-certified calculation methods (e.g., AD 2000-B13, DIN EN 14917, EJMA, etc.)

To ensure a consistently high quality standard our expansion joints are also subject to a range of practical tests:

- visual and dimension checks
- leak and pressure tests
- bursting tests
- load cycle tests
- measurement of the reaction force

International certification agencies and independent testing institutions have confirmed that STENFLEX® expansion joints meet the most demanding quality requirements.

Special product acceptance tests can also be carried out at the request of customers, either by ourselves or by external experts. Related documentation is provided accordingly.

To guarantee high safety and reliability of your system in the long-term, we also offer on-site expansion joint servicing by our experts. This is part of the STENFLEX® Quality Concept.



STENFLEX®

TECHNICAL ANNEX

CERTIFICATES AND TYPE APPROVALS

RUBBER EXPANSION JOINTS AND PIPE CONNECTORS

Agencies	American Bureau of Shipping	Bureau Veritas	DNV GL® / DNV®	NKK Nippon	Lloyd's Register of Shipping	Registro Italiano Navale	TÜV Süd - deutschland	CCS	CR	KR Korean Register	Türk Loydu
STENFLEX® Types											
Type A <ul style="list-style-type: none"> Dimensions DN 20 – DN 1000 Max. operating pressure 10 bar Max. operating temperature +90 °C Rubber grade EPDM + NBR 			 DNV				 TÜV SÜDDEUTSCHLAND T12 87 03 Rev. (Eignungsprüfung)				
Type AS (flame-proof) <ul style="list-style-type: none"> Dimensions DN 25 – DN 400 Max. operating pressure 10 bar Max. operating temperature +100 °C Rubber grade EPDM + NBR 			 DNV				 TÜV SÜDDEUTSCHLAND T12 87 03 Rev. (Eignungsprüfung)				
Type C <ul style="list-style-type: none"> Dimensions DN 300 – DN 800 Max. operating pressure 8 bar Max. operating temperature +60 °C Rubber grade EPDM 							 TÜV SÜDDEUTSCHLAND T12 87 03 Rev. (Eignungsprüfung)				
Type R <ul style="list-style-type: none"> Dimensions DN 32 – DN 300 Max. operating pressure 10 bar Max. operating temperature +90 °C Rubber grade EPDM 			 DNV				 TÜV SÜDDEUTSCHLAND T12 87 03 Rev. (Eignungsprüfung)				
Type RS (flame-proof) <ul style="list-style-type: none"> Dimensions DN 32 – DN 300 Max. operating pressure 10 bar Max. operating temperature +90 °C Rubber grade EPDM 			 DNV				 TÜV SÜDDEUTSCHLAND T12 87 03 Rev. (Eignungsprüfung)				
Type MS (flame-proof) <ul style="list-style-type: none"> Dimensions DN 65 – DN 250 Max. operating pressure 10 bar Max. operating temperature +100 °C Rubber grade EPDM + NBR 			 DNV								
Type GRV <ul style="list-style-type: none"> Dimensions DN 20 – DN 200 Max. operating pressure 10 bar Max. operating temperature +100 °C Rubber grade CR 							 TÜV SÜDDEUTSCHLAND T12 87 03 Rev. (Eignungsprüfung)				

STEEL EXPANSION JOINTS

Agencies	American Bureau of Shipping	Bureau Veritas	DNV GL® / DNV®	Registro Italiano Navale	DIN DVGW	KR Korean Register	RS Russian Maritime Register of Shipping
STENFLEX® Types							
Types SF-10, SF-11, SA-10, SA-13 <ul style="list-style-type: none"> Dimensions DN 32 – DN 150 pressure rate PN 16 Dimensions DN 200 – DN 250 pressure rate PN 10 			 DNV without SA-10 without SA-13		 Gas supply SF-10 without 250	 only SF-10	 only SF-10 SF-11
Types SF-23, SA-23 <ul style="list-style-type: none"> Dimensions DN 50 – DN 250 pressure rate PN 6 					 Gas supply		
Types SF-20, SF-21, SA-20 <ul style="list-style-type: none"> Dimensions DN 32 – DN 150 pressure rate PN 16 Dimensions DN 32 – DN 150 pressure rate PN 10 			 DNV only SF-20		 Gas supply without SA-20		
Type SG-11 <ul style="list-style-type: none"> Dimensions DN 15 – DN 50 pressure rate PN 16 					 Gas supply		

Other type approval/suitability tests on request.

TECHNICAL ANNEX

FLANGE CONNECTION DIMENSIONS PN 6, PN 10 AND PN 16 IN ACCORDANCE WITH EN 1092

DN	PN 6				PN 10				PN 16			
	Ø D Flange outer Ø mm	Ø K Pitch circle Ø mm	No. of holes	Ø d ₂ Hole Ø mm	Ø D Flange outer Ø mm	Ø K Pitch circle Ø mm	No. of holes	Ø d ₂ Hole Ø mm	Ø D Flange outer Ø mm	Ø K Pitch circle Ø mm	No. of holes	Ø d ₂ Hole Ø mm
15	80	55	4	11	95	65	4	14	95	65	4	14
20	90	65	4	11	105	75	4	14	105	75	4	14
25	100	75	4	11	115	85	4	14	115	85	4	14
32	120	90	4	14	140	100	4	18	140	100	4	18
40	130	100	4	14	150	110	4	18	150	110	4	18
50	140	110	4	14	165	125	4	18	165	125	4	18
65	160	130	4	14	185	145	8	18	185	145	8	18
80	190	150	4	18	200	160	8	18	200	160	8	18
100	210	170	4	18	220	180	8	18	220	180	8	18
125	240	200	8	18	250	210	8	18	250	210	8	18
150	265	225	8	18	285	240	8	22	285	240	8	22
175*	295*	255*	8*	18*	315*	270*	8*	22*	315*	270*	8*	22*
200	320	280	8	18	340	295	8	22	340	295	12	22
250	375	335	12	18	395	350	12	22	405	355	12	26
300	440	395	12	22	445	400	12	22	460	410	12	26
350	490	445	12	22	505	460	16	22	520	470	16	26
400	540	495	16	22	565	515	16	26	580	525	16	30
450	595	550	16	22	615	565	20	26	640	585	20	30
500	645	600	20	22	670	620	20	26	715	650	20	33
600	755	705	20	26	780	725	20	30	840	770	20	36
650*	800*	760*	24*	26*	840*	785*	24*	30*	880*	805*	24*	36*
700	860	810	24	26	895	840	24	30	910	840	24	36
750*	925*	870*	24*	26*	965*	900*	24*	30*	985*	900*	24*	29*
800	975	920	24	30	1015	950	24	33	1025	950	24	39
900	1075	1020	24	30	1115	1050	28	33	1125	1050	28	39
1000	1175	1120	28	30	1230	1160	28	36	1255	1170	28	42
1100*	1290*	1230*	28*	33*	1345*	1270*	32*	36*	1370*	1280*	28*	48*
1200	1405	1340	32	33	1455	1380	32	39	1485	1390	32	48
1300*	1520*	1450*	32*	36*	1565*	1485*	32*	42*	1585*	1490*	36*	48*
1400	1630	1560	36	36	1675	1590	36	42	1685	1590	36	48
1500*	1730*	1660*	36*	36*	1795*	1705*	36*	48*	1810*	1705*	36*	56*
1600	1830	1760	40	36	1915	1820	40	48	1930	1820	40	56
1700*	1940*	1865	40*	39*	2015*	1920*	44*	48*	2030*	1920*	44*	56*
1800	2045	1970	44	39	2115	2020	44	48	2130	2020	44	56
1900*	2155*	2075*	44*	42*	2220*	2125*	48*	48*	2240*	2125*	44*	62*
2000	2265	2180	48	42	2325	2230	48	48	2345	2230	48	62
2100*	2375*	2285*	48*	42*	2440*	2335*	48*	56*	—	—	—	—
2200	2475	2390	52	42	2550	2440	52	56	2555*	2440*	52*	62*
2300*	—	—	—	—	2650*	2545*	56*	56*	—	—	—	—
2400	2685	2600	56	42	2760	2650	56	56	2765*	2650*	56*	62*
2500*	2795*	2705*	56*	48*	2860*	2750*	56*	56*	2865*	2750*	60*	62*
2600	2905	2810	60	48	2960	2850	60	56	2965*	2850*	60*	62*
2800	3115	3020	64	48	3180	3070	64	56	—	—	—	—
3000	3315	3220	68	48	3405	3290	68	62	—	—	—	—
3200	3525	3430	72	48	—	—	—	—	—	—	—	—
3400	3735	3640	76	48	—	—	—	—	—	—	—	—
3600	3970	3860	80	56	—	—	—	—	—	—	—	—

*Dimensions not rated to standard

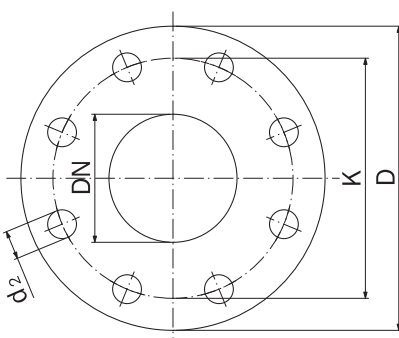

The number of screw holes for every flange is divisible by 4.

For pipes and fittings, the screw holes must be placed in such a way as to be clear of the horizontal and vertical axes.

TECHNICAL ANNEX

FLANGE CONNECTION DIMENSIONS PN 25 IN ACCORDANCE WITH EN 1092 ANSI 150 LBS AND 300 LBS • SAE 3000 PSI

DN mm	DN Zoll	ANSI 150 LBS				ANSI 300 LBS			
		Ø D Flange outer Ø mm	Ø K Pitch circle Ø mm	No. of holes	Ø d ₂ Hole Ø mm	Ø D Flange outer Ø mm	Ø K Pitch circle Ø mm	No. of holes	Ø d ₂ Hole Ø mm
15	0.50"	88.9	60.3	4	15.9	95.3	66.7	4	15.9
20	0.75"	98.4	69.9	4	15.9	117.5	82.6	4	19.1
25	1"	108.0	79.4	4	15.9	123.8	88.9	4	19.1
32	1.25"	117.5	88.9	4	15.9	133.4	98.4	4	19.1
40	1.50"	127.0	98.4	4	15.9	155.6	114.3	4	22.2
50	2"	152.4	120.7	4	19.1	165.1	127.0	8	19.1
65	2.50"	177.8	139.7	4	19.1	190.5	149.2	8	22.2
80	3"	190.5	152.4	4	19.1	209.5	168.3	8	22.2
100	4"	228.6	190.5	8	19.1	254.0	200.0	8	22.2
125	5"	254.0	215.9	8	22.2	279.4	235.0	8	22.2
150	6"	279.4	241.3	8	22.2	317.5	269.9	12	22.2
175	7"	311.2*	269.9*	8*	22.2*	—	—	—	—
200	8"	342.9	298.4	8	22.2	381.0	330.2	12	25.4
250	10"	406.4	362.0	12	25.4	444.5	387.4	16	28.6
300	12"	482.6	431.8	12	25.4	520.7	450.9	16	31.8
350	14"	533.4	476.3	12	28.6	584.2	514.4	20	31.8
400	16"	596.9	539.8	16	28.6	647.7	571.5	20	34.9
450	18"	635.0	577.9	16	31.8	711.2	628.7	24	34.9
500	20"	698.5	635.0	20	31.8	774.7	685.8	24	34.9
600	24"	812.8	749.3	20	34.9	914.4	812.8	24	41.3
650	26"	870.0	806.5	24	34.9	971.6	876.3	28	44.5
700	28"	927.1	863.6	28	34.9	1035.1	939.8	28	44.5
750	30"	984.3	914.4	28	34.9	1092.2	997.0	28	47.6
800	32"	1060.5	977.9	28	41.3	1149.4	1054.1	28	50.8
850	34"	1111.3	1028.7	32	41.3	1206.5	1104.9	28	50.8
900	36"	1168.4	1085.9	32	41.3	1270.0	1168.4	32	54.0
950	38"	1238.3	1149.4	32	41.3	1168.4	1092.2	32	41.3
1000	40"	1289.1	1200.2	36	41.3	1238.3	1155.7	32	44.5
1050	42"	1346.2	1257.3	36	41.3	1289.1	1206.5	32	44.5
1100	44"	1403.4	1314.5	40	41.3	1352.6	1263.7	32	47.6
1150	46"	1454.2	1365.3	40	41.3	1416.1	1320.8	28	50.8
1200	48"	1511.3	1422.4	44	41.3	1466.9	1371.6	32	50.8
1250	50"	1568.5	1479.6	44	47.6	1530.4	1428.8	32	54.0
1300	52"	1625.6	1536.7	44	47.6	1581.2	1479.6	32	54.0
1350	54"	1682.8	1593.9	44	47.6	1657.4	1549.4	28	60.3
1400	56"	1746.3	1651.0	48	47.6	1708.2	1600.2	28	60.3
1450	58"	1803.4	1708.2	48	47.6	1759.0	1651.0	32	60.3
1500	60"	1854.2	1759.0	52	47.6	1809.8	1701.8	32	60.3
1700	66"	2032.0	1930.4	52	47.6	—	—	—	—
1800	72"	2197.1	2095.5	60	47.6	—	—	—	—
2000	78"	2362.2	2260.6	64	54.0	—	—	—	—
2100	84"	2533.7	2425.7	64	54.0	—	—	—	—
2300	90"	2705.1	2590.8	68	61.9	—	—	—	—
2400	96"	2876.6	2755.9	68	61.9	—	—	—	—

*Dimensions not rated to standard

DN mm	SAE 3000 PSI				
	Ø d Hole Ø mm	A Hole spacing mm	B Hole spacing mm	C flange outer dimension mm	D flange outer dimension mm
40	13	70	35.7	94	75
50	13	78	43.0	102	86
65	13	89	51.0	116	98
80	17	106	62.0	134	120
100	17	130	78.0	162	146
125	17	152	92.0	190	170

DN	PN 25			
	Ø D Flange outer Ø mm	Ø K Pitch circle Ø mm	No. of holes	Ø d ₂ Hole Ø mm
15	95	65	4	14
20	105	75	4	14
25	115	85	4	14
32	140	100	4	18
40	150	110	4	18
50	165	125	4	18
65	185	145	8	18
80	200	160	8	18
100	235	190	8	22
125	270	220	8	26
150	300	250	8	26
175*	330*	280*	12*	26*
200	360	310	12	26
250	425	370	12	30
300	485	430	16	30
350	555	490	16	33
400	620	550	16	36
450	670	600	20	36
500	730	660	20	36
600	845	770	20	39
700	960	875	24	42
800	1085	990	24	48
900	1185	1090	28	48
1000	1320	1210	28	56

*Dimensions not rated to standard

DN	PN 40			
	Ø D Flange outer Ø mm	Ø K Pitch circle Ø mm	No. of holes	Ø d ₂ Hole Ø mm
20	105	75	4	14
25	115	85	4	14
32	140	100	4	18
40	150	110	4	18
50	165	125	4	18
65	185	145	8	18
80	200	160	8	18
100	235	190	8	22
125	270	220	8	26
150	300	250	8	26
200	375	320	12	30
250	450	385	12	33
300	515	450	12	33

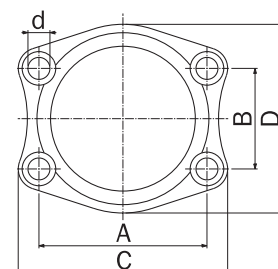

Flange to SAE standard

TECHNICAL ANNEX

FLANGE CONNECTION DIMENSIONS / ROUND FLANGES FOR EXHAUST PIPES DIN 86044

DN	DIN 86044-1			
	Ø D Flange outer Ø mm	Ø K Pitch circle Ø mm	No. of holes	Ø d ₂ Hole Ø mm
80	-	-	-	-
100	-	-	-	-
125	-	-	-	-
150	-	-	-	-
160	-	-	-	-
200	320	280	8	18
250	375	335	12	18
300	440	395	12	22
(315)	-	-	-	-
350	490	445	12	22
355	-	-	-	-
400	540	495	16	22
450	595	550	16	22
500	645	600	20	22
(550)	703	650	20	22
560	-	-	-	-
600	754	700	20	22
(630)	-	-	-	-
(650)	805	750	20	22
700	856	800	24	22
710	-	-	-	-
(750)	907	850	24	22
800	958	900	24	22
(850)	1010	950	28	22
900	1060	1010	28	22
(950)	1110	1060	28	22
1000	1162	1110	32	22
1100	1266	1210	32	22
1120	-	-	-	-
1200	1366	1310	36	22
(1250)	-	-	-	-
1300	1466	1410	40	22
1400	1566	1510	40	22
1500	1666	1610	44	22
1600	1766	1710	48	22
1700	1866	1810	48	22
1800	1966	1910	52	22
1900	2066	2010	56	22
2000	2166	2110	56	22
2100	2266	2210	60	22
2200	2366	2310	64	22
2300	2466	2410	64	22
2400	2566	2510	68	22
2500	2666	2610	72	22
2600	2766	2710	72	22
2700	2866	2810	76	22
2800	2966	2910	80	22
2900	3066	3010	80	22
3000	3166	3110	84	22

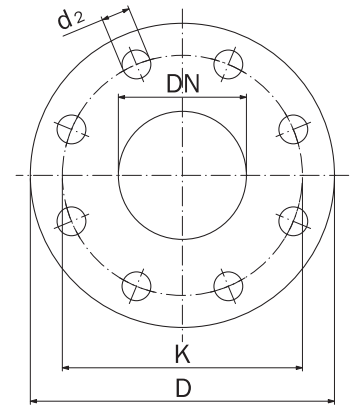

For pipes and fittings the screw holes must be placed in such a way as to be clear of the horizontal and vertical axes.

TECHNICAL ANNEX

COMPARISON AND CONVERSION TABLES

COMPARISON TABLE OF INTERNATIONAL MATERIAL DESIGNATIONS

Europe		Germany		France	United Kingdom	USA	max. tol. temperature	
Designation EN	Material No. EN	Material No. DIN EN	old DIN	AFNOR	B.S.	AISI SAE ASTM	min.	max.
GJMW-400-5	JM1030	0.8040	GTW-40-05					+350 °C
S 235 JR	1.0038	1.0038	RSt 37-2	E 24-2	Fe 360 B	A 283 Gr. C		+300 °C
P 235 TR 1	1.0254	1.0254	St 37.0	E 24-2 NE	Fe 360 BFU	A 570 Gr. 36	-10 °C	+300 °C
P 235 G1 TH	1.0305	1.0305	St 35.8I				-10 °C	+300 °C
	1.0401	1.0401	C 15	C 18	080 A 15	M 1015		+300 °C
P 235 GH	1.0345	1.0345	H I					+400 °C
P 265 GH	1.0425	1.0425	H II	AP	1501			+400 °C
P 250 GH	1.0460	1.0460	C 22.8				-10 °C	+450 °C
S 355 J2	1.0577	1.0577	St 52-3N	E 36-3	Fe 510 D1	A 572 Gr. 50		
X 5 CrNi 18-10	1.4301	1.4301	X 5 CrNi 18-10	E 36-4	FF	1024, 1524	-10 °C	+300 °C
X 8 CrNiS 18-9	1.4305	1.4305	X 8 CrNiS 18-9	Z 4 CN 19-10	304 S 11	304	-196 °C	+550 °C
X 2 CrNiMo 17-12-2	1.4404	1.4404	X 2 CrNiMo 17-12-2	Z 8 CNF 18-09	303 S 22	303		+400 °C**
X 6 CrNiTi 18-10	1.4541	1.4541	X 6 CrNiTi 18-10	Z 2 CND 17-12	316 S 11	316 L	-196 °C	+550 °C**
X 6 CrNiMoTi 17-12-2	1.4571	1.4571	X 6 CrNiMoTi 17-12-2	Z 6 CNT 18-10	321 S 31	321	-196 °C	+550 °C*
X 15 CrNiSi 20-12	1.4828	1.4828	X 15 CrNiSi 20-12	Z 6 CNDT 17-12	320 S 18	316 Ti	-196 °C	+550 °C*
X 12 CrNiTi 18-9	1.4878		X 12 CrNiTi 18-9	Z 9 CN 24-13	309 S 24	309	-196 °C	+550 °C*
X 8 CrNiTi 18-10		1.4878	X 8 CrNiTi 18-10	Z 6 CNT 18-10	321 S 51	321		+800 °C
X 1 NiCrMoCu 25-20-5		1.4539	X 1 NiCrMoCu 25-20-5			904 L		+550 °C
16 Mo 3	1.5415	1.5415	16 Mo 3; 15 Mo 3	15 D 3	1503-243 B	4017	-10 °C	+500 °C
				42 CD 4				
42CrMo 4	1.7225	1.7225	42CrMo 4	42 CrMo 4	708 A 42	4140, 4142		+450 °C
21CrMoV 5-7	1.7709	1.7709	21CrMoV 5-7					+540 °C
		2.4858	NiCr 21 Mo					+450 °C

*up to +400 °C: resistant to intercrystalline corrosion. **up to +300 °C: resistant to intercrystalline corrosion

CHANGES IN TEMPERATURE/LENGTH OF VARIOUS MATERIALS

Pipe material	Change in length ΔL at temperature change ΔT from 0 °C to ΔL					
	+100 °C	+200 °C	+300 °C	+400 °C	+500 °C	+600 °C
1.0038 (S235JR)	1.11	2.42	3.87	-	-	-
1.0305 (P235G1TH)	1.23	2.60	4.05	5.60	-	-
1.4541	1.60	3.40	5.10	7.20	9.00	11.1
1.4404	1.65	3.50	5.25	7.40	9.25	11.4
Kupfer	1.68	3.55	5.30	7.50	9.50	11.6
Aluminium	2.38	4.90	7.65	10.60	13.70	17.0
Polypropylen	11.0	-	-	-	-	-

The table indicates the mean change in length ΔL in mm for 1 m pipe length.

PRESSURE CONVERSION TABLE

Unit Abbreviation	Pa=N/m ²	bar =10 ⁵ N/m ²	at =Kp/cm ²	m wc	mm HG =Torr	lbf / in ² = psi	lbf / ft ²
Pascal: 1 Pa=1 N/m ²	1	0.00001	0.00001	0.0001	0.0075	0.00014	0.02089
bar: 1 bar=10 ⁵ N/m ²	100 000	1	1.0197	10.197	750.062	14.504	2088.54
Technical atmosphere: 1 at=1 Kp/cm ²	98066.5	0.98067	1	10	735.559	14.223	2.0482
Meter water column: 1 m wc	9806.65	0.09807	0.1	1	73.556	1.4223	204.816
Millimeter mercury column: 1 mm Hg=1 Torr	133.322	0.00133	0.00136	0.0136	1	0.0193	2.785
Pound-force per square inch: 1 lbf/in ² (psi)	6894.76	0.06895	0.0703	0.7031	51.715	1	144.0
Pound-force per square foot: 1 lbf/ft ²	47.880	0.00048	0.00048	0.00048	0.35913	0.0694	1

TECHNICAL ANNEX

GLOSSARY

A

Adjustment force

The force that is required to move a flexible pipe connection by a specific amount under specified conditions.

Angular movement

The terms "axial, lateral and angular" are frequently used to denote directions of movement in the context of expansion joints.

Axial compression force

The axial compression force is the longitudinal force resulting from the internal overpressure.

Axial movement

The movement of a pipeline element in the direction of the longitudinal axis of the pipe.

B

Bellows

The bellows is the flexible and pressure-tight base element of an expansion joint.

Burst pressure

The pressure at which a flexible pipe connection is no longer impermeable

C

CIIR

CIIR = chlorine-isobutene-isoprene rubber (trade name: "butyl"). Type of rubber suitable and approved for drinking water. STENFLEX colour designation: "white".

Compression

The shortening of a flexible pipe connection due to movement absorption.

Connecting parts

The parts of a flexible pipe connection with which a connection is established to the pipeline to be connected, e.g. flanges, welded ends, union nuts etc.

Corner-compensated expansion joint

An expansion joint that is installed at a 90° bend (corner)

of a pipeline and that – due to its design – can absorb axial and lateral movements from both pipe legs without stressing the fixed points with reaction forces.

Corrugated hose

A metal hose with a flexible element that consists of a sequence of individual, straight shafts or a single, helically moving shaft.

CR

CR = polychloroprene (trade name: "neoprene")

D

DIN 4809 Part 1 & 2

DIN 4809: Expansion joints made from elastomer composites (rubber expansion joints) for water heating systems; for a maximum operating temperature of 100°C and a permitted positive operating pressure of 10 bar. See STENFLEX certificate.

DVGW

Deutscher Verein des Gas- und Wasserfaches (German Technical and Scientific Association for Gas and Water)

E

Effective bellows cross-section

The cross-sectional area of an expansion joint bellows that produces the hydraulic reaction force together with the internal pressure present.

EPDM

EPDM = ethylene propylene diene monomer rubber. Heat and weather-resistant material with particular resistance to highly oxidising media as well as chemicals (not oil-resistant). STENFLEX colour designation: "orange".

Expansion joint

In addition to hoses, expansion joints are the most frequently used flexible pipe connections. They are available with nominal diameters of a few millimetres up to several metres, for pressures from a vacuum up to several 100 bar and for an incredibly wide range of movements. The wide range of different designs makes expansion joints more versatile than any other flexible pipe connection. The main criterion for determining which of the different designs to use is the direction in which the expansion joint can absorb movement.

TECHNICAL ANNEX

GLOSSARY

Expansion loop; lyra-shaped design

In contrast to flexible pipe connections, pipe expansion bends do not have a flexible element; instead, they consist of a simple, rigid pipe that is sufficiently elastic to enable movements to be absorbed as a result of its curved and protruding form.

F

Fixed point

A structural device or bracket that anchors a pipeline in place at a particular point.

G

Guide bearing

A structural device or bracket that enables a pipeline to be shifted longitudinally without permitting any lateral displacement.

Guide pipe

A component that is designed to prevent an axial expansion joint from making any lateral or angular movement.

Guide sleeve

An accessory fitted inside of an expansion joint, which channels the respective medium through the expansion joint without any flow losses occurring at the bellows shafts and without the bellows shafts being initiated via damaging natural vibrations.

H

Hose

A flexible pipe connection with which a very large lateral and angular movement can be absorbed as it is available in almost any overall length.

I

Installation length

The length of a flexible pipe connection after being installed in a pipeline.

L

Lateral movement

The movement of a pipeline element transverse to the longitudinal axis of the pipe.

Load cycle / load change

A non-recurring axial, angular or torsional movement cycle from a defined starting point.

M

Movement absorption

The spatial shifting of a pipeline section that absorbs a flexible pipe connection.

N

NBR

NBR = acrylonitrile butadiene rubber

Type of rubber for media containing mineral oil. Colour designation: "red".

Number of cycles to failure

The number of cycles at which a flexible pipe connection loses its pressure tightness due to material fatigue.

O

Operating pressure

The pressure present in a pipeline system during operation.

Operating temperature

The temperature in a pipeline system during operation.

Overall length

The length of a flexible pipe connection when it is not under load or pre-tensioned.

P

Pressure Equipment Directive

Directive 2014/68/EU of the European Parliament and of the Council of 15 May 2014 on the harmonisation of the laws of the Member States relating to the making available on the market of pressure equipment (new version) was published in the Official Journal of the European Union L 189 of 27 June 2014, page 164. It supersedes the previous Pressure Equipment Directive 97/23/EC on 19 July 2016.

Pressure stage

Standardised nominal pressure for which a flexible pipe connection has been dimensioned.

Pressure-compensated expansion joint

An untensioned expansion joint that does not develop any hydraulic reaction force in the pipeline as a result of its design and that, in contrast to a tensioned expansion joint, permits axial movement absorption.

Pretensioning

An installation condition of an expansion joint whereby the expansion joint is not installed with its untensioned overall length but rather with a pre-tensioned installation length. It is used in order to enable a bigger movement to be absorbed with an expansion joint, provided the respective movement does not take place in the opposite direction to the pretensioning direction.

PTFE

Heat and weather-resistant type of material with outstanding chemical resistance to aggressive media.

R**Reaction force, axial**

A hydraulic force occurring from internal pressure and taking effect in the longitudinal direction of the pipe. It corresponds to the product of the effective cross-section of a flexible pipe connection and the internal pressure.

Reinforcing material

Rubber bellows have a three-layered wall structure:

- Inner layer (core) made from a media-resistant rubber mixture
- Intermediate layer made from a rubber mixture with reinforcing materials
- Outer layer (top layer) made from a weather-resistant rubber mixture.

Rubber expansion joint

Expansion joint with a rubber bellows as a flexible element.

Rubber-metal pipe connector (GRV)

Vibration and noise damper

Rubber body with fully embedded metal flanges.

S**Shaft**

A geometry unit of an expansion-joint bellows that gives the bellows its level of flexibility and thereby enables movement to be absorbed.

Spring rate

A variable that describes how much force must be applied in order to pre-tension a flexible pipe connection by a defined movement unit.

Steel expansion joint

Expansion joint with steel bellows as a flexible element.

T**Tension rods**

Tension rods refer to the tensioning elements of lateral expansion joints with threaded rods.

Tensioning elements are used on lateral and angular expansion joints. The tensioning elements absorb the axial reaction forces caused by the internal pressure.

Tensioning unit

A functional unit of an expansion joint that generally absorbs the hydraulic reaction force of the bellows and only permits defined types of movement, such as an angular movement around an axis, in accordance with its design. When dimensioning a tensioning unit, any potential additional forces from the pipeline also need to be taken into account.

Thermal expansion

Flexible pipe connections are required for a number of reasons, including the fact that pipelines are not as rigid and static as they appear at first glance. As pipelines, like any other material, are subject to basic physical laws, they become "bigger" when the temperature increases and "smaller" when the temperature decreases. The technical expression for this is heat expansion.

Type examination

E.g. type approvals; performance tests.

V**Vacuum supporting ring**

Depending on the respective requirements, type of expansion joint and nominal width, vacuum resistance can be increased for some expansion joints by using vacuum supporting rings.

Inquiry Company: _____ Phone: _____

Order Name/department: _____ Fax: _____

 Address/P.O. Box: _____ e-mail: _____

 Postcode/Town: _____ Date: _____

STEEL EXPANSION JOINTS

Type/Designation: _____

Quantity: _____ each DN: _____ Structural length (BL): _____ mm

Flow medium: _____	Bellows material: _____
Design pressure: _____ bar (excess-pressure)	Rating temperature: _____ °C
Operating pressure: _____ bar (excess-pressure)	Operating temperature: _____ °C
Test pressure: _____ bar (excess-pressure)	Max. temperature (briefly): _____ °C
Vacuum: _____ bar abs.	Flow velocity: _____ m/s
Pressure pulses: <input type="checkbox"/> yes <input type="checkbox"/> no	Simultaneous movement: _____
Axial travel: +/- _____ mm	_____
Lateral travel: +/- _____ mm	_____
Angular angle: +/- _____ degrees	
No. of load cycles: _____	<input type="checkbox"/> pre-tensioned
<input type="checkbox"/> Schwingungen Amplitude: _____ mm	Frequency: _____ Hz

Flange connection

Flange standard/pressure rate: _____ Corrosion protection: _____

Non-standardized flange dimensions → Outer diameter D _____ mm

Material: _____ Pitch circle diameter K _____ mm

Connection as per enclosed specification No. of holes n _____ each

 Hole diameter d₂ _____ mm

Pipe connection / welding end

Pipe dimensions → Outer diameter D _____ mm

 Wall thickness s _____ mm

Material: _____ Corrosion protection: _____

Threaded connection Female thread _____ Male thread _____

Restraints to absorb the reaction force

External restraints with tie rods (lateral expansion joint) Hinge restraints (angular expansion joint)

Accessories Protective tube Internal guide sleeve

Tests / Certificates / Regulations

Acceptance test: _____ Certificates: _____

Pressure test: _____ Regulations: _____

SWIVEL JOINTS

Please copy, fill and fax

Fax No. +49 40 529 03 200

 Enquiry Order

Application:					
Medium:					
Quantity					
Type					
Form					
Material					
FLANGE					
DN					
Flange drilling					
WELDING END					
Pipe dimension Ø x s (mm)					
THREADED CONNECTION					
Dimension: female thread					
Dimension: male thread					
working temperature °C					
working pressure bar					
test pressure bar					
Certificate 3.1 B acc. to EN 10204					
Inspection by TÜV or other					
Date of delivery:					
Delivery address: (if other than purchaser)					
Enquiry Ref.:				Client's No.:	
Project:					
Company:					
Name:			Dept.:		
Address:			Phone/Fax:		
City:					
Date:			Sign:		

INTERNATIONAL

HEADQUARTERS, SUBSIDIARIES AND AGENCIES

DE

STENFLEX® Rudolf Stender GmbH

Robert-Koch-Str. 17
22851 Norderstedt
Deutschland
☎ +49 40 529 03 - 0
✉ info@stenflex.com
☎ +49 40 529 03 - 200

FR

STENFLEX® S.a.r.l.

Z.I. les Chanoux
38, rue des Frères Lumière
F - 93330 Neuilly sur Marne
☎ +33 1 43 00 48 37
✉ info@stenflex.com
☎ +33 1 43 00 48 89

ES

STENFLEX® SA

Poligono Industrial el Praderon
Calle Tanger no. 6
E - 28700 San Sebastián de los Reyes
(MADRID)
☎ + 34 91 663 78 - 96
✉ info@stenflex.com
☎ + 34 91 663 69 - 35

AE / OM / SA

**Al Jimal Mechanical Equipment
Trading**

Office No. 10, Block A,
TAWJEEH/ ARAMEX
Musaffah M-09, Plot 38,39,
Abu Dhabi, U.A.E
☎ + 971 2 555 8664
✉ jjim@aljimal.com

CN

HK Haichuan International Ltd.

Marine Technology
HK Haichuan Int'l Limited
Room 1106, Building A, Biyun Mansion
No. 289 Zheqiao Road, Pudong, CN -
Shanghai
☎ +86-21-6168-2673
✉ shanghai@haichuanhk.com
☎ +86-21-6168-2675

FI

INBUX Oy Ab

Holkkitie 14 C 10
FIN - 00880 Helsinki
☎ + 35 89 68 40 - 700
✉ mail@inbux.fi

AT

KSB Österreich GesmbH

Industriezentrum NÖ-Süd, Str. 10,
Objekt 45, A - 2355 Wiener Neudorf
☎ + 43 1 910 30 - 0
✉ info.austria@ksb.com

CN

**Shanghai Hang Ou Mechanical and
Electrical Equipment Co.,Ltd.**

Industrial Applications
Room 905, Bldg. No.1, Guoson Centre
Lane 388, Zhongjiang Road, Putuo
CN - Shanghai
☎ 0086/21/51085161
✉ pur622@shhangou.com
☎ 0086/21/51870910

GB / IE

Engineered Products & Solutions LTD

Unit 15 Cedar Court, Halesfield 17
GB - Telford TF7 4PF
☎ + 44 19 52 68 02 13
✉ sales@epands.com

AU / NZ

Bray Controls Pacific-NSW

Unit 4, Level 2, 7 Grosvenor Place
Brookvale NSW 2100 Australia
☎ + 61 2 8968-9363
✉ bns.w.sales@bray.com

CZ

**OBZAHO Obchodní zastoupení
Hovorková, s.r.o.**

Gorkého 1577
CZ - 530 02 Pardubice
☎ + 420 466 304 - 133
✉ info@obzaho.com

GR

WILO Hellas A.G.

Ag. Athanasiou Str. 80
GR - 14569 Anixi (ATTICA)
☎ + 30 210 62 48 - 300
✉ wilo.info@wilo.gr

BE

Hanwel Belgium N.V

Industriezone T.T.S. - Zone B
Winninglaan 15, B - 9140 Temse
☎ + 32 03 711 03 - 53
✉ info@hanwel.be

DK

HNC Group A/S

Industrivej 2
DK - 4241 Vemmelev
☎ 45 70 13 23 00
✉ sales@saniflow.dk

IL

Mendelson - S. Bar LTD

11 Hagvura St
IL - 28101 Kiriya
☎ (972) 48 46 49 81
✉ meitlisy@mlsbar.com

INTERNATIONAL

HEADQUARTERS, SUBSIDIARIES AND AGENCIES

IN**Ras Tek Pvt.Ltd**

Mumbai Office
IN - 400701 Navi Mumbai
☎ + 91 022 7101 2021
✉ sales@ras-tek.com

LT**JSC EKOBANA**

Pergales g. 33-A
LT - 2041 Vilnius
☎ + 370 5 249 18 - 06
✉ sav@ekobana.lt

RS**MF Seals d.o.o.**

Kruzni Put 40, Lestane-industry place
RS - 11309 Beograd
☎ +38-11-8036314
☎ +38-11-8036315

IN**New Delhi Office**

IN - 201301 Noida, Uttar Pradesh
☎ + 91 120 425 5040
✉ sales@ras-tek.com

MX**CAMPEX S.A.**

Alcanfores n° 49 - 8
Col. Las Aguilas
01710 Mexico D.F.
☎ + 55 55 93 - 69 26
✉ info@campex.com.mx

SE**AXEL LARSSON AB**

Box 805
Trucksvägen 12 i Upplands Väsby
S - 194 28 Upplands Väsby/Stock-
holm
☎ + 46 (0) 10 455 97 00
✉ info@axel-larsson.se

IN**Chennai Office**

IN - Nagalkeni, Chromepet
Chennai-44
☎ + 91 44 2538 7371
✉ sales@ras-tek.com

NL**HANWEL B.V.**

Jan Tinbergenstraat 209
NL - 7559 SP Hengelo
☎ + 31 (0) 74-265 00 00
✉ verkoop@hanwel.com

SG / ASEAN**Emmbee Pacific PTE Ltd.**

21 Toh Guan Road East
#09-02 Toh Guan Centre
SG - 608609
☎ + 65 62 75 89 - 33
✉ info@emmbee.com

IT**KSB ITALIA S.p.A.**

Via Massimo d'Azeglio 37
I - 20049 Concorezzo (MI)
☎ + 39 39 604 80 - 25
✉ anna.vimercati@ksb.com

NO**ROLF LYCKE AS**

Arnstein Arnebergsvei 28
N - 1366 Lysaker/Oslo
☎ + 47 23 24 42 - 00
✉ oslo@rolflycke.com

TR**HİPAŞ Hidrolik Pnömatik
San. ve Tic. A.Ş.**

Esensehir Mahallesi, IMES Sanayi Sitesi,
C blok 308 Sokak, No 16
TR - 34776 Istanbul - Y.Dudullu - Umraniye
☎ + 90 212 251 40 - 05
✉ info@hipashidrolik.com

JP**Tokyo Sangyo Co., Ltd**

No2. Uyeno Bldg.4F 3-7-18 Kohoku-ku
Shin-Yokohama
JP - 222-0033, Yokohama City
☎ +81-45-474-2206
☎ +81-45-474-2210

PL**Spetech Sp. z. o. o.**

ul. Szyprów 17
PL - 43 382 Bielsko - Biala 14
☎ + 48 33 818 41 - 33
✉ spetech@spetech.com.pl

US**MSSH Motor-Services Hugo Stamp, Inc.**

3190 SW 4th Avenue
US - FL 33315, Fort Lauderdale
☎ +1-954-7633660
✉ parts@mshs.com
☎ +1-954-7632872