

# RUBBER EXPANSION JOINT TYPE R-1

LENGTH 130 MM

## UNIVERSAL EXPANSION JOINT DN 25 – DN 300

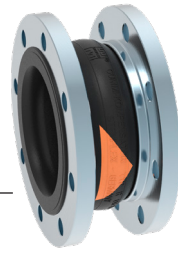

### STRUCTURE TYPE R-1 / RUBBER BELLOWS PN 16

- Universal expansion joint consisting of a rubber bellows and rotatable flanges
- Flat-convoluted molded bellows in various rubber grades
- Synthetic fibre reinforcement
- Wire-reinforced self-sealing rubber rim
- Electrical impedance  $10^3$  to  $10^6$  Ohm (DIN IEC 93, VDE 0303-30)

Rubber grade*	EPDM	NBR	CIIR
Colour code	orange	red	white
Possible uses	Hot water, acids, lyes	hydrocarbon containing liquids	Drinking water

\*Check or inquire about the resistance of the rubber grade to temperature and medium.

Technical design	
Max. perm. operating pressure	16 bar*
Max. perm. temperature	+100 °C
Bursting pressure	≥ 48 bar
Vacuum operation	DN 25 – 50 without vacuum supporting ring, DN 65 – 300 with vacuum supporting ring

Max. operating pressure to be set 30 % lower for shock loads.

\*Please consider a decrease of pressure due to temperature (see technical annex).

### FLANGES / VERSIONS

- Rotatable flanges with stabilizing collar
- Flange drilling for through bolts, DN 25 with Drill holes
- Special machined groove for rubber rim

	Standard	Others
Dimensions	EN 1092	ANSI, BS etc. Connection dimensions see technical annex page 213 – 215
Materials	1.0038 (S235JR)	1.4541, 1.4571
Corrosion protection	electrogalvanized	hot-dip galvanized, special varnish, special coating, etc.

### NOTE

Please comply with the general technical instructions regarding reaction force, moving force, fixed point load, installation instructions etc.

Subject to technical alterations and deviations resulting from the manufacturing process.

### APPLICATIONS

- for reducing thermal and mechanical tension in pipes and their system components, e.g.
  - pumps
  - compressors
  - engines
- for muffling vibration and noise
- for compensating axial, lateral and angular movement
- to compensate for installation inaccuracies
- as installation and dismantling aid

### CERTIFICATES

- CE (PED 2014/68/EU)
- Bureau Veritas
- DNV GL® / DNV®
- Lloyd's Register of Shipping
- TÜV Süd (KTA)
- Drinking water

### ACCESSORIES

- Vacuum supporting ring
- Internal guide sleeve
- Flame-proof protective cover
- Protective hood
- Protective tube

## DIMENSIONS STANDARD PROGRAM

DN	BL	Pressure rate	Ø dj Bellows inner Ø	Ø C Raised face outer Ø	Ø E Raised face inner Ø	Ø W* Con- volution Ø	PN Flange connec- tion EN 1092	Ø D Flange outer Ø	b Flange thick- ness
	mm	bar	mm	mm	mm	mm		mm	mm
25	130	16	31 ± 3	72	39	88	16	115	16
32	130	16	31 ± 3	72	39	88	16	140	16
40	130	16	39 ± 3	81	45	96	16	150	16
50	130	16	49 ± 3	95	56	107	16	165	16
65	130	16	65 ± 3	115	72	123	16	185	18
80	130	16	77 ± 3	127	84	135	16	200	20
100	130	16	100 ± 3	151	109	160	16	220	20
125	130	16	127 ± 3	178	133	184	16	250	22
150	130	16	153 ± 3	206	161	212	16	285	22
200	130	10	202 ± 3	260	209	260	10	340	25
250	130	10	252 ± 3	313	262	313	10	395	25
300	130	10	303 ± 3	363	312	363	10	445	25

\*unpressurized

From DN 200 pressure rate 16 bar also available with flanges PN 16.  
Please contact us for further flange dimensions.

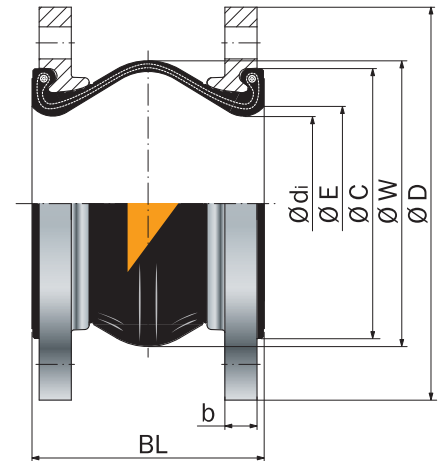

**Type R-1**

Universal expansion joint without restraint

## MOVEMENT COMPENSATION

DN	Δ ax Axial movement		Δ lat Lateral move- ment ± mm	Δ ang* Angular move- ment ± < degrees	A** Effective bellows cross sectional area at 16 bar cm <sup>2</sup>	Permissible vacuum w/o supporting ring at length BL bar absolute	Weight approx. kg
	Compression - mm	Elongation + mm					
25	35	10	15	25	8	-	2.2
32	35	10	15	25	8	0.6	3.3
40	35	10	15	25	9	0.6	3.8
50	35	10	15	25	19	0.6	4.5
65	35	10	15	25	33	0.7	5.2
80	30	10	15	20	53	0.65	7.1
100	30	10	15	15	98	0.6	8.0
125	30	10	15	15	103	0.75	10.5
150	30	10	15	10	203	0.65	12.8
200	25	10	15	7	379	0.7	18.2
250	25	10	15	6	525	0.7	23.7
300	20	10	15	5	769	0.8	30.4

\* Larger Δ ang possible for compressed installation length.

\*\*Effective bellows cross sectional area is a theoretical value.

Please inquire for simultaneous (different) movement.