

RUBBER EXPANSION JOINT TYPE R-2

LENGTH 130 MM

LATERAL EXPANSION JOINT DN 25 – DN 300

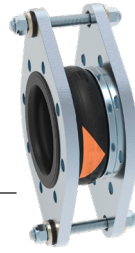

STRUCTURE TYPE R-2 / RUBBER BELLOWS PN 16

- Lateral expansion joint consisting of a rubber bellows with rotatable flanges and tie rods (external restraints) to absorb reaction force from internal pressure.
- Flat-convoluted molded bellows in various rubber grades
- Synthetic fibre reinforcement
- Wire-reinforced self-sealing rubber rim
- Electrical impedance 10^3 to 10^6 Ohm (DIN IEC 93, VDE 0303-30)

Rubber grade*	EPDM	NBR	CIIR
Colour code	orange	red	white
Possible uses	Hot water, acids, lyes	hydrocarbon containing liquids	Drinking water

*Check or inquire about the resistance of the rubber grade to temperature and medium

Technical design	
Max. perm. operating pressure	16 bar*
Max. perm. temperature	+100 °C
Bursting pressure	≥ 48 bar
Vacuum operation	DN 25 – 50 without vacuum supporting ring, DN 65 – 300 with vacuum supporting ring

Max. operating pressure to be set 30 % lower for shock loads.

*Please consider a decrease of pressure due to temperature (see technical annex).

FLANGES / VERSIONS

- Flanges with stabilizing collar and ears to carry the tie rods
- Flange drilling for through bolts, DN 25 with Drill holes
- Special machined groove for rubber rim

	Standard	Others
Dimensions	EN 1092	ANSI, BS etc. Connection dimensions see technical annex page 213 – 215
Materials	1.0038 (S235JR)	1.4541, 1.4571
Corrosion protection	electrogalvanized	hot-dip galvanized, special varnish, special coating, etc.

NOTE

Please comply with the general technical instructions regarding reaction force, moving force, fixed point load, installation instructions etc.

Subject to technical alterations and deviations resulting from the manufacturing process.

APPLICATIONS

- for reducing thermal and mechanical tension in pipes and their system components, e.g.
 - pumps
 - compressors
 - engines
- for muffling vibration and noise
- for compensating lateral movement
- to compensate for installation inaccuracies
- to compensate for ground and foundation settlement or tank settlement during filling

TIE ROD RESTRAINTS

- DN 25 – DN 150 Tie rods carried on silencing rubber sockets
- DN 200 – DN 300 Tie rods carried on spherical washers and conical seats

Materials

Standard: tie rods 8.8

Others: stainless steel

Corrosion protection

Standard: electrogalvanized

Others: hot-dip galvanized

CERTIFICATES

- CE (PED 2014/68/EU)
- Bureau Veritas
- DNV GL® / DNV®
- Lloyd's Register of Shipping
- TÜV Süd (KTA)
- Drinking water

DIMENSIONS STANDARD PROGRAM

DN	BL	Pressure rate	Ø di Bellows inner Ø	Ø C Raised face outer Ø	Ø E Raised face inner Ø	Ø W* Con-volution Ø	PN Flange connection EN 1092	Ø D Flange outer Ø	b Flange thickness	H Flange height
	mm	bar	mm	mm	mm	mm		mm	mm	mm
25	130	16	31 ± 3	72	39	88	16	115	16	210
32	130	16	31 ± 3	72	39	88	16	140	16	220
40	130	16	39 ± 3	81	45	96	16	150	16	230
50	130	16	49 ± 3	95	56	107	16	165	16	240
65	130	16	65 ± 3	115	72	123	16	185	18	260
80	130	16	77 ± 3	127	84	135	16	200	20	300
100	130	16	100 ± 3	151	109	160	16	220	20	350
125	130	16	127 ± 3	178	133	184	16	250	22	385
150	130	16	153 ± 3	206	161	212	16	285	22	420
200	130	10	202 ± 3	260	209	260	10	340	25	465
250	130	10	252 ± 3	313	262	313	10	395	25	520
300	130	10	303 ± 3	363	312	363	10	445	25	570

*unpressurized

From DN 200 higher pressure rate available on request.

MOVEMENT COMPENSATION / FLANGE VERSIONS

DN	Δ lat Lateral movement ± mm	Permissible vacuum w/o supporting ring at length BL bar absolute	Weight approx. kg
25	15	-	4.5
32	15	0.6	5.1
40	15	0.6	5.6
50	15	0.6	6.3
65	15	0.7	7.7
80	15	0.65	10.5
100	15	0.6	12.5
125	15	0.75	16.5
150	15	0.65	19.2
200	15	0.7	22.0
250	15	0.7	26.8
300	15	0.8	32.3

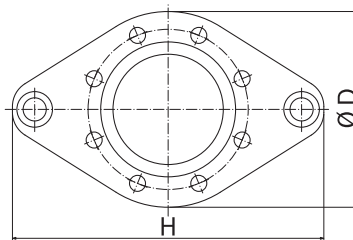

DN 25 - DN 150

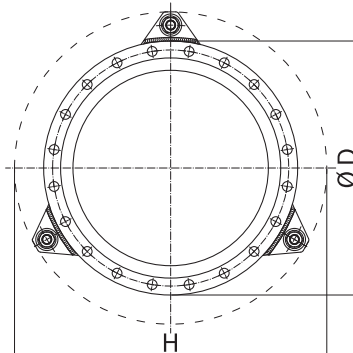

DN 200 - DN 300

Number of tie rods depending on pressure

ACCESSORIES

- Vacuum supporting ring
- Internal guide sleeve
- Flame-proof protective cover
- Protective hood
- Protective tube

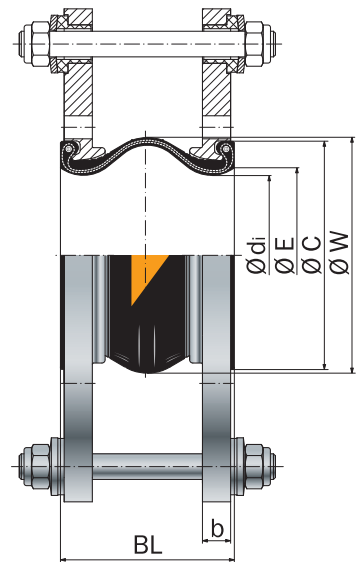

DN 25 - DN 150

Type R-2

Tie rods, external restraints, carried on silencing rubber sockets

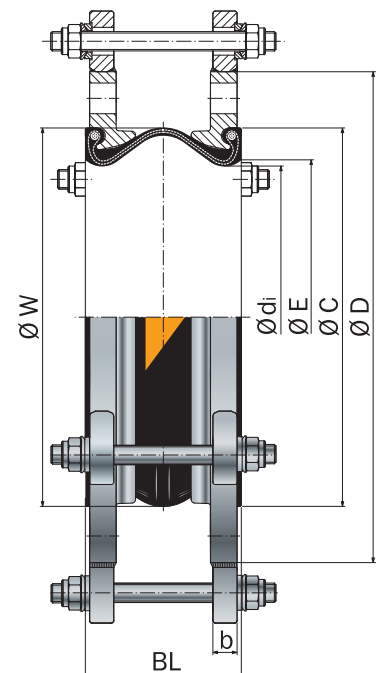

DN 200 - DN 300

Type R-2

Tie rods, external restraints, carried on spherical washers and conical seats